

Research on Influences of Modifications of Small Burner upon Fire Behavior of Building Materials and Their Fire Classification

Du Lanping, Tianjin Fire Research Institute, China

Abstract

In this paper we have researched the effect of various modifications of the small burner on the flame picture, the fire behaviour of different materials and their fire classification. The result shows that all the modifications may cause influences upon the flame picture and the behaviour of the materials under test. The structure of the stabilizer (with or without an aperture mask) and the diameter of gas nozzle as well as the flaming duration (15s/30s) are important influence factors.

1. Introduction

Various modifications of the small burner as well as the application of different gases are discussed within the range of the international standardisation and harmonization. The primary goal of this paper is to research the influence of individual variations of the small burner on the flame picture and the fire behaviour of different materials and their classification.

2. Modifications of the Small Burner

The small burner is used for testing the fire behavior of materials so as to produce a flame with a given length and a constant temperature profile and to simulate thereby an outside ignition source. The development of the small burner has a long history. It began thirty years ago when the match was first used as ignition source. The small burner operated with gas have been commonly used now. The first small burner was developed in Germany in 1960s, and was standardized (DIN 50051[1]) in 1971. In recent years this small burner has also been adopted by other countries and organizations or quoted in their draft standards but with various modifications shown in Table 1.

Table 1. Modifications of small Burner

Standard/ Document	Burn gas	Stabilisator With / Without aperture mask	Diameter of gas nozzle (mm)	Determining method	Flame length (mm)	Flaming duration (s)	Inclination angle
DIN 50051	Propane	Without	0.17+0.03/0	Visual	20	15	45
Onorm B3800	Propane	Without	0.17+0.03/0	Visual	20	15	45
SN 198898	Propane	Without	0.17	Cotton thread	40+/-3	3/15	30
UNI 8457	Propane	Without	0.17+/-0.01	Cotton thread	21+/-1	30	45
UNI 8456	Propane	Without	0.17+/-0.01	Visual	40	12	45
ESSAI DE PROPAGATION DE FLAMME	Propane	With	0.18+0.03/0	Visual	20	15	45
CEN/TC (EG) prEN 156	127Propane	Without	0.17+0.03/0	Cotton thread	20	15	45
COM (92) 201 final- SYN 417	Propane /Butane	With	0.18+0.03/0	Cotton thread	40+/-2	5/15	30
ISO/TC92/SC1 N173B	Propane		0.17+0.03/0	Cotton thread	20	15	45
ISO 6940	Propane /Butane	With	0.18+0.03/0	Visual	40+/-2	up to 20	30
ISO/DIS 6941	Propane/Butane	With	0.18+0.03/0	Cotton thread	40+/-2	5/15	30
ISO/DIS 10093.2	Propane/Butane/ Methane	With	0.18(+0.03/0)	--	20	--	

3. Test Procedure

In order to research the influences caused by the various modifications of small burner upon the flame picture of the burner and the temperature distribution on the surface of the specimen as well as the fire behaviour of the materials under test and their fire classification, a series of tests was carried out. For each test, only one parameter was changed against the burner according to DIN 50051.

The test arrangements were as follows:

A. Burner, operated with propane, with a stabilizer without an aperture mask and with a gas nozzle of 0.18 mm in diameter.

Symbol (for example): I P Wo / 0.18

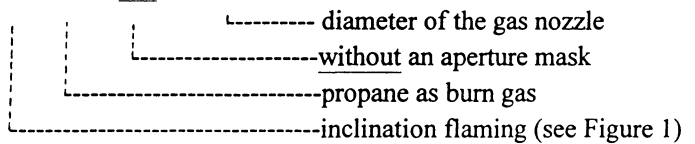

B. Burner, operated with butane, with a stabilizer without an aperture mask and with gas nozzle of 0.18 mm in diameter.

Symbol: IBWo/0.18

C. Burner, operated with methane, with a stabilizer without an aperture mask and with a gas nozzle of 0.18 mm in diameter.

Symbol: IMWo/0.18

D. Burner, operated with propane, with a stabilizer with an aperture mask (see Figure 2) and with a gas nozzle of 0.18 mm in diameter.

Symbol: IPWi / 0.18

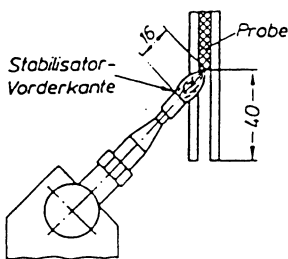

Figure 1. Inclination flaming

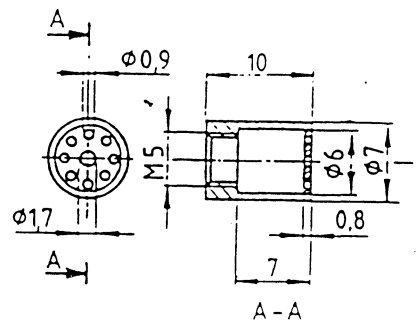

Figure 2. Stabilizer with an aperture mask

E. Burner, provided with propane, with a stabilizer without an aperture mask and with a gas nozzle of 0.31 mm in diameter.

Symbol: IPWo/0.31

For test E, a gas nozzle was selected, its diameter was 0.31 mm so as to indicate the tendency: How did this factor take effect upon both the flame picture and the fire behaviour of the materials.

F. This test was concerned with the influence of the flaming duration. Comparison-tests were carried out with two different flaming duration, namely 15s (DIN 4102 part 1 [2]) and 30s (UNI 8457 [10]).

G. Two tests were carried out in test G so as to research how great the influence of the determination methods (visual observation of the reaching to the graduation mark or overburning the cotton threads, see Figure 3) on the time expended for reaching the graduation mark is.

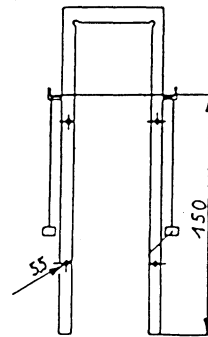

Figure 3. Determination method with cotton threads

4. Test Materials

Two kinds of materials were tested in this work:

Wood (density: 512.8 kg/m^3)

Polyurethane hard foam (density: 41.1 kg/m^3)

5. Test Method

5.1 Thermograph

The technique of the thermograph was used for determining the temperature distribution. Therefore the temperature distribution on the surface of a body can completely be shown.

In order to observe the differences between the flame pictures under different arrangements of the burner, at first the flame picture without contact with the specimen was researched thermographically. Here the burner was vertically placed, and a flame of 20 mm long was adjusted with a gauge .

5.2 Temperature Measurement

In order to research the quantitative effects related to modifications of the burner, the temperature on the axis of the flame and on the surface of the specimen were measured with sheath thermoelements (0.55 mm chromel-alumel). A calcium silicate plate was placed on the position of the specimen.

During measuring the temperature on the axis of the flame, the burner was vertically placed, and a flame of 20 mm long adjusted. The thermoelement was installed over the burner opening in different heights on a tripod. Here we supposed the burner opening to be the height “0” (see Figure 4).

During the measuring of temperature distribution on the surface of the specimen, the burner was placed at 45° according to DIN 4102 Part 1 [2] .

5.3 Material Test

Wood and polyurethane hard foam, PUR were tested in the test boxes according to DIN 4102 Part 1 with the different modifications of the burner under inclinating flaming. An additional graduation mark was made at 50 mm over the bottom of the specimen, shown as M1 in Figure 5.

Height (mm)

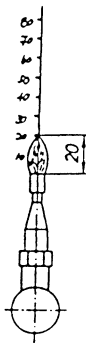

Figure 4. Measurement positions of the temperature on the axis of the flame

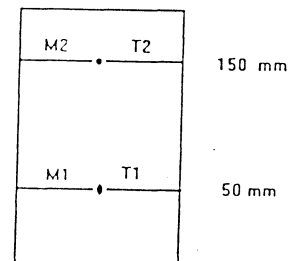

Figure 5. Graduation mark

Besides the time expended for reaching to the graduation mark, which can be used for determining the classification (B2/B3) of the building material, for the wood specimen, the speed, with which the flame peak went from a graduation mark to another, was also determined and used as a yardstick for valuation the influence of individual modification of the small burner.

The fire spreading speed (FSS) is determinable from the times, at which the flame peak reached the two measurement marks M1 and M2 as:

$$FSS=(150-50)/(T2-T1)$$

For the research of the influence of the determination method, two parallel measurements were carried out on one specimen by two people, i.e., for each specimen, not only visually the time to the reaching the graduation mark but also the time to the overburning of the cotton threads were determined.

6. Results of the Measurement and Test

6.1 Thermogram of the Flame

The thermograms that show the temperature distribution of the flame and the temperature curves in different heights over the burner opening are given in figure 6 . These expressions indicate only the relative temperatures and show tendentially the influence of the individual modifications of the burner.

In comparing with propane and butane as burn gas, the flame of burner with methane has a lower temperature. This is not unexpected since a flame of 20 mm long can not be stabilised, when the DIN burner is operated with methane and adjusted with the existing pressure regulation equipment. The flame length is only 15 mm.

A reduction of the flame temperature is shown by using a gas nozzle with a bigger diameter (0.31 mm).

6.2 Temperature Distribution

6.2.1 Temperature on the Axis of the Flame

The measurement of temperature distributions (TA) on the axis of the flame under different conditions shows that

- The highest temperature lies on the peak of the internal cone;
- The flame temperatures are influenced by various modifications of the burner.

The temperatures on the peak of the internal cone of the flame in different modifications of the burner give following sequence:

$$T_a (IPW_o/0.18) > T_a (IPW_i/0.18) > T_a (IPW_o/0.31) > T_a (IBW_o/0.18) > T_a (IMW_o/0.18)$$

6.2.2 Temperatures on the Surface of the Calcium Silicate Plate

The temperature distributions were influenced by the variations of the small burner and give the classification arrangement as followings:

$$T_f (IPW_o/0.18) > T_f (IBW_o/0.18) > T_f (IPW_i/0.18) > T_f (IPW_o/0.31) > T_f (IMW_o/0.18)$$

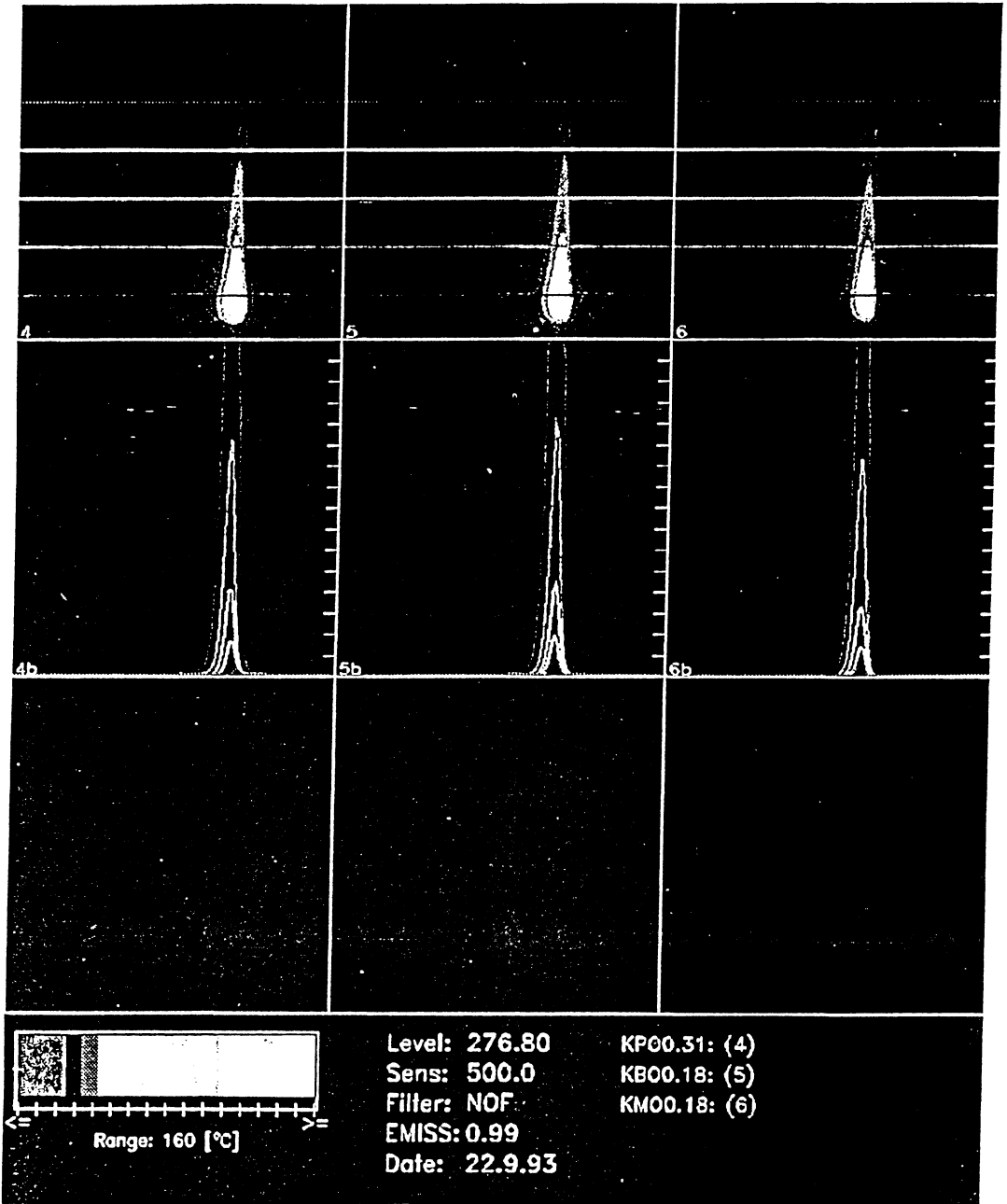

Figure 6. Thermograms of the flame
 (4--IPWo/0.31, 5--IBWo 0.18, 6--IMWo/0.18)

6.3 Material Test

Wood plate with thickness of 2 mm and polyurethane hard foam plate with thickness of 50 mm were tested. The results were compared with the result of the DIN burner (IPWo/0.18).

6.3.1 Influence of the Different Burn Gases (Relation IPWo/0.18 and IBWo/0.18)

Table 2 shows the comparison of the time to the graduation mark and the flame spread speed between butane and propane as burn gas. It can be seen that the flame spread on the specimen with butane is slower than with propane.

Table 2. Influence of the different burn gases

IPWo/ 0.18		IBWo/ 0.18	
FSS (mm/s)	TIME (s)	FSS (mm/s)	TIME (s)
AV: 6.76+/-0.49	AV: 27.20+/-2.77	AV: 6.32+/-1.26	AV: 28.60+/-3.57

Note: FSS: Flame Spread Speed

TIME: Duration until the reach to the graduation mark (150 mm over the specimen bottom)

AV: Average Value

6.3.2 Influence of the Different Burn Gases (Relation IPWo/0.18 and IMWo/0.18)

When methane is used as burn gas and other parameters maintain constant, the time to the graduation mark is as follows:

Time (propane): time (methane)=27.2: 28.9s (for wood)

Time (propane): time (methane)=5.26: 6.02s (for PUR)

6.3.3 Influence of the Aperture Mask (Relation IPWo/0.18 and IPWi/0.18) For wood, when the aperture mask is used, the flame spread speed is slower than without it (propane as burn gas) (Table 3). For PUR, the difference is not significant (propane as burn gas). A statistical study with T-test can obtain the same result .

Table 3. Influence of the aperture mask

IPWo /0.18		IPWi /0.18	
FSS (mm/s)	TIME (s)	FSS (mm/s)	TIME (s)
AV: 6.76+/-0.49	AV: 27.20+/-2.77	AV: 5.80+/-0.69	AV: 29.4+/-2.01

6.3.4 Influence of the nozzle diameter (Relation IPWo/0.18 and IPWo/0.31)

For wood, Table 4 shows the average spread speed in different diameter of the nozzles. A remarkable reduction of the flame spread speed is shown by increasing the nozzle diameter. Based on the T-test, the difference is significant. For PUR, the measured times are not remarkably different.

Table 4. Influence of the nozzle diameter

IPWo /0.18		IPWo /0.31	
FSS (mm/s)	TIME (s)	FSS (mm/s)	TIME (s)
AV: 6.76+/-0.49	AV: 27.20+/-2.77	AV: 4.73+/-0.34	AV: 33.5+/-1.77

In some further tests on wood, this tendency could be verified by using a burner of 0.205 mm in diameter of nozzle. Especially, when an aperture mask is used, the difference of the results between the diameters of 0.18 mm and 0.205 mm are very marked.

6.3.5 Determination Method by Visual Observation or Cotton Threads

The two materials measurements show that the determination method has an influence on the test results. By using the cotton threads the time until reaching the graduation mark is tendentiously longer than visual . For PUR, this difference is not significant, while for wood a remarkable difference can be seen. The reason is that the flame of the wood is not closely to the surface of the specimen (see Figure 7). Thus for this kind of material the overburning of the cotton thread is later than the visual observing of the reaching to the graduation mark.

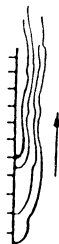

Figure 7. Flame on the surface of wood

6.3.6 Flaming Duration

For PUR, the prolonging of the flaming duration does not play any role, because the graduation mark already has been reached after 6s, i.e., the test has already been ended. For wood, its' effect is meaningful (Table 5). The flame spread speed becomes much faster with the prolonging of the flaming duration. The statistical result shows that there is a remarkable difference of the flame spread speed between the two flaming duration.

Table 5. Influence of flaming duation

IPWo /0.18 (15s)		IPWo /0.18 (30s)	
FSS (mm/s)	TIME (s)	FSS (mm/s)	TIME (s)
AV: 7.46+/-0.56	AV: 25.36+/-0.52	AV: 8.33+/-0.85	AV: 23.38+/-1.42

7. Discussion

The test results show that all the modifications, shown in Table 1, have influence upon the flame picture, the fire behaviour of the material under test as well as their classification. The diameter of gas nozzle, the type of stabilizer (with or without an aperture mask) and the flaming duration are decisive factors.

The diameter of gas nozzle plays an important role for the characteristic of the flame. A marked drop of the flame temperature and the spread speed of flame peak can be caused by using a gas nozzle with a quite bigger diameter. With a slow flow of the burn gas, the flame becomes “soft” and therefore is susceptible to be disturbed by the exhaust flow.

The prolonging of the flaming duration is also of influence. It results in higher temperature on the surface of the specimen. For some kinds of materials, this influence acts also on their fire classification. When the flaming time becomes longer, an enlargement of the length of the specimen should be considered.

A stabilizer with an aperture mask can better stabilize a flame on the burner, but it products more heat than the stabilizer without an aperture mask. In the test carried out here, lower flame temperatures within 50 mm over the bottom of the specimen were observed by installing the aperture mask.

The temperature on the axis of the flame with butane as burn gas is lower than it with propane.

8. Summary

By the adopting of the small burner, which was first developed and standardized in Germany, in other standards some modifications were made .

The picture of the flame itself and the flame on the surface of the materials under test were researched thermographically and by temperature measurement. Two typical materials were tested (DIN 4102 Part 1) with the burner (DIN 50051) under taking into account of different variations of the small burner.

The results of the research and test indicate that all the modifications of the small burner may cause some influence upon the flame picture and the behaviour of the materials under test. As for the flame temperature, the time required for reaching the graduation mark and the spread speed of the flame peak, the structure of the stabilizer (with or without an aperture mask) and the diameter of gas nozzle as well as the flaming duration (15s/30s) are important influence factors.

The research results show that:

1) The flame can better be fixed on the stabilizer with the aperture mask. In this case the time required for reaching the graduation mark is longer and the flame spread speed is lower.

2) An excessive big nozzle in diameter is unsuitable.

3) With other kinds of burn gases than propane, the required flame is difficult to be realized, and an aperture mask should be used when butane is used as burn gas.

The influence on the material's classification of the phenomena determined by 1) and 2) should be further reviewed.

Acknowledgements

This work was supported by Prof. Wolfram Becker, Dipl.-Ing. Klaus Hofmann and Dipl.-Phys. Edith Antonatus from BASF AG, Aweta Brandschutztechnik, Germany.

References

1. DIN 50051 Prüfung von Werkstoffen/Brennverhalten von Werkstoffen/Brenner
2. DIN 4102 Teil 1 Brandverhalten von Baustoffen und Bauteilen;
3. ISO 6940 Textile fabrics. Burning behaviour-ease of ignitiovertically oriented specimens
4. ISO 6941 Textile fabrics. Burning behaviour-measurement of flame spread properties of vertically oriented specimens
5. ISO/DIS 10 093.2 Plastics-Fire tests-Standard ignition sources
6. COM(92)201 final- SYN 417 Proposal for a Council Directive on the approximation of laws of the Member States relating to the burning behaviour of materials used in the interior construction of certain categories of motor vehicle (18. Mai 1992)
7. SN 198898 (Schweiz) Bestimmung des Brenn-und Glimmverhaltens textiler Flachengebilde, Kantenzündung vertikal
8. ONORM B 3800 Baustoffe: Anforderungen und prufungen
9. UNI 8456 Reazione al fuoco mediante applicazione di una piccola fiamma
10. UNI 8457 Reazione al fuoco mediante applicazione di una piccola fiamma
11. ISO/TC92SC1 N173B Ignitability of building products under direct flame impingement
12. CEN/TC127(EG) Test for ignitability of building products