

# Development of Fire-Resistant Screens for Large Spaces

**K MURAOKA, M HONMA and Y MIYAGAWA**

Technical Research Institute

Obayashi Corporation

2-40, Shimokiyoto 4-chome, Kiyose-shi, Tokyo 204, Japan

## ABSTRACT

In Japan, metal fire shutters are used in all kinds of buildings as fire partition. However, in large spaces with high ceilings and long spans, it has been impossible to use metal fire shutters because of the size of their housings and their heavy weight. A system of fire-resistant screens that can be used to form fire partitions has been developed to meet this need. The performance of this system is equal to that of conventional metal fire shutters. This paper describes experiments and simulations which confirm the system's fire resistance and motional performance. It also describes how this system is applied to a multipurpose gymnasium.

## INTRODUCTION

It has been impossible to compartmentalize a large space with metal fire shutters or metal fire doors in case of fire up to now because of the size of their housings and their heavy weight. Therefore, alternative measures were taken, such as the use of big water guns, to extinguish fires at an early stage or small areas within a large space to contain smoke and fire. Now, we have developed a fire-resistant screen system, to solve such problems. This system can prevent fire from spreading in a large space, and also enables an open plan without the need for guide studs for fire shutters. This paper outlines this fire-resistant screen system, its fire resistance, and its motional performance. It also introduces an example of a multipurpose gymnasium in which the system was first realized.

## OUTLINE OF FIRE-RESISTANT SCREEN SYSTEM

### Screen System Specifications

In this system, the fire-resistant screen is formed with several screens (screen units) aligned horizontally (see Figure 1). The side edges portions of the respective screens overlap each other by 500 mm. The screens at each end descend along guide rails (depth 200 mm, width 30 mm). The width of each unit depends on the maximum permissible deflection of a rolling shaft (a width of about 8 m is normally used). Each screen droops from a roll-up device housed within a storage box arranged on the ceiling of the building.

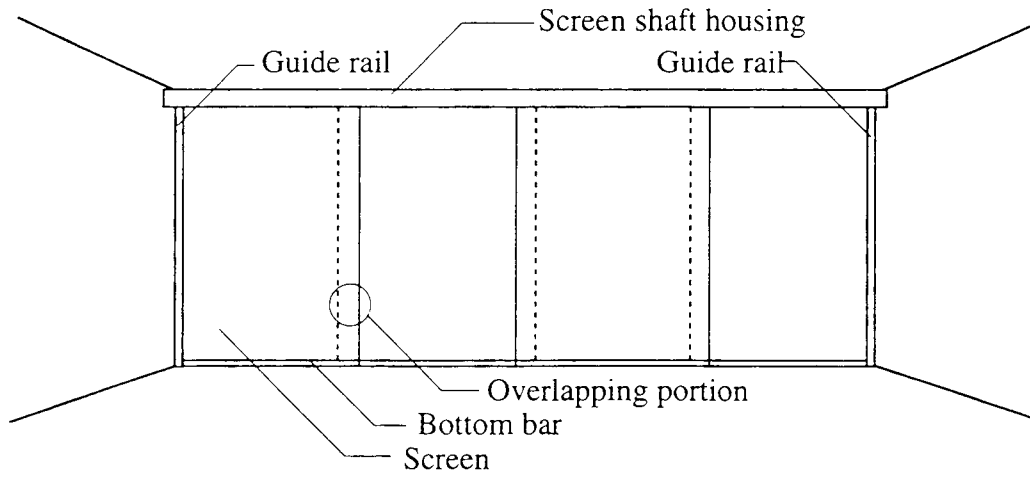

Figure 1 View of Screen Arrangement

As shown in Figure 2, independent roll-up devices are provided for each screen unit for rolling-up each individual screen independently of the others. Adjacent roll-up devices are arranged offsetting toward the left and right sides relative to a vertical plane, along which the screens droop. Since the roll-up devices are alternately arranged at either sides of the vertical plane, the roll-up direction of the screens alternates depending on the side to be placed so that all of the screens droop along the same vertical plane. With this arrangement, even when the screens are arranged with overlapping side edges, the roll-up devices for adjacent screens do not interfere with each other.

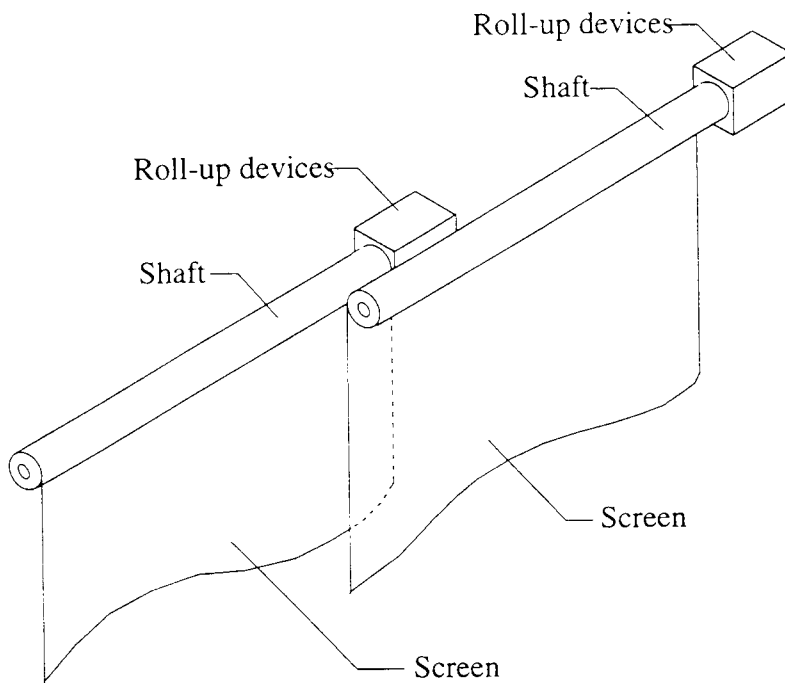

Figure 2 Enlarged View of Screen Arrangement

As shown in Figure 3, independent bottom bars (metal bars) are horizontally fixed on the lower ends of of respective screens. The weight of the bottom bar applies an appropriate tension force on each of the screens so that the screens combine to form a smooth plane and do not flutter in the wind or the like. Furthermore, at the overlapping portion between adjacent screens such as A and B, the bottom bar of screen A is partly cut-out on the front side (referred to as cut-out portion "a"), while the bottom bar of screen B is partly cut-out on the back side (referred to as cut-out portion "b"). The cut-out portions a and b are complementary so that they form a single bar when combined. With this arrangement, screens A and B form a tightly-knit arrangement.

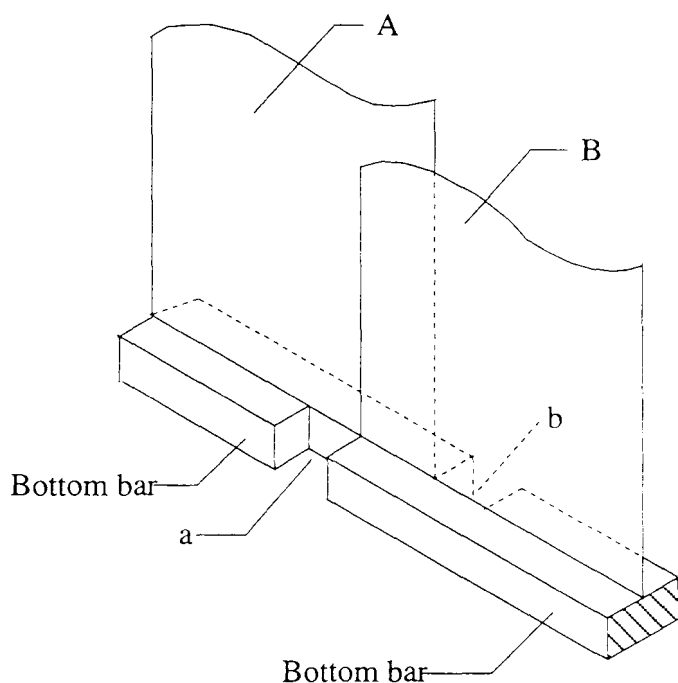

Figure 3 Enlarged View of Screen Arrangement

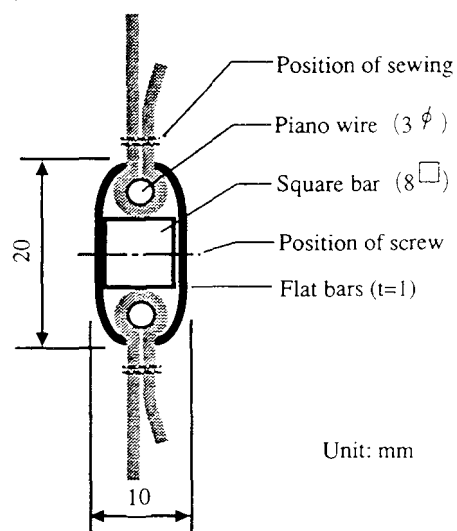

Figure 4 Section of a Metal Joint

In case of normal use such periodical checks, the shaft of each roll-up device is driven by an electric motor, but in case of fire, each screen descends under its own weight (the weight of the bottom bar). It stops descending momentarily at 500~600 mm above floor level so that people trying to escape are not trapped or crushed by it. The controls of the fire-resistant screens are connected to both the fire alarm system and a remote control system; accordingly, they automatically roll down when the alarm goes off or a control switch in the main control room is turned on. The fire-resistant screens are made of a silica cloth manufactured in 1,000 mm-wide rolls, which must be joined together to cover a large area. This system can use either a sewn joint or one using metal flat-bars (see Figure 4).

## Merits of Fire-resistant Screens

Table 1 compares the problems of conventional metal fire shutters with the benefits of fire-resistant screens. This system of plural screens can be used whatever widths are needed, without studs, and has many advantages including light weight and compact rolling shaft housings. Furthermore, in the case of forming one or more slits extending from an intermediate height between the ceiling and the floor at appropriate positions for providing a refuge path (walk-through type), it is not necessary to provide a fire door in the vicinity of the screens. When fire shutters descend in case of fire, those near the shutters risk being enclosed by them within the burning building. In contrast, this walk-through type screen system helps reduce such panic.

Table 1 Comparison of Metal Fire Shutter and Fire Resistant Screen

Metal Fire Shutter	Fire Resistant Screen
Guide studs are needed within 5~8 m in width*	Guide studs are not needed
Heavy	Light
Door for passing through is needed beside the shutter	Door is not needed beside the screen (In case the walk-through type screen[1] is installed)
Shaft housing is large	Shaft housing is small
Possibility of panic when it descends	Reduces panic

\*to comply with the building regulations in Japan

## FIRE RESISTANCE TEST

### Test Methods and Specimens

Under Japanese regulations, fire shutters and fire doors are required to resist fire for one hour. To confirm the one hour fire endurance of a fire-resistant screen system, fire resistance tests were conducted using a gas furnace. We used a multi-purpose furnace to test a wall type specimen 1,500 mm wide and 1,800 mm high. A fire-resistant screen specimen has an overlapping part and a joint comprising metal pieces. A total of 15 thermocouples (Chromel/Alumel, 0.8 mm diam.) were installed on the surfaces of the screens: 9 points in the furnace and 6 points out of the furnace. The locations are shown in Figure 5. A specimen was heated for one hour in accordance with the standard heating temperature-time curve prescribed by JIS A-1304. Temperatures in the furnace and temperatures on the surface of a specimen were then measured at 30-second intervals.

The measurement was continued until one hour after heating ended. Figure 6 is a photograph from this fire resistance test.

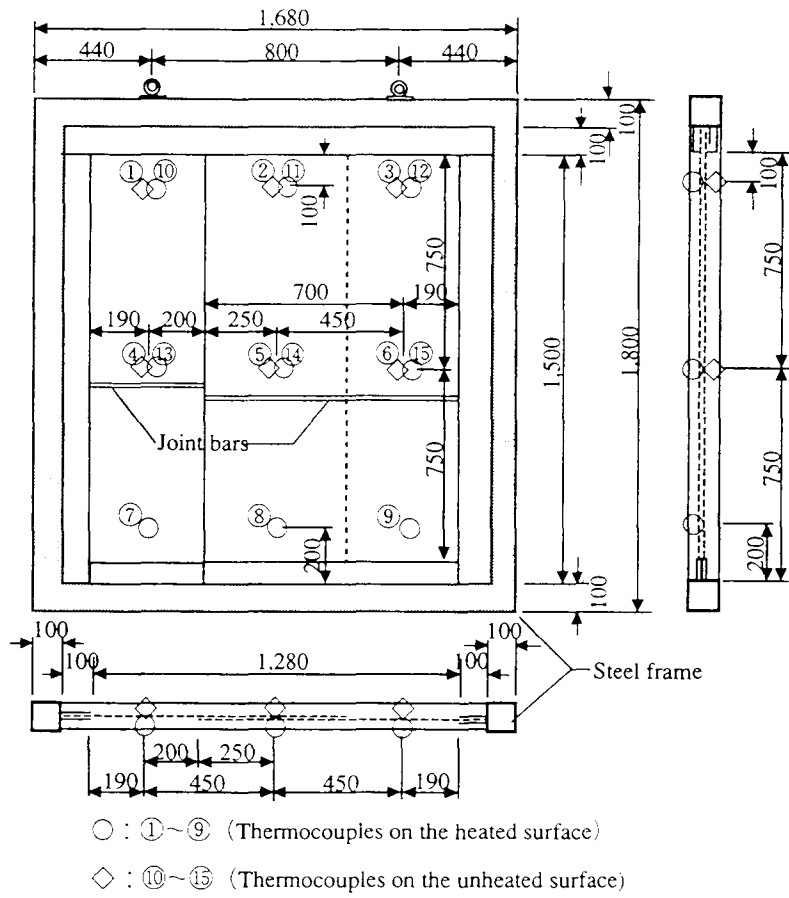

Figure 5 Specimen and Thermocouples (Unit: mm)

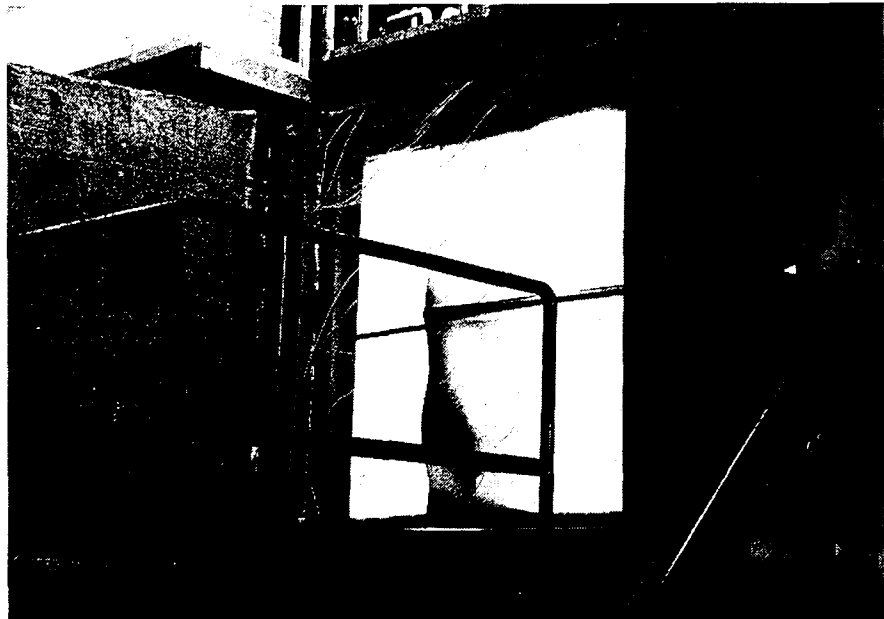

Figure 6 Fire Resistant Test

## Test Results and Considerations

The following findings were obtained from the fire resistant.

- 1) While the surface temperature of the specimen's heated side rises to 950°C, its unheated side remains at 500°C (See Figure 7).
- 2) No blowing of flames to the unheated side was observed during heating.
- 3) Deflections of metal joint flat-bars were observed.
- 4) Vertical contraction of silica cloth was observed, causing spacing of 1 cm between the bottom bars of the screen and the outer flame of the specimen.
- 5) Smoke was emitted momentarily just after heating began, and continued for one minute.

As mentioned above, slight deflections and contractions were observed on the specimen, but no blowing of flames to the unheated side was observed. Problem 4) can be solved by slackening the screen when the bottom bar is put onto the floor, thus absorbing contractions and closing the space between the bottom bars and the floor. If we can solve this space problem, this system of fire-resistant screens can pass a fire-door equivalency examination in Japan. The momentary smoke emission just after the beginning of the heating is due to smoldering of a small quantity of binder (fire retarded acrylics 1% in content) resins in the silica cloth.

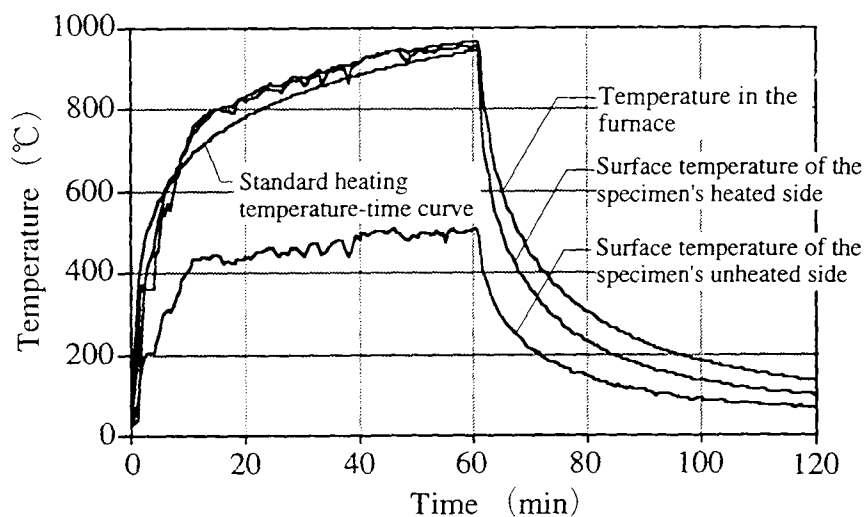

Figure 7 Time-Temperature Curve During Fire Resistance Test

### Considerations of Temperature of Unheated Side

The surface temperature of the specimen was measured by thermocouples in the last section. In this method, accurate temperatures may not have been obtained because, strictly speaking, the thermocouple measurement points merely indicate the temperature near the surface of the

specimen. For this reason, fire resistant tests were conducted again to measure accurately the temperature of the unheated side of the specimen. Two kinds of measurement, measurement by thermocouple and by thermal infra-red images, were conducted. In the measurement by thermocouple, the metal junctions contacted the surface of the screen and was covered by aluminum foil. In the measurement by thermal images, because the emissivity of silica cloth was unknown, black paint was painted on the unheated surface of the screen, and the temperature at that point was measured at emissivity  $\epsilon = 0.95$ . The change of temperature in the furnace and the temperature on the surface of the specimen, measured by these two methods, is shown in figure 8. The reason for the decrease of temperature of the unheated side measured by the thermocouple after heating for 25 minutes is peeling of the aluminum foil. The temperature of the unheated side measured by a thermocouple after peeling of the aluminum foil was not more than 85.5% on average of that measured by thermal images. If this temperature measured by thermal images is correct, then the temperature on the surface of the specimen is not more than 68% of the heated side on average. Therefore, the unheated side temperature of 500°C, described in the last section, must be corrected to 621°C.

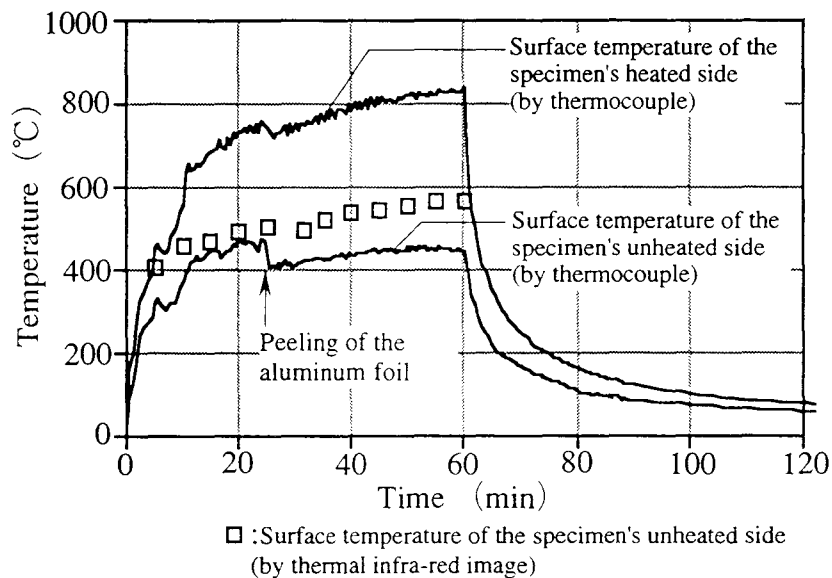

Figure 8 Time-Temperature Curve During Fire Resistance Test

## MOTIONAL PERFORMANCE TEST

### Test Specimen

To confirm the motional performance of this fire-resistant screen system, a real-scale test specimen (including 500 mm-wide overlapping part) was set up, and motional performance tests were conducted. Taking into account site restrictions on setting up, screen height (height of opening) was 7.5 m, and screen widths were 4.5 m and 2 m (see Figure 9).

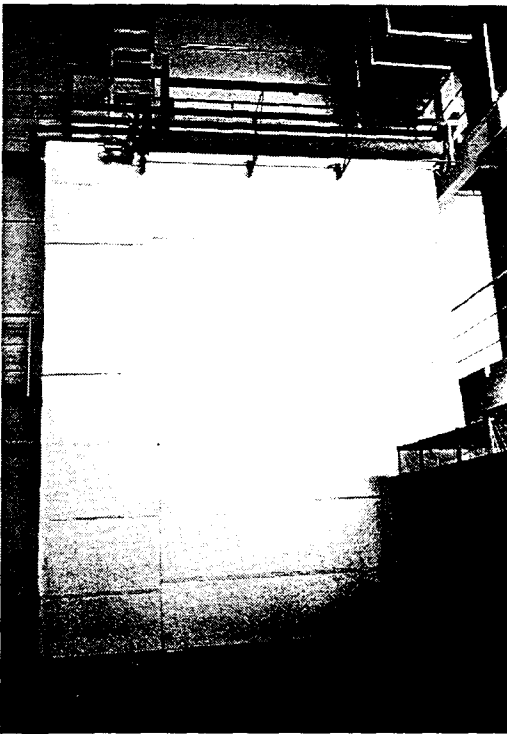

Figure 9 Overview of a Specimen  
for Motional Test

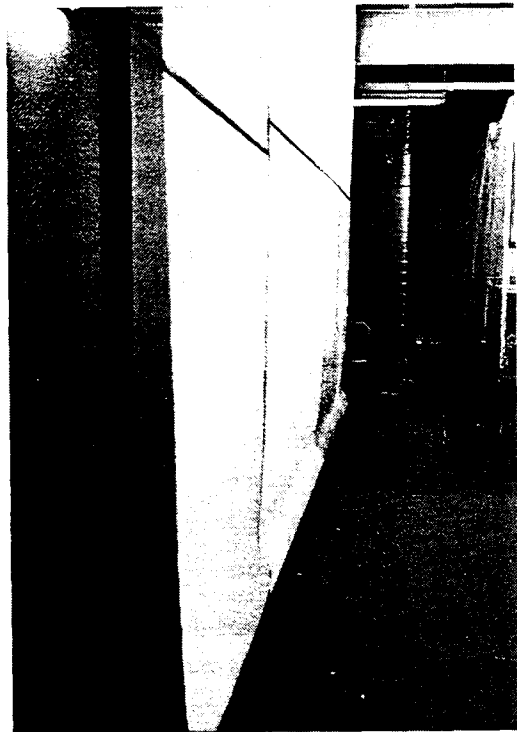

Figure 10 Overlapping Part of Screens

## Test Results

Performances was confirmed by several motional tests as follows.

- 1)Both while descending and while rolling up by electric power and while descending by gravity, smooth motion was confirmed.
- 2)No rolling slip was observed during repeated descending and rolling up tests.
- 3)Clearance of the overlapping part was about 1cm (see Figure 10).
- 4)The stopping position of the bottom bars can be adjusted to any position, and slackening of the screens when the bottom bars touch the floor can be adjusted. Actually, it is necessary to slacken the screen to take into account the contraction of the screens caused by real fire heating. No increase in clearance was observed with slackening of the screen.

## APPLICATION TO A REAL BUILDING

### Outline of Applied Building

The applied building is a multipurpose gymnasium whose main uses are as a gymnasium and as a concert hall. The gymnasium forms a big box structure 17 m high, 56 m wide, 148 m long. We would normally plan to partition this structure into a concert hall and a gymnasium by a smoke and fire shutter at the start. With this plan, it would be necessary to build a ceiling and



some guide-studs adjacent to the concert hall. Thus it would be impossible to make a partition, using fire and smoke shutters (metal shutters) with such a high ceiling and long span, and this plan mars the open design of the concert hall. Therefore, we planned to partition it by simply using a fire-resistant screen system which forms a fire wall from the structure of the roof to the floor. Thus, both improved safety in evacuation because of ups in perspective and an open-design concert hall can be realized. Figure 11 shows the elevation of this fire-resistant screen system, and Figure 12 shows the section of the housing of the screen shaft. The fire wall, which separates the two parts for different uses, needs a fire door with equivalent performance as regulated by the Building Standards Law in Japan. In addition, a change in position of the fire wall can cause an increase in the fire area, so that it does not comply with the building regulations in Japan. Therefore, we obtained the approval of the Minister of Construction based on Article 38 of the Building Standards Law when we made our application for fire-resistant screens in this building.

### Study on Pressure Difference

A space in which the fire-resistant screen system is installed may have many doors facing outside space. When these doors are opened in case of fire, the pressure difference before and behind the screens increases because of wind blowing into the inner space and increasing the fire room's temperature. This may cause the screen to open. Accordingly, it is necessary to determine the pressure difference before and behind the screens when a fire is spreading and wind is blowing outside the building, using a smoke flow simulation of a two-layer-zone model [2]. Figure 13 shows a model and calculation conditions. The opening time of doors on the escape route complies with results of an evacuation simulation on this building. The direction and speed of wind with a recurrence period of fifty-years are used. These parameters are derived from wind data taken by the Automated Meteorological Data Acquisition System (AMeDAS) of the Japan Meteorological Agency.

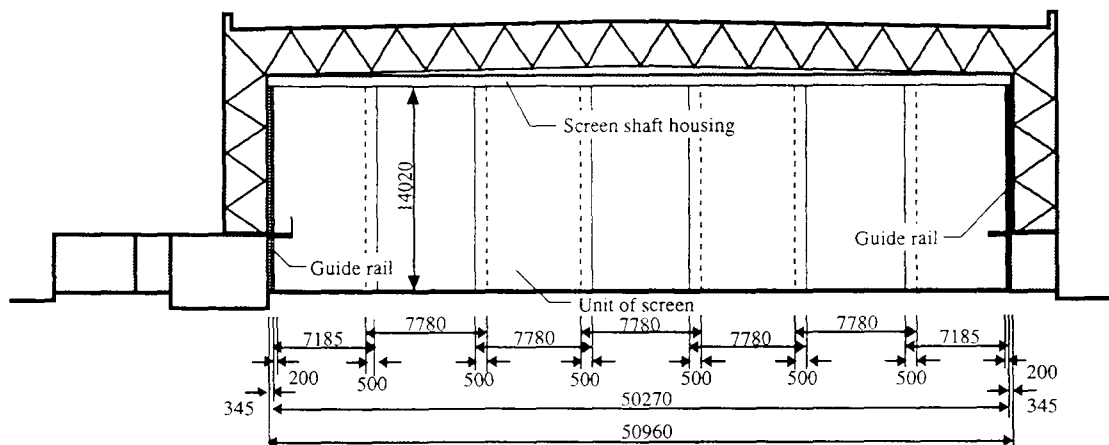

Figure 11 Elevation of Fire Resistant Screen Systems (Unit: mm)

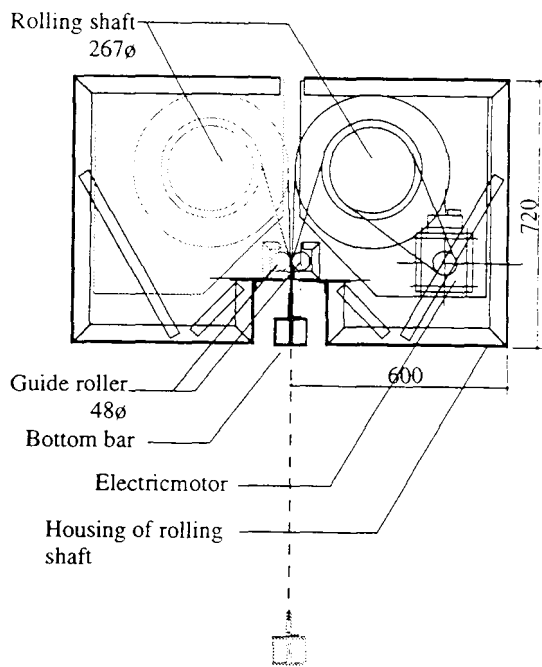

Figure 12 Section of Screen Shaft  
Housing (Unit: mm)

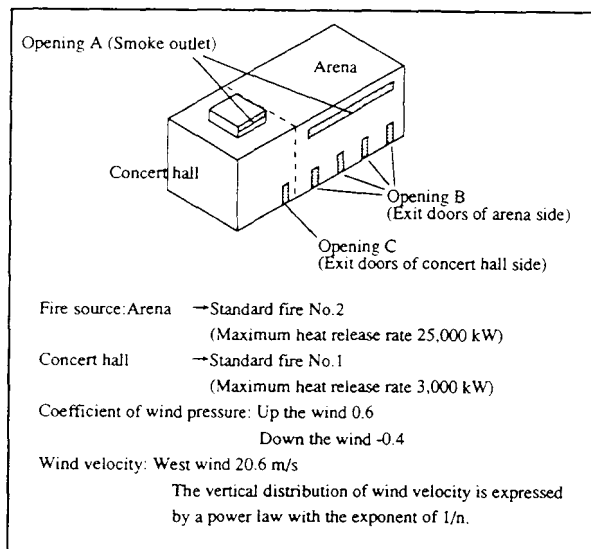

Figure 13 Simulation Conditions

### Simulation Results

Figure 14 shows the variation with time of the pressure difference before and behind the screens and Figure 15 shows the distribution of pressure difference from the bottom to the top of the screens when the pressure difference peaks out. The pressure difference increases steeply when doors to outside of the un-burning room (concert hall side) are opened, and it rises to the peak after 320 sec when the heat release rate of the fire rises to its maximum value. The pressure difference reaches its maximum value of 12.4 Pa at the top of the screens at this time. The average pressure difference from the bottom to the top of the screens at this time is 6.8 Pa. Thus, we set the weight of the bottom bars at 10 kg/m to prevent the screens from opening due to this pressure difference.

### Installation of the System

All the components of the system are manufactured in the factory. It is difficult to remove stains from screens made of Silica-cloth because the Silica-cloth is not coated with anything. Therefore, each screen was carefully rolled around the shaft in the factory, and then brought onto the construction site. The order of installation on the construction site is as follows.

- 1) Weld brackets (with bearings) to support beams.
- 2) Mount shafts (with screens) , electric motors and drives on brackets
- 3) Install Bottom bars on the ends of each screen and mount guide rollers.
- 4) Set up guide rails on the side wall.

5) Encase the rolling up system in steel plates

After installation, smooth motion of this screen system was confirmed. Figure 16 shows an overview of the installed fire-resistant screen system.

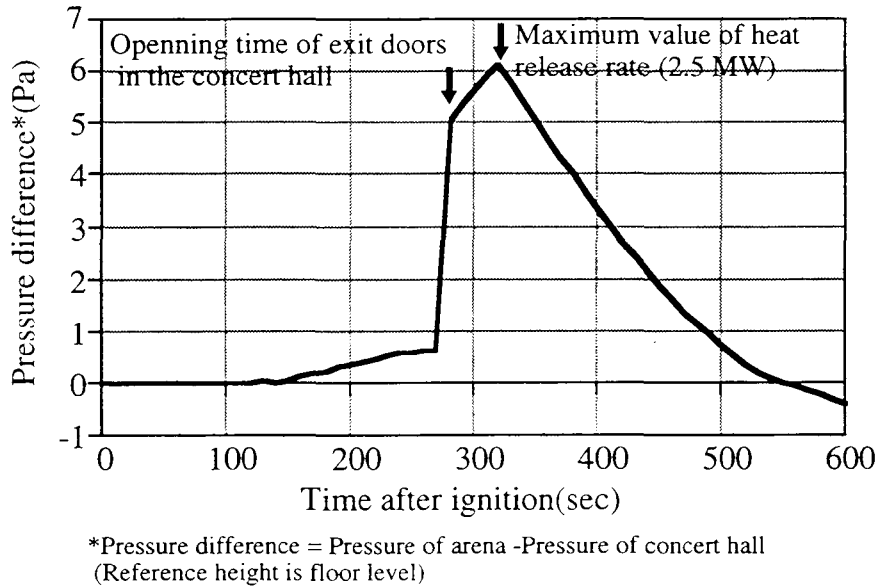

Figure 14 Pressure Difference Variation with Time

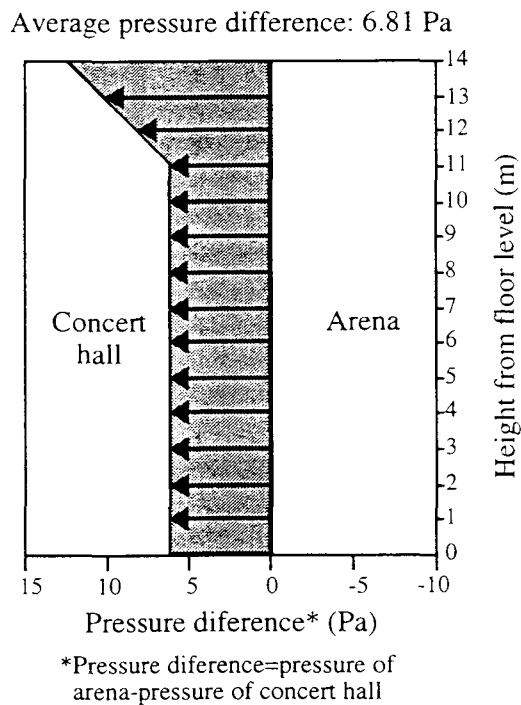

Figure 15 Vertical Distribution of Pressure Difference

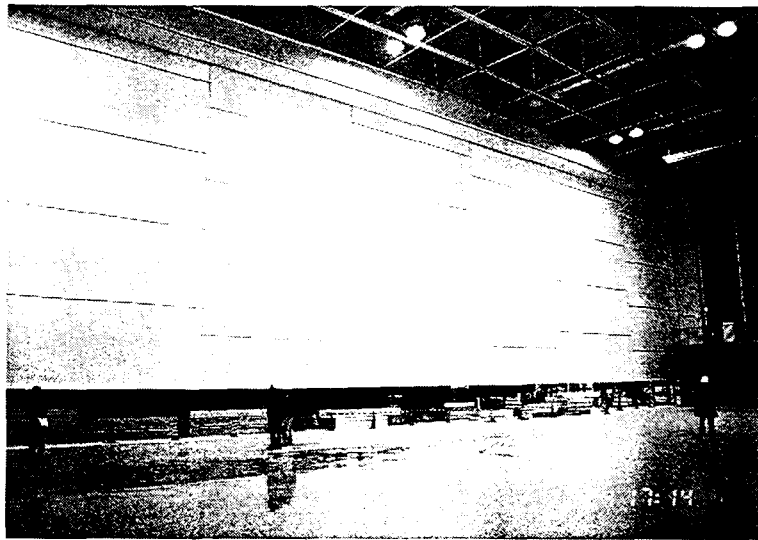

Figure 16 Overview of Fire-resistant Screen System

## CONCLUSIONS

Experiments and simulations were performed to determine fire resistance, motional performance and stability when the screens were shut down. They were a part of a set of experiments and simulations conducted to obtain the approval of the Minister of Construction based on Article 38 of the Building Standards Law. Other important matters such as reliability of shutting, endurance of the silica cloth and changes in the properties of the silica cloth with time are yet to be confirmed. To this end, periodical checks will be carried out on the motional performance after completion and the tensile strength of the silica cloth.

The fire-resistant screen described in this paper has utility value as a fire and smoke shutter in conventional buildings as well as large spaces. We have already adapted these screens to several buildings other than the multipurpose gymnasium introduced in this paper. They only weigh a tenth as much as conventional metal fire and smoke shutters, so people trying to escape will not be trapped or squashed by them. In addition, if a part of the screen enables people to go through it like a door, people will not get trapped in a burning room even after the screens are deployed, and they will not panic. Further improvements of this screen system should be made and it would be useful to aim at safer and more effective systems for preventing fire from spreading.

## ACKNOWLEDGMENTS

This research and development was supported by Sanwa Shutter Corporation and Unitika Glass Fiber Co.,Ltd, and we would like to acknowledge here the considerable assistance of these organizations.

## REFERENCES

- 1.Muraoka, K.,Honma, M.,Miyagawa,Y:"Development of Walk-Through-Type Fire Resistant Screens", (In Japanese), Report of Obayashi Corporation Technical Research Institute, No 52, pp 135-140,1996.
- 2.Tanaka,T:"A model of multiroom fire spread",NBSIR 83-2718,NBS,1983.