

LIBRARY REFERENCE ONLY

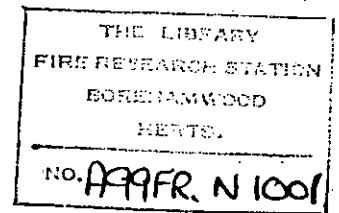

## Fire Research Note No 1001

EFFICIENT EXTRACTION OF SMOKE FROM A  
THIN LAYER UNDER A CEILING

by

D Spratt and A J M Heselden

February 1974

FIRE  
RESEARCH  
STATION

**50376**

**Fire Research Station  
BOREHAMWOOD  
Hertfordshire  
WD6 2BL**

**Tel: 01 953 6177**

EFFICIENT EXTRACTION OF SMOKE FROM A THIN LAYER  
UNDER A CEILING

by

D. Spratt and A.J.M. Heselden

SUMMARY

A method of smoke control has been advocated in which smoky gases generated by a fire are extracted at ceiling level from the layer they form there because they are buoyant. However too high an extraction rate at a given point will draw up air from underneath the layer into the extraction duct and this will markedly reduce the actual amount of smoky gases removed.

This note reports experiments showing that the maximum extraction rate before air is drawn up depends mainly on the layer depth and temperature and is not sensitive to the area or shape of the extraction opening over the range of areas of major practical importance. An expression, derived from large and small-scale experiments, is given for this maximum extraction rate.

In practice, to achieve a rate of removal of smoke equal to the rate at which a fire is producing it, extraction at a number of well-separated points may be necessary.

A very simple expression has been derived from this work for the maximum size for a vent in the form of a simple opening in a flat roof, if entrainment and hence inefficient extraction are to be avoided.

**Crown copyright**

This report has not been published and should be considered as confidential advance information. No reference should be made to it in any publication without the written consent of the Head of Fire Research.

EFFICIENT EXTRACTION OF SMOKE FROM A THIN LAYER  
UNDER A CEILING

by

D. Spratt and A.J.M. Heselden

## 1. INTRODUCTION

To prevent excessive travel of smoke along a covered pedestrian mall in the event of a fire, a system has been advocated<sup>1</sup> in which smoke is extracted at ceiling level from reservoirs. The extraction may be by mechanical means, or by natural venting. Large scale experiments<sup>2</sup> demonstrated the effectiveness of such a system, but showed that the rate of extraction of the smoke may be high enough to cause air underneath the smoke layer to be drawn up and mixed with the outgoing smoke\*. An inverted 'funnel-shaped' flow system was then seen<sup>2</sup>. As much as half of the gases extracted was found to be air drawn up in this way. This effect, arising from trying to extract smoke from a relatively thin layer at too high an extraction velocity, is undesirable since ideally an efficient extract system should extract only smoke and not expend energy on extracting air. Furthermore, when the extraction is by means of natural venting, particularly when the opening from the ceiling is connected to a shaft or chimney, the air drawn up may cool the gases so much that their buoyancy is reduced to a level at which the vent is not capable of extracting so much gas as when the gases are hot. The effect was also explored in a model<sup>3</sup> which was scaled down from the large-scale building<sup>2</sup> and had a shaft or 'chimney' vent. This had been set up to examine the effects of factors such as depth of roof screen, size and shape of vent area etc., more readily than would be possible with the large-scale building. An attempt was made in this model to reduce the air entrainment by placing boards horizontally at various distances beneath the opening to the shaft. However, this was not found to be an effective solution, apparently because the boards

---

\*This air flow is not caused by the same process as that of the entrainment of the air into the hot smoke layer as it flows along under the ceiling of the mall but, for simplicity, we shall refer in this report to the 'drawing up' of the cool air as entrainment.

introduced a substantial resistance to flow up the vent, so that the actual rate of flow of smoke out of the arcade was not in fact increased.

The experiments described in this report were therefore carried out, first of all in this model, and later in the large-scale building, to determine the relationships between the area, shape and position of openings on the maximum rate at which hot gases could be extracted before entrainment occurred.

## 2. EXPERIMENTAL ARRANGEMENTS

The model used<sup>3</sup> (Fig. 1) was essentially a scaled-down version of the large-scale arcade but no attempt was made to reproduce precisely the finer details of the large-scale building. The fire consisted of two sheet steel trays, each 190 mm x 100 mm, containing 200 ml of methylated spirit, separated by 200 mm and placed at the back of the model, which was lined with a ceramic-fibre felt to reduce heat losses. This fire was chosen by experiment so as to give vertical temperature profiles in the 'arcade' very similar to those obtained at corresponding points in the large-scale experiments. The natural venting system (which relies on the buoyancy of the hot gases) was replaced by one having the same dimensions, when scaled-down, of the opening in the ceiling of the large-scale arcade, but connected to an external extractor fan and damper so that the extraction flow rate could be varied. The flow rate of the hot gases extracted in this way was measured by means of an orifice plate and pressure tapings; a thermometer was inserted near the orifice plate. By partially closing the bottom of the vent, various shapes and areas of the opening through which gases were extracted were produced. Tests were also carried out in this model using a much larger vent, with the same extraction system, varying the size and shape as before. This also enabled the effect of positioning the vent at the side or at the centre of the mall to be studied; the various configurations of opening are shown in Fig. 2. The vent in the large-scale arcade had to be placed at the side, out of the way of the framework supporting the roof of the enclosing building. Some of the model conditions had to imitate this, but since extraction in practice might be from various positions it was thought necessary for the model experiments also to include extraction from the centre of the arcade. In all the tests, the experimental arrangement was otherwise identical to that described by Heselden and Fink<sup>3</sup>.

In all cases the point at which no entrainment occurred (the 'critical' extraction rate) was observed by introducing slightly warm smoke into the cool gases at the entrance to the model. This smoke then flowed along into the fire compartment, collecting in a band at the junction between the air flowing in at a low level and the hot gases flowing out at high level. It was burned up in the flame (which itself produced only hot gas without smoke) or at least was very greatly diluted in the plume above the flame. Thus the hot gas layer was clear, and any entrainment which occurred could be easily seen as an inverted funnel-shaped flow of the indicating smoke at the base of the vent shaft. The extraction rate was reduced until the point was reached where this entrainment ceased and the pressure drop and temperature readings at the orifice were noted.

The effect of altering the depth of screen 'A' (Fig. 1) was also noted. This was done for the case where the vent was in the centre of the mall, the screen depth being varied from 225 mm in steps down to zero.

In order to check the validity of extrapolating to a large scale the results of the model experiments, tests were carried out in the large-scale building. Three tests were carried out with fires of industrial methylated spirit burnt in trays of area  $0.76 \text{ m}^2$ ,  $1.62 \text{ m}^2$ , and  $3.02 \text{ m}^2$ . Smoke was introduced at low level under the vent, as in the model, and the top of the vent partially covered with sheets of asbestos until the condition was just reached where no entrainment was observed. The flow velocity of hot gases up the vent was then measured with a vane anemometer and the temperature of the hot gases under the vent obtained from thermocouples placed in this position.

### 3. RESULTS AND DISCUSSION

#### 3.1 Model experiments

The values of maximum volume flow rate of gases through the vent before entrainment occurred have been reduced to ambient temperature, thus providing a volume flow rate proportional to mass flow rate. The results are given in Table 1 and are plotted against vent area in Fig. 3.

Table 1

Experimental results obtained from arcade model

In all cases the temperature of the hot gases below the vent was 208°C (481°K)

Symbol used in Figs 3 and 4	Vent size		Vent area (m <sup>2</sup> )	Flow rate through opening (m <sup>3</sup> /s) at 20°C	
	Length l (mm)	Width w (mm)			
△	365	365	0.133	0.030 (3)	
	"	320	0.117		
	"	273	0.100		
	"	227	0.083		
	"	182	0.066		
	"	136	0.050		
	"	91	0.033		0.018 (2)
	"	45	0.016		
○	365	91	0.033	0.018 (2)	
	273	"	0.025		
	182	"	0.017		
	91	"	0.008		
□	365	45	0.016	0.018 (2)	
	273	"	0.012		
	182	"	0.008		
	91	"	0.004		
	45	"	0.002		
▼	365	365	0.133	0.030 (3)	
	320	"	0.117		
	273	"	0.100		
	227	"	0.083		
	182	"	0.066		
	136	"	0.050		
	91	"	0.033		
	45	"	0.016		
■	365	365	0.133	0.030 (3)	
	"	320	0.117		
	"	273	0.100		
	"	227	0.083		
	"	182	0.066		
	"	136	0.050		
	"	91	0.033		
	"	45	0.016		

( ) Average of number of tests

With the opening near the side of the mall Fig. 3 shows that the maximum rate at which gases can be extracted without entrainment of air is independent of both the shape of the opening and the area, between areas of 0.01 and 0.05 m<sup>2</sup>.

In terms of the efficient mechanical extraction of smoke in a real situation this means that what affects the total amount of smoke which can be extracted is the number of separate extraction points, not their individual or total areas. In a real situation smoke extraction would usually have to be made by extracting at a number of points, sufficiently separated to avoid mutual interference, rather than at one point.

In terms of extraction by natural venting the amount of gases required to be vented will determine the height and total cross-sectional area of the vent shafts. The amount of gas which can be efficiently extracted by one opening, obtained in principle from Fig. 3, then determines how many extract points are required.

With very small openings a higher extraction rate is possible before entrainment. In practice this could generally be achieved only by a mechanical extraction system and the question of whether the small opening would cause an uneconomically large pressure drop in the extraction system would have to be examined. A large number of very small, well separated openings would be particularly good for extraction.

With the very large openings Fig. 3 shows that a higher extraction rate is possible, but this is largely of academic interest since at opening areas larger than those marked 'A' (see Section 3.3) it is not a question of pulling gases out of the model but of preventing them from rising through large vent openings too rapidly, by restricting the flow higher up. In practice there is normally no point in providing a larger opening than necessary but such a situation might occasionally arise with a false ceiling or extraction within an upstand. The main region of interest and practical importance is the flat region where the flow is a minimum and openings are relatively small.

The velocity in the vent tends to a constant value of about 0.2 m/s (Fig. 4) at very high vent areas and this is only about one-quarter of the vertical velocity at the ceiling that would be generated by the buoyancy of the layer in the mall.



With the opening at the centre, a higher extraction rate is possible before entrainment because the wall no longer prevents hot gases from flowing evenly into the vent from all sides. A substantial practical advantage can thus be gained by extraction from the centre of the mall, where the various constraints of the building permit this.

The effect of altering the depth of the layer, by altering the depth of the ceiling screen ('A' in Fig. 1), is shown in Fig. 5. For the tests described above, the screen was 135 mm deep, which corresponds to the 0.9 m deep screen in the large-scale building, but increasing the depth of the screen to 200 mm (Fig. 5) increases the maximum flow rate before entrainment occurs. Deepening the screen still further does not increase this flow rate because the stage has been reached where all the hot gases have been confined behind the screen and the depth of the hot gas layer is then constant. Reducing the depth of this screen leads to a corresponding decrease in the maximum extraction rate, and the screen depth is therefore important in the efficient extraction of hot gases from the mall because it influences the depth of the layer.

The extraction of gas at a uniform temperature  $T$  °K and density  $\rho$  at an actual volume flow rate of  $\rho_0 V/\rho$  (i.e. a volume flow rate  $V$  expressed at ambient temperature) from a small opening would be expected to produce a velocity towards the opening proportional to  $\rho_0 V/\rho r^2$  at a distance  $r$  from the opening, corresponding to a force proportional to  $\left(\frac{\rho_0 V}{\rho r^2}\right)^2 \cdot \rho$ ,  $\rho_0$  being the density of the gas at ambient temperature.

If we now consider this gas (largely air) as a layer under a ceiling above air of density  $\rho_0$ , the buoyancy force at the ceiling is  $(\rho_0 - \rho)g d_b$  where  $d_b$  is the depth of the layer.

It is likely that the critical conditions for the onset of entrainment occur when the ratio of these two kinds of forces has a particular value, i.e.

$$\frac{\left(\frac{\rho_0 V}{\rho r^2}\right)^2 \cdot \rho}{(\rho_0 - \rho) g d_b} = \text{constant}$$

We put  $r \propto d_b$ , the layer depth, so that

$$V \propto \left( \frac{g \rho (\rho_0 - \rho)}{\rho_0^2} \right)^{1/2} \cdot d_b^{5/2}$$

or

$$V \propto \left( \frac{g T_0 \theta}{T^2} \right)^{1/2} \cdot d_b^{5/2}$$

where  $\theta$  is the temperature excess of the layer above the air at absolute temperature  $T_0$ , and  $T$  is the absolute temperature of the layer.

A regression analysis of the relationship  $V = a (d_b)^n$  where  $a$  and  $n$  are constants gave  $n = 2.8$ , with 95 per cent confidence limits of 1.2 and 4.4, so that the theoretical value of 2.5 is in accordance with the experimental data.

The mean value of  $V / \left( \frac{T_0 \theta}{T^2} \cdot g \cdot d_b^5 \right)^{1/2}$  for the data is 1.33 (dimensionless).

### 3.2 Large-scale tests

The data obtained from the large-scale tests, given in Table 2, can be combined with the small scale data in a generalised relationship very similar to that obtained by varying the depth of the screen in the model. No measurements are available of the layer depth in these large-scale tests and  $d_b$  must therefore be replaced by  $d_s$ , the depth of the screen. This is permissible because the layer depth depends closely on the screen depth.

Table 2

Experimental results obtained from large-scale building

Test No.	Area of tray used for fire (m <sup>2</sup> )	Vent size		Area of opening at bottom of vent shaft (m <sup>2</sup> )	Flow rate through opening (m <sup>3</sup> /s) at 20°C	Temperature above ambient at base of vent shaft $\theta_c$ degC
		Length (m)	Width (m)			
141.	0.76	2.44	0.61	1.49	1.63	59
142	1.62	2.44	0.61	1.49	1.95	118
143	3.02	2.44	0.61	1.49	3.01	199

The flow was produced by the buoyancy of the gases in the vent shaft, corresponding to the horizontal minimum region in the model data of Fig. 3. Values obtained for  $V/\left(\frac{T_0 \theta}{T^2} \cdot g \cdot d_s^5\right)^{1/2}$  for both model and large scale data given in Table 3 are in satisfactory agreement, remembering that the linear dimensions of the large-scale building are nearly 7 times those of the model.

Table 3

Comparison of large-scale and model data  
(Extraction opening at side)

Experiments	$\frac{V}{\left(\frac{T_0 \theta}{T^2} \cdot g \cdot d_s^5\right)^{1/2}}$ (dimensionless)								
Model	1.71								
Large-scale	<table style="display: inline-table; vertical-align: middle;"> <tr> <td style="padding-right: 10px;">141</td> <td style="padding-right: 10px;">1.80</td> <td rowspan="3" style="font-size: 2em; padding: 0 10px;">}</td> <td rowspan="3" style="vertical-align: middle;">mean 2.0</td> </tr> <tr> <td>142</td> <td>1.78</td> </tr> <tr> <td>143</td> <td>2.54</td> </tr> </table>	141	1.80	}	mean 2.0	142	1.78	143	2.54
141	1.80	}	mean 2.0						
142	1.78								
143	2.54								

The values given in Table 3 using  $d_s$  are larger than the value of 1.33 for  $V/\left(\frac{T_0 \theta}{T^2} \cdot g \cdot d_b^5\right)^{1/2}$  (using  $d_b$ ) obtained above by varying the screen depth in the model experiments, because the layer depth is usually a little larger than the depth of the screen.

The mean value of  $V/\left(\frac{T_0 \theta}{T^2} \cdot g \cdot d_s^5\right)^{1/2}$  for the large-scale data is 2.0:

### 3.3 Limitations on size of simple roof vent

Combining the relationship obtained in 3.2 with that for the natural buoyancy flow out of an opening in a flat roof, (i.e. a 'hole' rather than a 'chimney') leads to a very simple connection between the screen depth and the maximum size of vent opening that is possible without entrainment.

For the situation and nomenclature in Fig. 6 the mass flow through the vent ( $M_v$ ) will be<sup>4</sup>

$$M_v = \frac{C_v \cdot A_v \rho_0 (2g d_b \theta T_0)^{1/2}}{T} \dots\dots (1)$$

where  $C_v$  is the discharge coefficient

The large-scale experiments described above (extraction opening near a wall) yield a value for the critical volume rate of extraction before entrainment of :

$$\frac{2.0 (g d_s^5 \theta T_0)^{1/2}}{T}$$

or a mass rate of extraction  $M_{crit}$  of :

$$M_{crit} = \frac{2.0 \rho_0 (g d_s^5 \theta T_0)^{1/2}}{T} \dots\dots (2)$$

For a suitably designed vent  $d_b = d_s$ , then assuming  $C_v = 0.6$  and combining (1) and (2)

$$\begin{aligned} M_{crit} &= \frac{2^{1/2} d_s^2}{0.6 A_v} \cdot M_v \\ &= \frac{2.4 d_s^2}{A_v} \cdot M_v \end{aligned}$$

For no entrainment we require

$$\begin{aligned} M_{crit} &> M_v \\ \text{i.e.} \quad \frac{2.4 d_s^2}{A_v} &> 1 \\ \text{or} \quad A_v &< 2.4 d_s^2 \dots\dots (3) \end{aligned}$$

Hence, if entrainment is to be avoided and the extraction is to be efficient the vent area should not be larger than  $2.4 d_s^2$ ,  $d_s$  being the depth of the screen. If the vents are square, then this is equivalent to a condition that the side dimension of the vent should not be more than 50 per cent larger than the screen depth.

For an extraction opening well removed from a wall, (3) becomes

$$A_v < 3.4 d_s^2 \dots\dots (4)$$

(4) has been obtained from (3) by applying the difference between the critical rates for centre and for side extraction found in the model data plotted in Fig. 3.

The values for the largest simple vent openings before entrainment given by (3) and (4) are marked ('A') in Fig. 3, for the screen depth used in those experiments (0.135 m).

### 3.4 Example of application

As an illustration of the importance of these results consider test 129 described in a previous report<sup>2\*</sup>. The shaft vent installed in this experiment had an opening into the mall of area 1.44 m<sup>2</sup> and could extract about 4 m<sup>3</sup>/s of hot gases (expressed at ambient temperature). At first sight it seems that it should have been capable of removing nearly all the hot gases containing smoke that flowed along the mall just upstream of the vent (5.0 m<sup>3</sup>/s). However, it was found in practice that the extraction was only partially successful, since air was drawn up at the base of the vent, and 2.5 m<sup>3</sup>/s of hot gases reached the end of the mall and passed under the screen there.

The large scale data give a mean value of  $V / \left( \frac{T_0 \theta}{T^2} g \cdot d_s^5 \right)^{1/2}$  of 2.0 which, inserting values for  $d_s$ ,  $\theta$ ,  $T_0$ , and  $g$  of 0.9 m, 180°C, 293°K and 9.8 m/s<sup>2</sup>, respectively gives  $V = 2.8 \text{ m}^3/\text{s}$ . This shows that the shaft vent was made too large. To avoid air entrainment it should have been made with a cross-sectional area not larger than  $1.44 \times 2.8/4 = 1.0 \text{ m}^2$ , two-thirds its existing area, when it could have extracted, by its natural venting action, up to 2.8 m<sup>3</sup>/s of gas without air entrainment. In order to extract all the smoky gases produced from the fire two vents would be required, well separated to avoid mutual interference.

Extraction by mechanical means could be made through smaller openings, but it would still be necessary to extract at 2 or 3 separated points unless the openings were made very small indeed -

---

\*Especially Table 5 and Fig. 16

in the region of  $0.16 \text{ m}^2$  or less - when the pressure losses at the opening or in the ductwork might be unacceptably high.

#### 4. CONCLUSIONS

1. When the rate of extraction of smoky hot gases from a layer under a ceiling exceeds a critical value at any point then air from beneath the layer is drawn up, giving an inefficient extraction.
2. The maximum amount of smoky hot gases which can be extracted before air is drawn up is not sensitive to the area or shape of the opening over the range of areas of major practical importance. It depends to some extent on the temperature of the gases. It is reduced by placing the extraction opening near a wall.
3. The maximum extraction rate increases markedly as the depth of the hot gas layer is increased.
4. A law of the form  $V \propto \left( \frac{T_0 \theta}{T_2} \cdot g \cdot d_s^5 \right)^{1/2}$  fits the data from both the model and the large-scale experiments and has a partial theoretical justification. Thus, although most of the data were obtained from model experiments, the results are confirmed by the few large-scale experiments carried out.
5. The spacing that is necessary between extract points to avoid undue interference needs to be studied.

#### 5. ACKNOWLEDGMENTS

The authors would like to thank Mr. P. L. Hinkley for helpful discussions and Messrs H.G.H. Wraight, M. L. Bullen and N. R. Marshall for their assistance with the experimental work.

#### 6. REFERENCES

1. HINKLEY, P. L. Some notes on the control of smoke in enclosed shopping centres. Joint Fire Research Organization F.R. Note No. 875, 1971.
2. HESELDEN, A.J.M. et al. Fire problems of pedestrian precincts. Part 2. Large scale experiments with a shaft vent. Joint Fire Research Organization F.R. Note No. 954, 1972.
3. HESELDEN, A.J.M. and FINK, S.W. Fire problems of pedestrian precincts. Venting studies with a hot model. Joint Fire Research Organization F.R. Note (in preparation).
4. THOMAS, P. H. et al. Investigations into the flow of hot gases in roof venting. Fire Research Technical Paper No. 7. London, 1963. H.M. Stationery Office.

--- Scaled down position of vent in large scale building

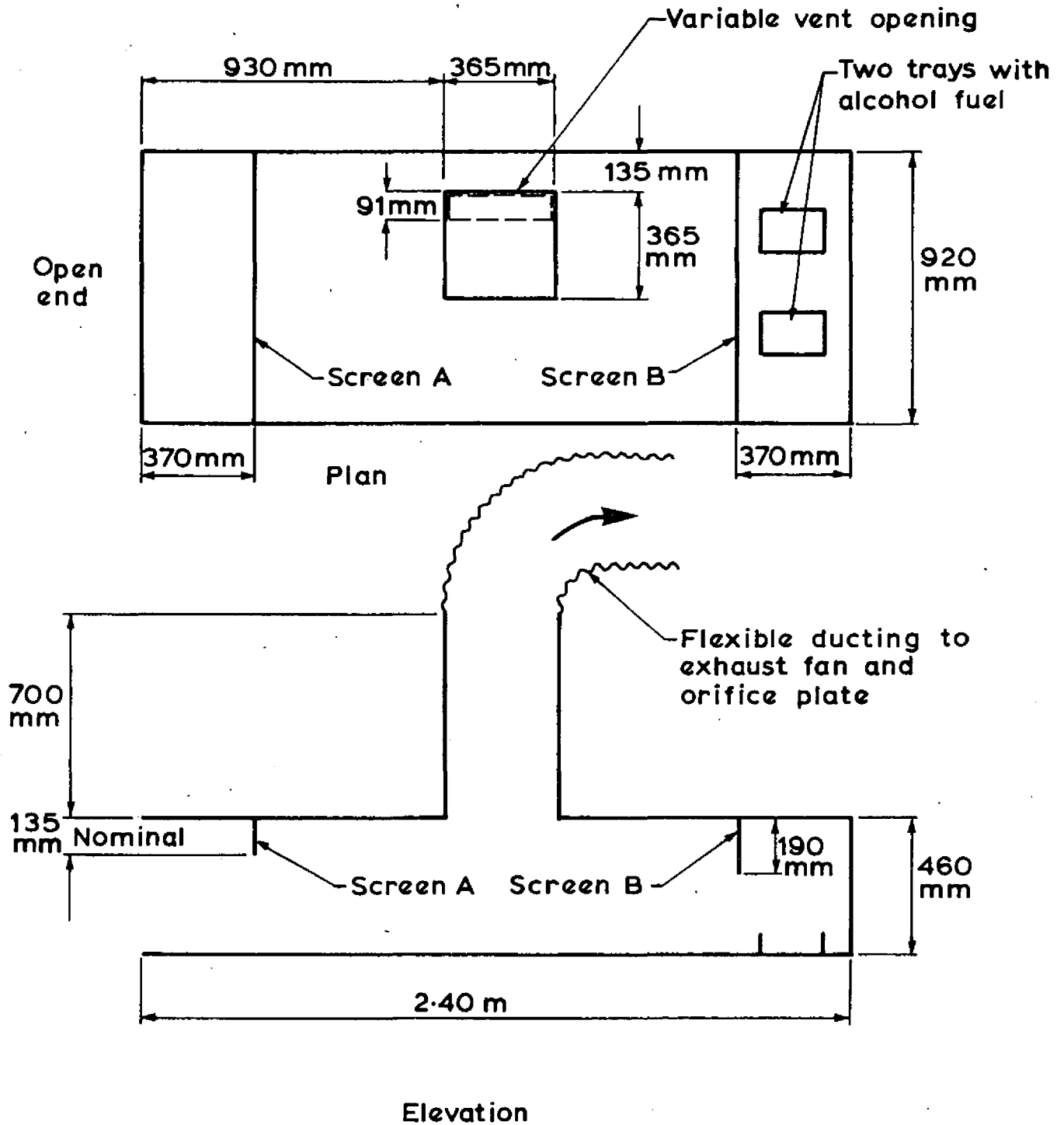

Scale of model:  $\frac{3}{20}$  full size

Figure 1 Diagrammatic representation of model of large-scale building

Symbol used

Plan of model showing how vent area was increased

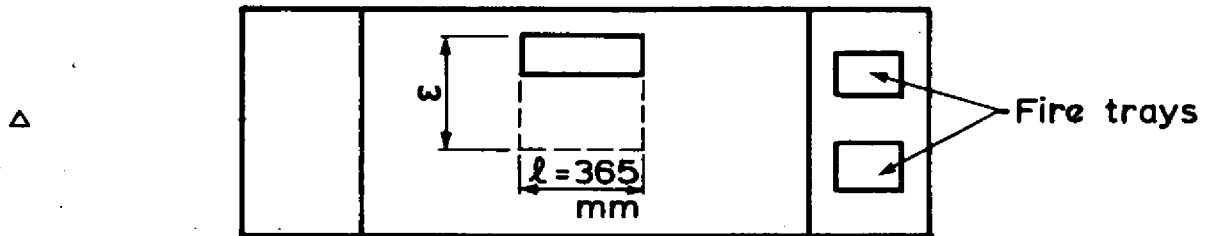

Width of vent ( $w$ ) increased from side of mall to centre

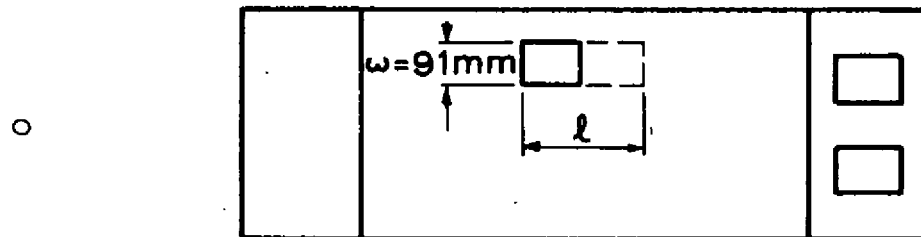

Length of vent ( $l$ ) increased with vent at side of mall

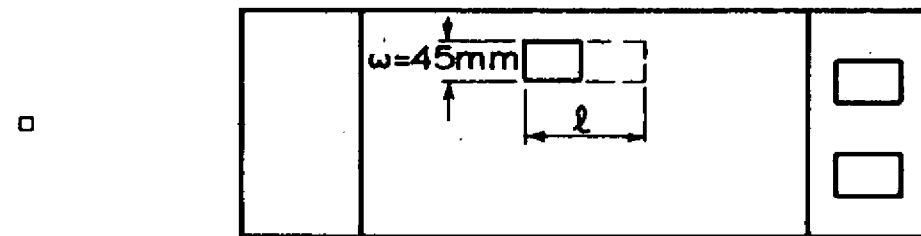

$l$  increased with vent at side of mall

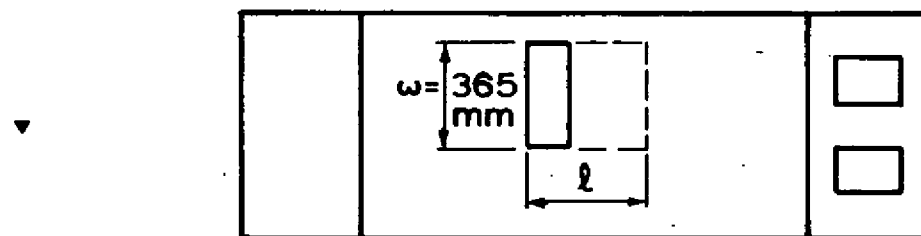

$l$  increased with  $w = 365$  mm

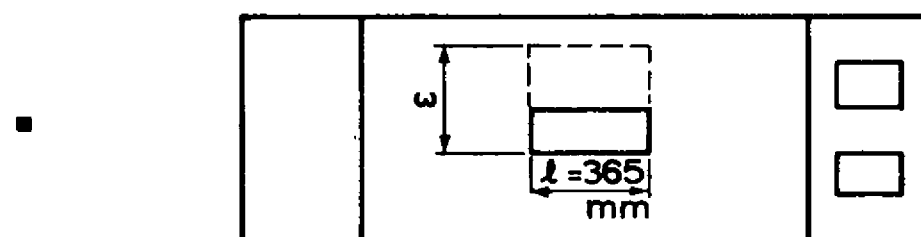

Width of vent ( $w$ ) increased from centre to side of mall

Figure 2 Key to figures 3 and 4



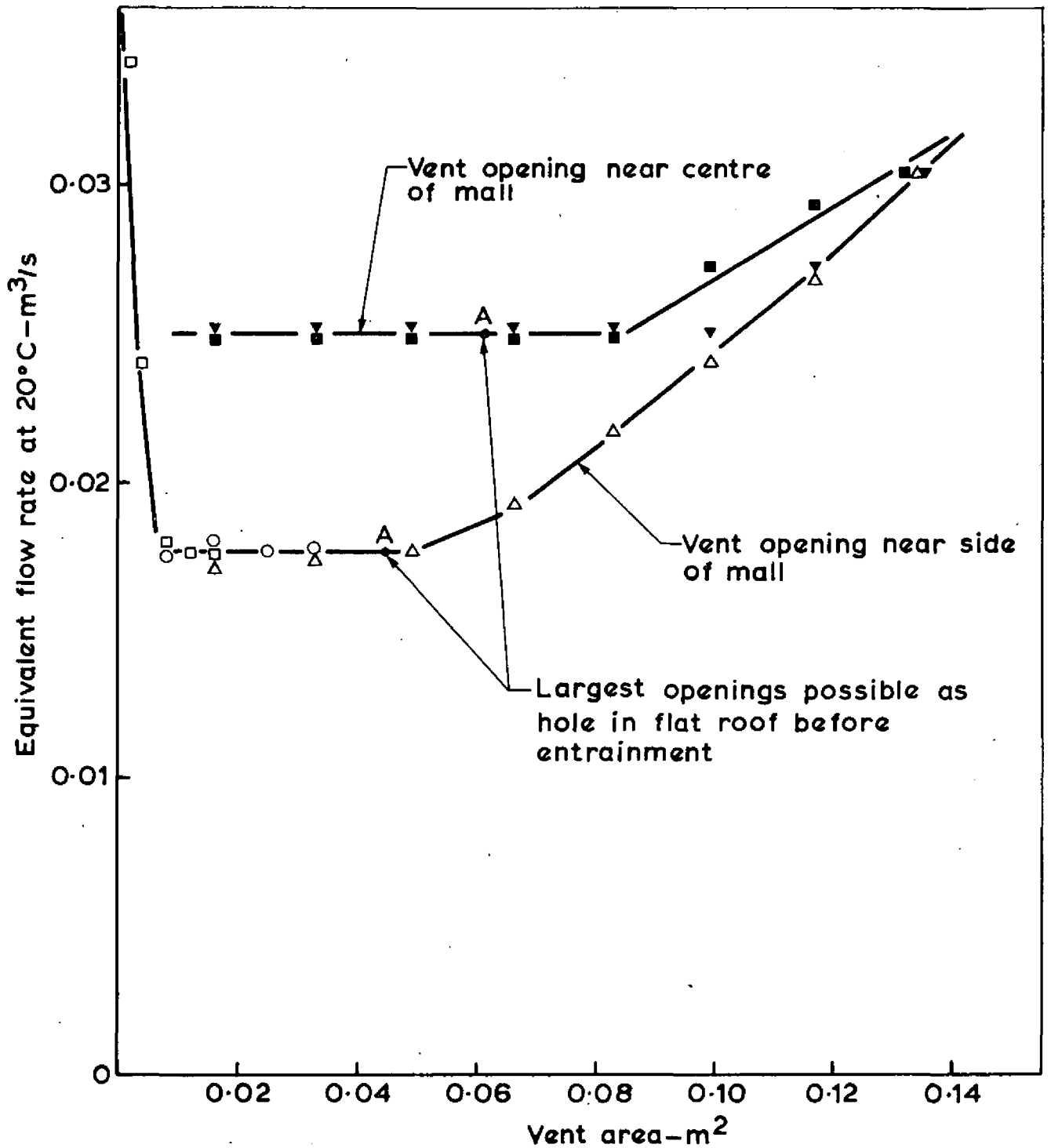

Figure 3 Maximum flow rate possible through vent before entrainment occurs (model results)

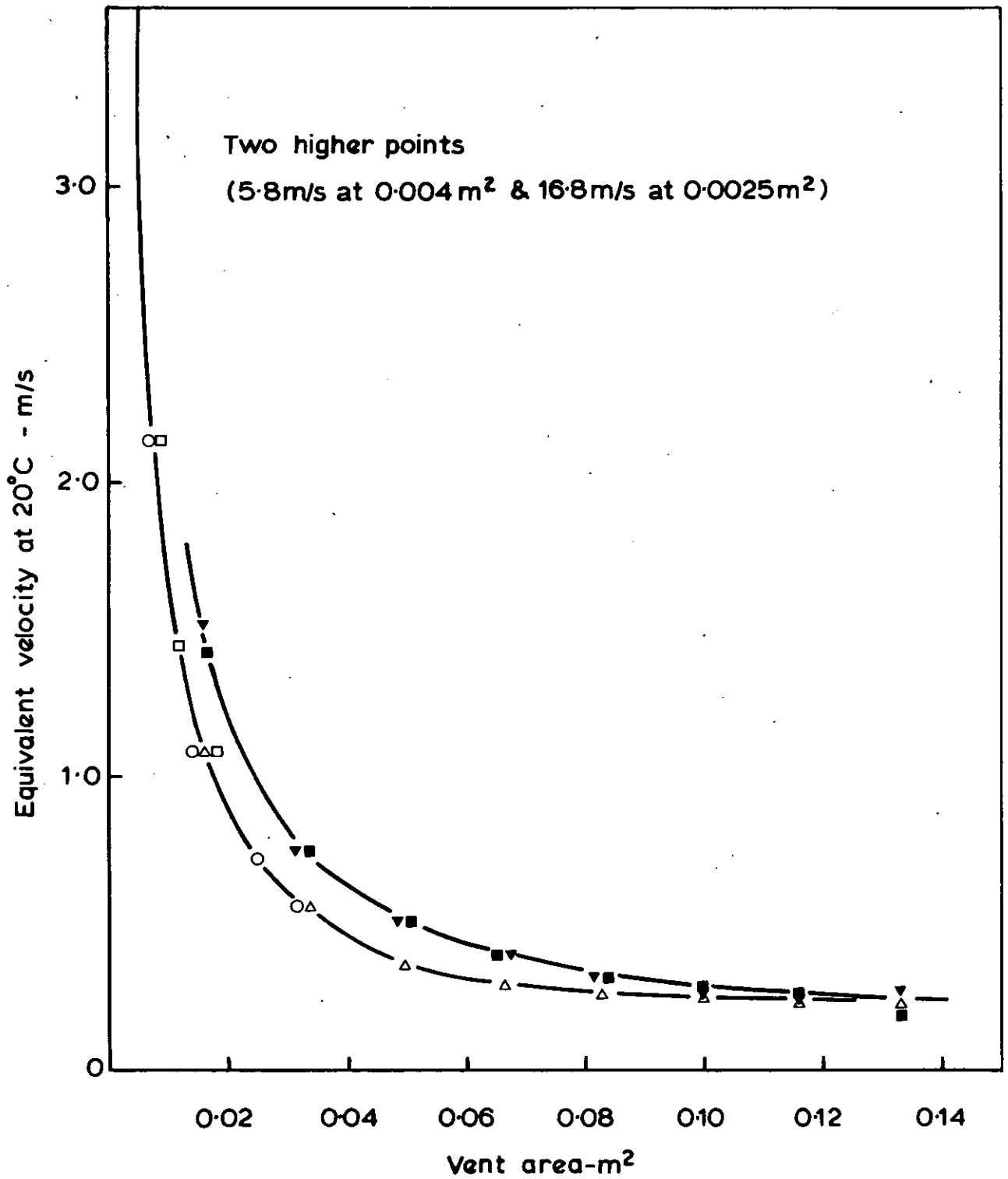
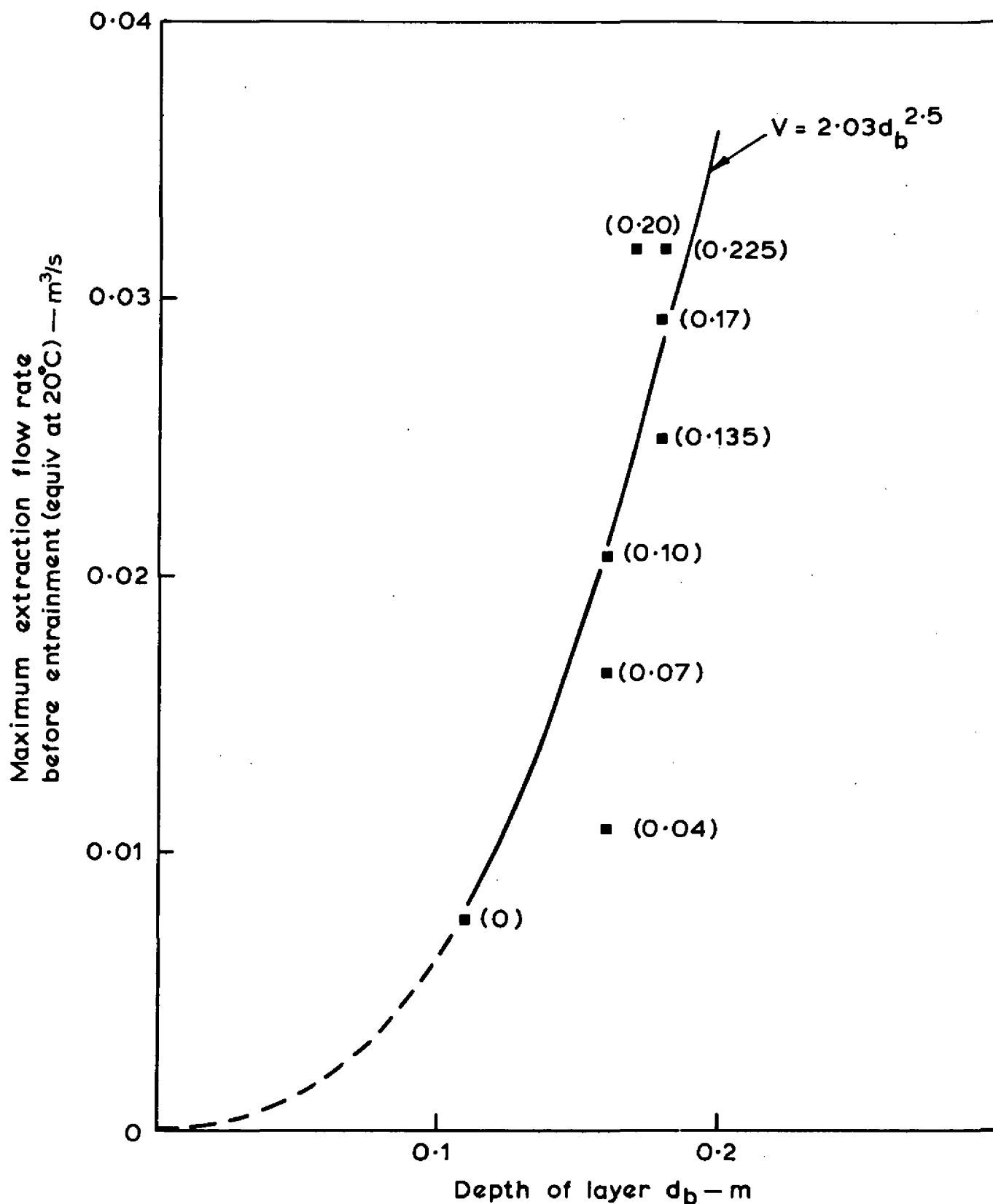

Figure 4 Maximum velocity possible in vent before entrainment occurs(model results)



Numbers against each point are the screen depths in m

Figure 5 Effect of layer depth on extraction rate (model results)

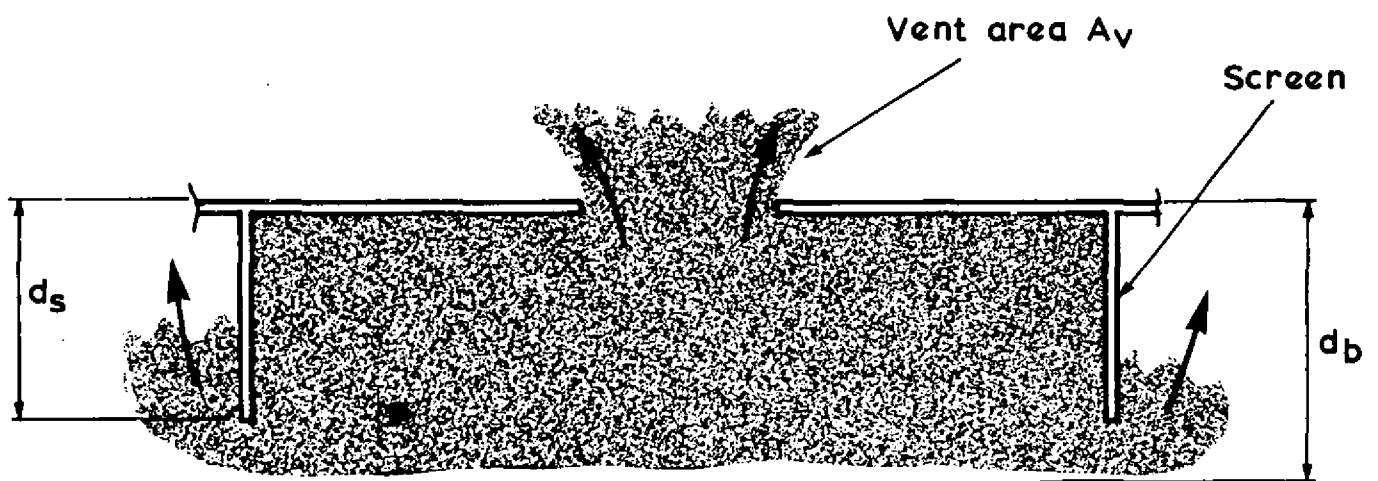

Figure 6 Natural buoyancy flow through a simple opening in a flat roof