

LIBRARY REFERENCE ONLY

Library

DIR AND FOC
FIRE RESEARCH
ORGANIZATION
REFERENCE LIBRARY
No. AC9FR.114

F.R. Note No. 114

DEPARTMENT OF SCIENTIFIC AND INDUSTRIAL RESEARCH AND FIRE OFFICES' COMMITTEE
JOINT FIRE RESEARCH ORGANIZATION

This report has not been published and should be considered as confidential advance information. No reference should be made to it in any publication without the written consent of the Director, Fire Research Station, Boreham Wood, Herts. (Telephone: ELStree 1341 and 1797).

PROPOSED DESIGN OF A POWER SUPPLY
FOR A
HIGH CURRENT CARBON ARC

by

R. W. Pickard

June, 1954.

Fire Research Station,
Station Road,
Boreham Wood, Herts.

PROPOSED DESIGN OF A POWER SUPPLY
FOR A
HIGH CURRENT CARBON ARC

by

R. W. Pickard

1. Introduction

A high current carbon arc operating at 75 volts and 150 amps D.C. has been used as a source of high intensity radiation. At present the power is derived from a 22 K.W. Diesel generating set. Owing to the inconvenience of this type of supply, a three phase bridge rectifier system was proposed. This note deals with the design of the rectifiers and transformer required.

The circuit proposed was a three phase, full wave single and a diagram is given in Fig. 1.

2. Requirements of the power supply

The power supply is required to deliver 75 volts and 150 amps D.C. at the arc. The arc itself is fed through a cable and ballast resistor such that the total resistance is about 0.1 ohm. When a current of 150 amps is flowing this will result in a voltage drop of about 15 volts between the power supply and the arc. This factor must be allowed for in designing the supply which should therefore be capable of delivering 90 volts at 150 amps D.C.

3. The rectifiers

The factors governing the type of rectifier to be used are as follows:-

- (1) The output voltage required.
- (2) The output current required.
- (3) The type of circuit used.

Data are available ⁽¹⁾ from which the specification of the rectifiers required can be determined.

If the output D.C. voltage is E

and " " D.C. current is I

then the peak inverse voltage on each rectifier ⁽¹⁾ is 1.05 E and the peak current taken by each rectifier is I. Hence for the power supply in question

Peak inverse voltage = $1.05 \times 90 = 94.5$ volts

Peak current = 150 amps.

A rectifying unit which will satisfy these requirements consists of two rectifiers connected in series having code numbers H/17/2/10/G and H/17/1/10/G manufactured by Standard Telephones and Cables Ltd.,

4. The transformer

The A.C. supply to the rectifier bridge is most conveniently obtained by means of a single three phase transformer. Assuming no voltage drop in the rectifier elements, the line voltage and current requirements can be calculated from available data. ⁽¹⁾ With the rectifier elements proposed it was found, however, (Appendix 1) that a voltage drop of about 4.5 volts was to be expected when a current of 150 amps was flowing, a

factor which must be allowed for when determining the output line voltage of the transformer.

If the D.C. output voltage and current be E and I respectively then the output line voltage (R.M.S.) assuming no rectifier drop (1) is $0.74 E$

If the voltage drop factor be A , then the line voltage required

$$= 0.74E + A. \quad \text{In this case, } A = 6 \text{ (Appendix 1)}$$

$$= 0.74 \times 90 + 6 = 73 \text{ volts.}$$

The output line current = $0.82 I = 0.82 \times 150 = 123$ amps

From the results above the transformer may be specified as a 3 phase transformer with an output line voltage of 73 volts and an output line current of 123 amps. To allow for ageing in the rectifier units the output should be made variable within the following limits:

$\pm 2\frac{1}{2}$ per cent, + 5 per cent and + 10 per cent.

References

1. Reference Data for Radio Engineers, Standard Telephones & Cables Ltd. pp 62-63.

Appendix 1

Determination of the voltage drop factor

The voltage drop which occurs in each rectifier unit when a current of 150 amps is flowing was determined as follows.

A rectifier element of the type H/17/2/10/G was connected in series with a 0.4 ohm variable resistance and an ammeter capable of measuring up to 100 amps. The system was then connected across the 2v, 4v, and 6vappings of a 6 volt accumulator. In each case the current flowing and the voltage developed across the rectifier was noted.

In the proposed circuit each rectifier unit of the bridge will consist of an H/17/2/10/G type in series with an H/17/1/10/G type. The latter rectifier is identical with the type tested except that it consists of half the number of plates and thus a voltage drop of 4.5 volts is to be expected across the combined unit.

The amount by which the transformer line voltage must be increased to account for this may be determined as follows:

The peak current carried by each rectifier unit in the bridge is 150 amps (1) which will produce a voltage drop of 9 volts on each line of the transformer since this current flow through two rectifier units on each line.

Hence the peak line voltage must be increased by 9 volts to allow for this and therefore the R.M.S. line voltage must be increased by 6 volts.

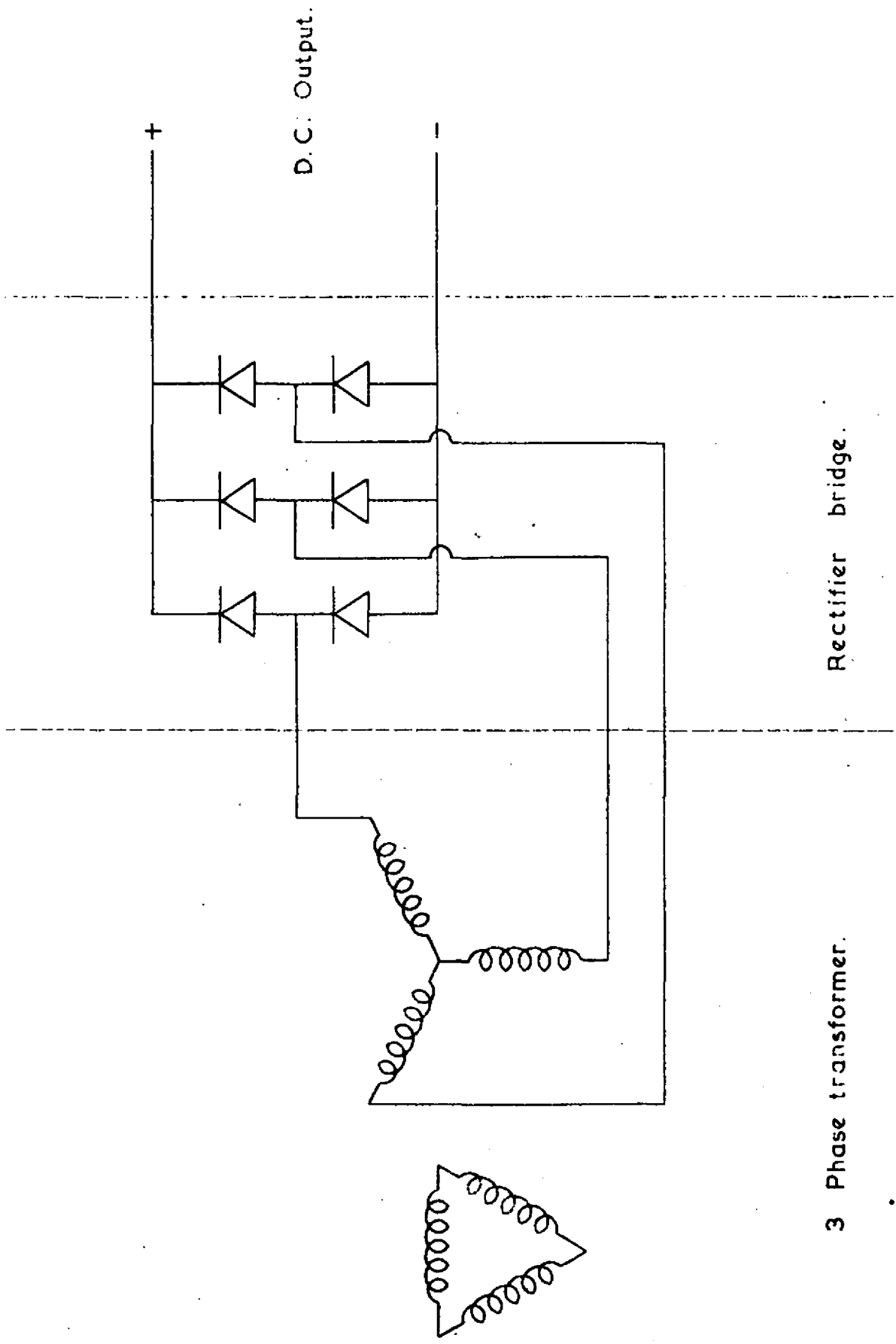

3 Phase transformer.

Rectifier bridge.

D.C. Output.

FIG.1. 3 PHASE POWER SUPPLY.

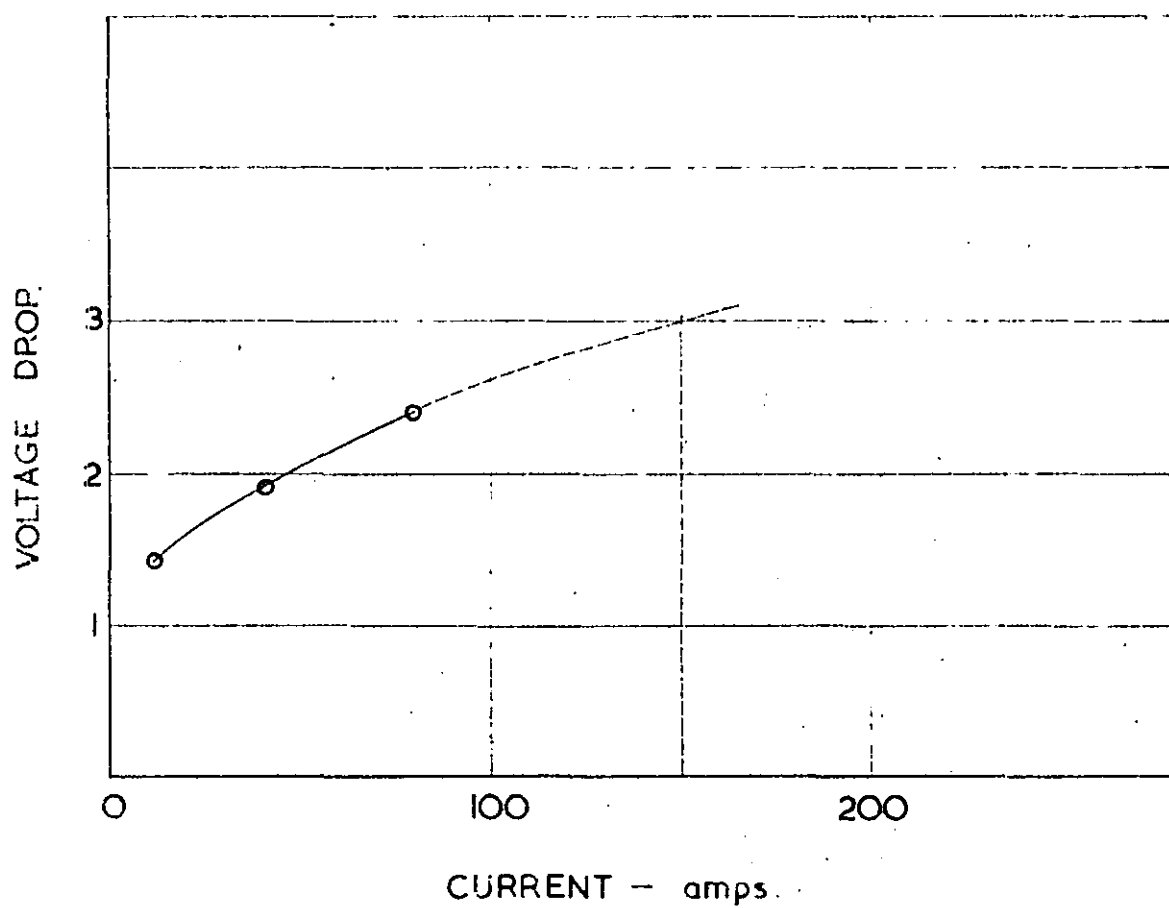

FIG. 2. RECTIFIER VOLTAGE DROP.