

THE LIBRARY
FIRE RESEARCH STATION
BOREHAM WOOD
HERTS.

Fire R. Note No. 405

Research Objective No.

DEPARTMENT OF SCIENTIFIC AND INDUSTRIAL RESEARCH AND FIRE OFFICES' COMMITTEE
JOINT FIRE RESEARCH ORGANIZATION

IMPROVED SUCTION AND DISCHARGE VALVES FOR RECIPROCATING PUMPS

by

J. A. Gordon

Summary

This note describes two types of rubber suction and discharge valves for reciprocating pumps, both of which are simple to produce and effective and reliable in operation.

May 1959

F.1061/17/11

Fire Research Organization,
Boreham Wood,
HERTS.

IMPROVED SUCTION AND DISCHARGE VALVES FOR RECIPROCATING PUMPS

by

J. A. Gordon

Introduction

The efficiency of hand pumps of the reciprocating type is sometimes reduced by the use of unsuitable or inefficient valves. Loss of efficiency is mainly caused by valves which depend on a reversal of flow to close them. The delay thus caused will reduce the effective length of the stroke and impart fluctuations to the discharge stream.

Two types of valve have been designed which eliminate these faults by closing immediately the flow stops. This is achieved by using the elasticity of rubber to hold the valves in close contact with their ports.

Description

Type A. The valve Fig. 1, Plates 1 and 2 is made from $\frac{1}{8}$ in. thick rubber sheet and is secured on each side of the valve port by dome-headed rivets. It is easily replaceable by slipping it over the rivet heads. The same type of valve can be used for both suction and discharge ports.

Type B. The valve Fig. 2, Plates 3 and 4, is made from $\frac{5}{64}$ in. thick rubber sheet, is disc shaped and secured by one central retaining rivet. The rivet head holds the valve in close contact with the valve port which can be a cluster of small holes, equally spaced. The valve can be replaced by slipping it over the rivet head and can be used for either suction or discharge ports.

With type A valve which has to cover a large single orifice a thicker rubber is used than with type B. This is to prevent the rubber from collapsing into the larger port orifice under pressure.

Conclusions

Both types of valve are suitable for either suction or discharge ports, are simple and have been found to be effective and reliable in operation. They could be adapted for use in reciprocating pumps and have been found to be particularly effective in improving the performance of diaphragm pumps.

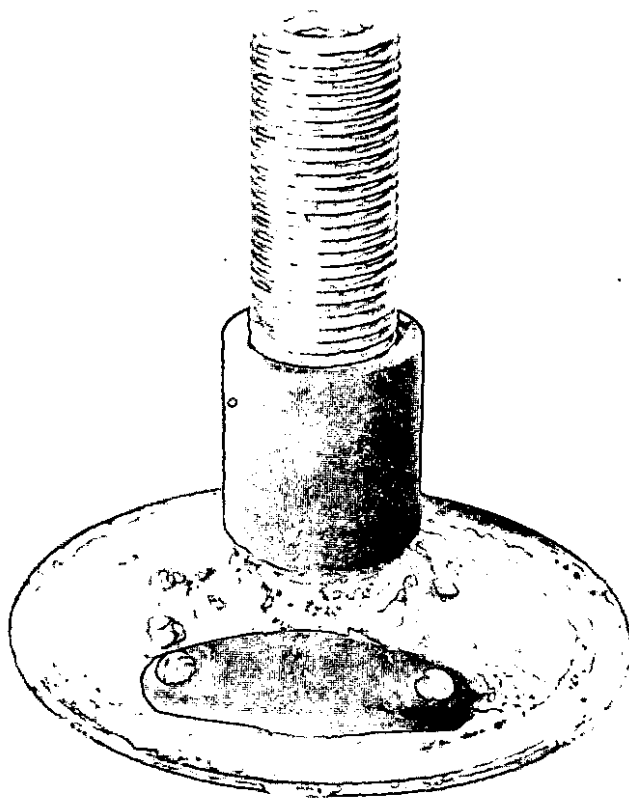

**PLATE 1. RUBBER VALVE FOR RECIPROCATING PUMPS
(DISCHARGE) TYPE A**

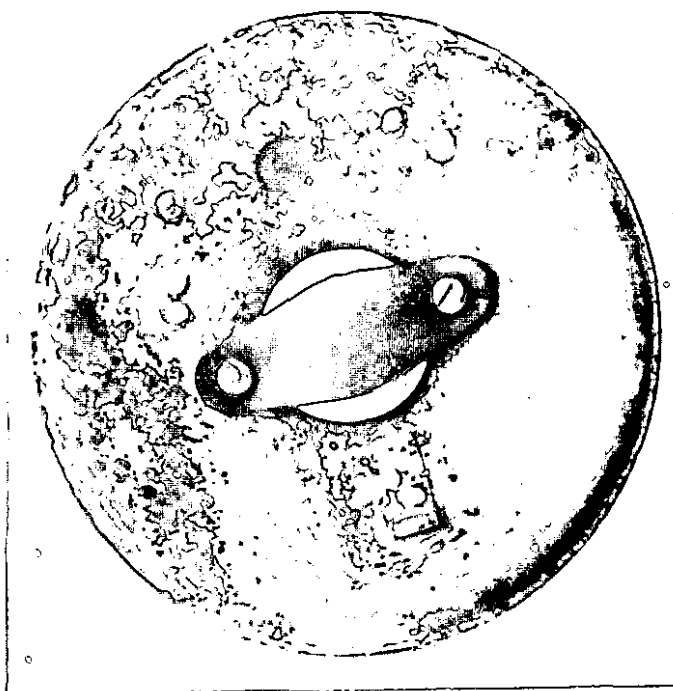

**PLATE 2. RUBBER VALVE FOR RECIPROCATING PUMPS
(SUCTION) TYPE A**

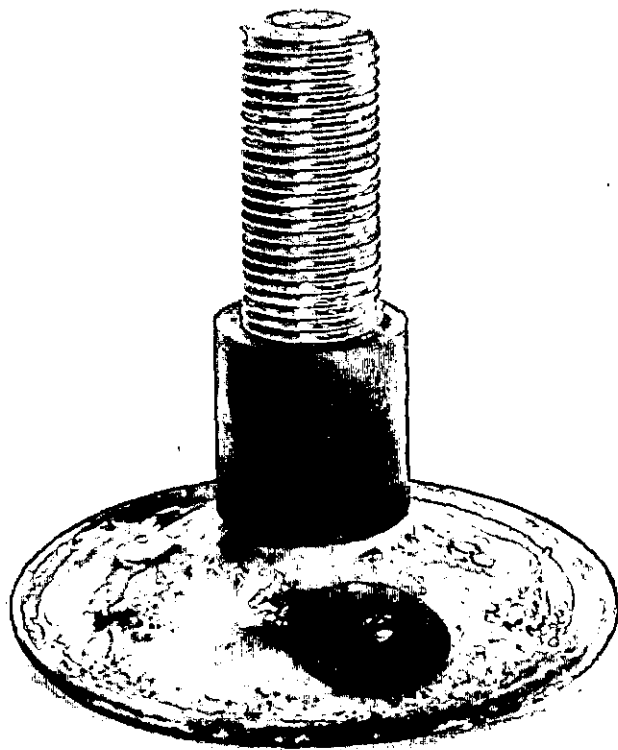

**PLATE 3. RUBBER VALVE FOR RECIPROCATING PUMPS
(DISCHARGE) TYPE B**

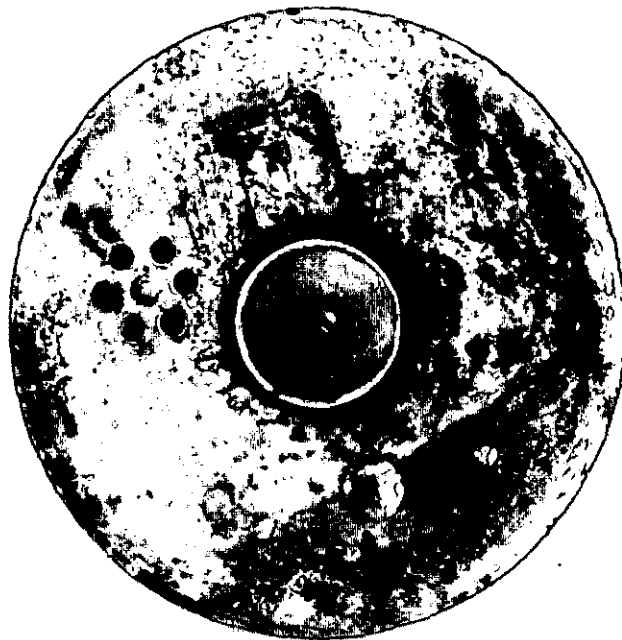

**PLATE 4. RUBBER VALVE FOR RECIPROCATING PUMPS
(SUCTION) TYPE B.**

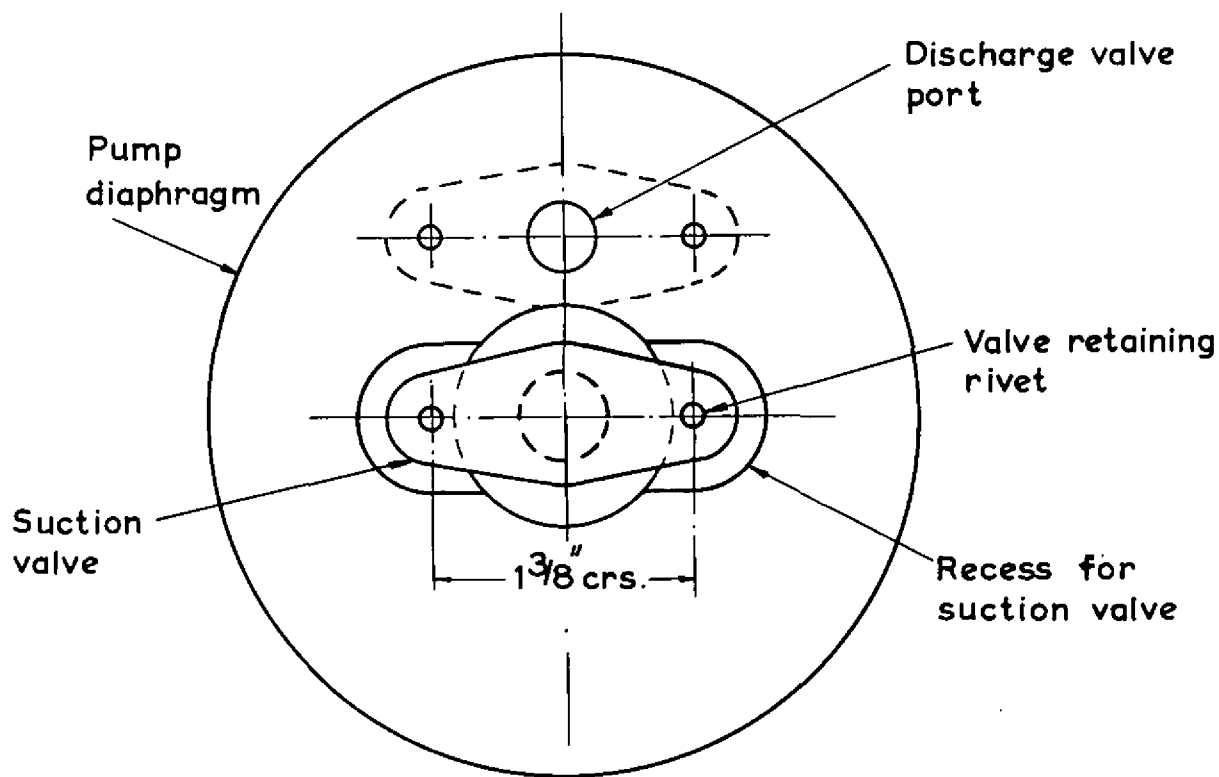

UNDERSIDE OF DIAPHRAGM

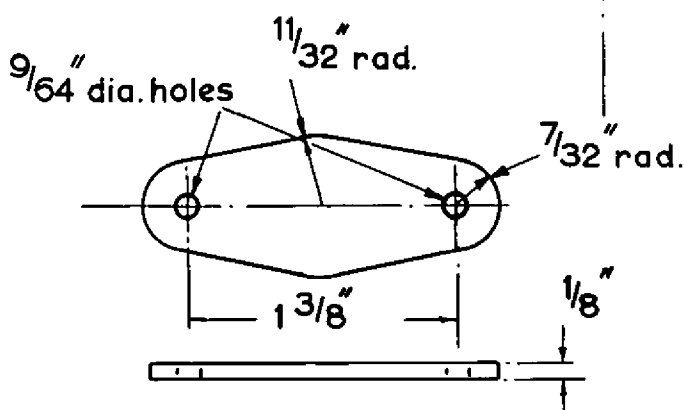
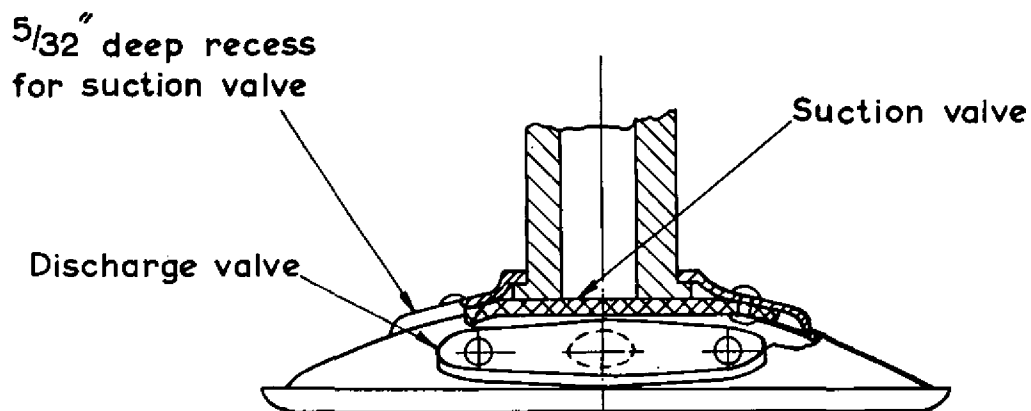

RUBBER VALVE
2 off

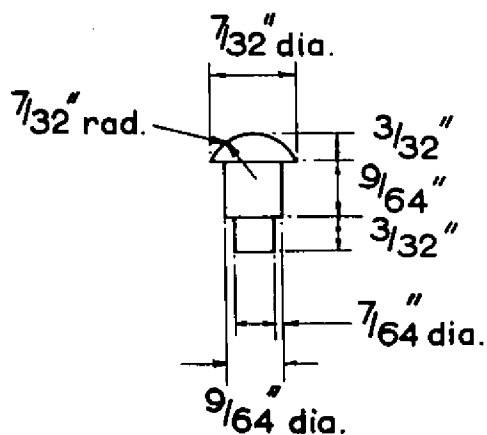

RETAINING RIVET
(BRASS) 4 off

FIG. 1. RUBBER VALVES FOR PUMP (FLANGE TYPE)

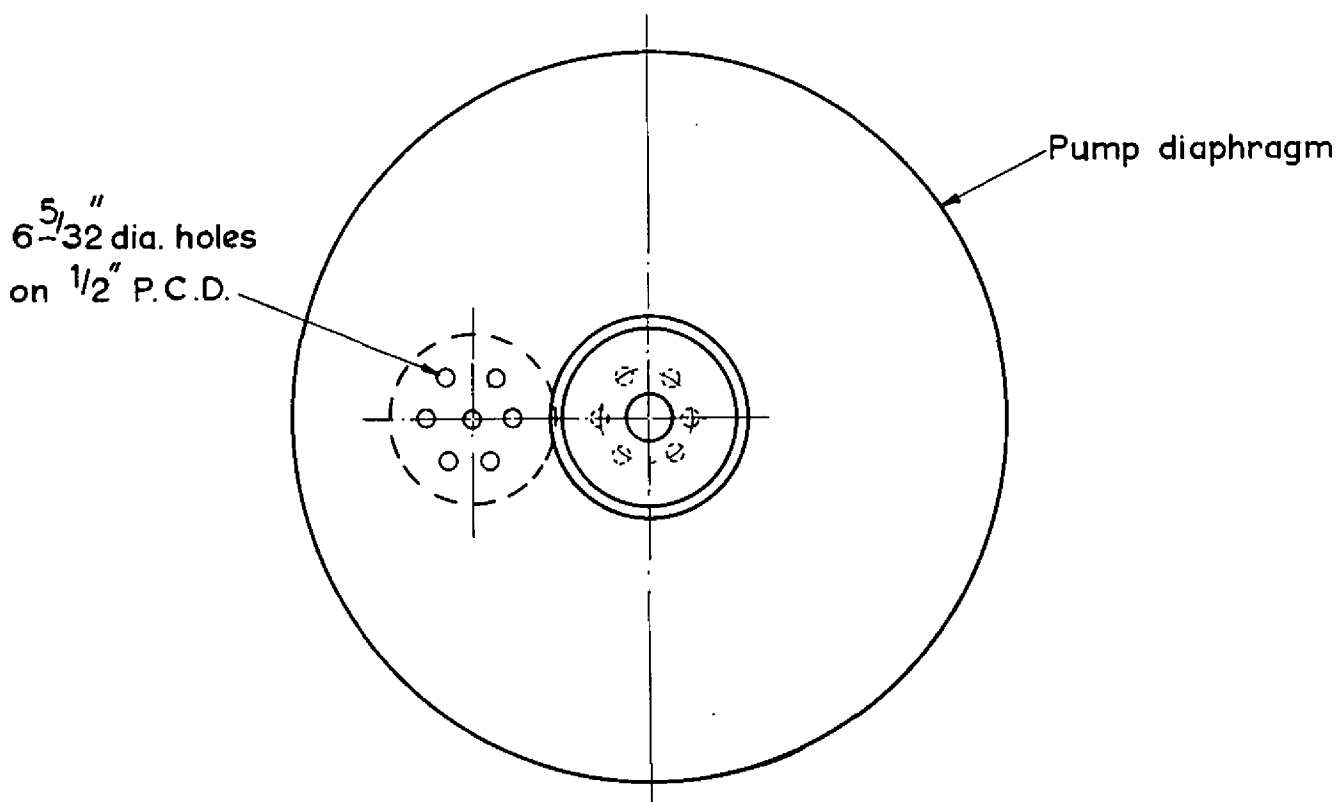

UNDERSIDE OF DIAPHRAGM

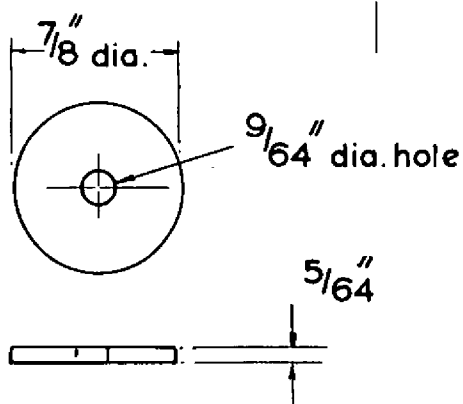
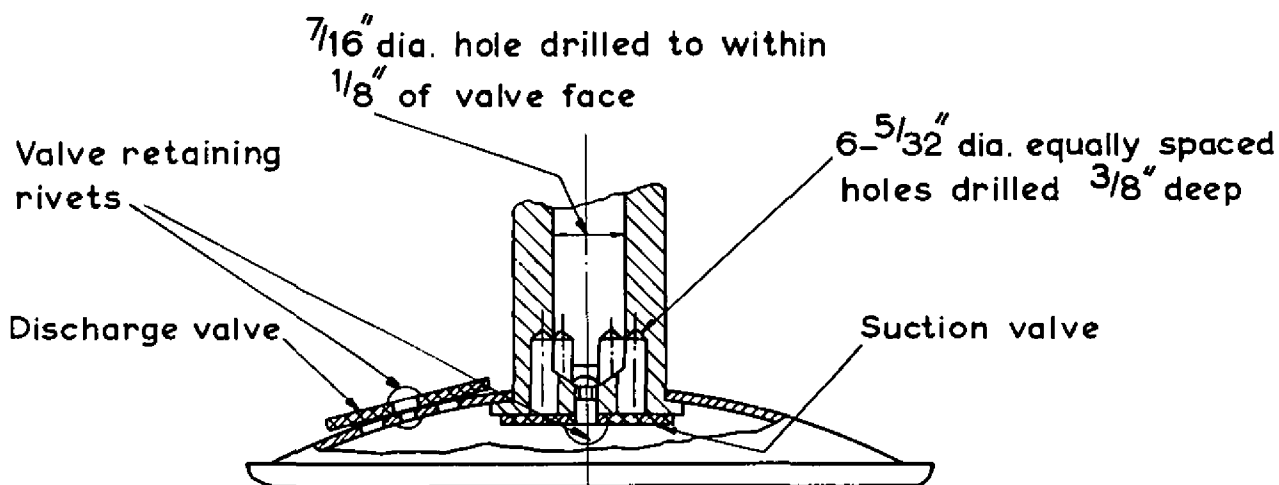

RUBBER VALVE
2 off

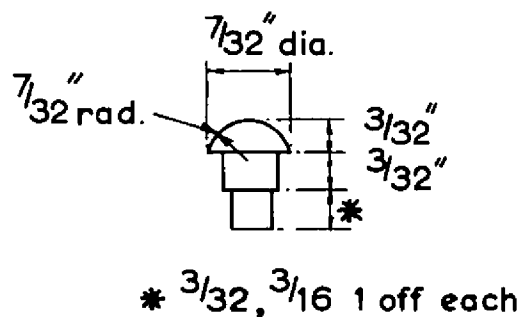

RETAINING RIVETS
(BRASS) 2 off

FIG. 2. RUBBER VALVES FOR PUMP (DISC TYPE)