

F.R. Note No. 464

DEPARTMENT OF SCIENTIFIC AND INDUSTRIAL RESEARCH AND FIRE OFFICES' COMMITTEE
JOINT FIRE RESEARCH ORGANIZATION

This report has not been published and should be considered as confidential advance information. No reference should be made to it in any publication without the written consent of the Director, Fire Research Station, Boreham Wood, Herts. (Telephone: ELS 1341 and 1797).

THE TESTING OF INDUSTRIAL DUSTS FOR EXPLOSIBILITY

by

P. S. Tonkin and Monica M. Raftery

Summary

This note describes the apparatus and procedure for testing suspensions of industrial dusts in air for explosibility. The explosibility is expressed in terms of a standard classification which is also given.

The testing of dusts is carried out on behalf of the Factory Inspectorate of the Ministry of Labour, and had previously been undertaken at the Safety in Mines Research Establishment, Buxton.

June 1961

Fire Research Station,
Boreham Wood,
Herts.

THE TESTING OF INDUSTRIAL DUSTS FOR EXPLOSIBILITY

by

P. S. Tonkin and Monica M. Raftery

INTRODUCTION

The first apparatus used for testing industrial dusts for explosibility at the Safety in Mines Research Establishment, Buxton, was designed for the measurement of the relative explosibilities of coal dusts⁽¹⁾. The testing of industrial dusts for explosibility, done on behalf of the Factory Inspectorate of the Ministry of Labour, has been carried out since 1913 in similar apparatus. Since the review by Brown⁽¹⁾ there have been various modifications and additions to the original apparatus as well as the introduction of a further test⁽²⁾, so that at present there are four main test apparatus all of which may need to be used for adequate classification of the dust for explosibility. The Factory Inspectorate use the results and classification in recommending safety measures for industrial plant handling explosible dusts.

The testing of dusts for explosibility has now been transferred to the Joint Fire Research Organization from the Safety in Mines Research Establishment and the test apparatus has been constructed at Boreham Wood. This report gives details of the design of the apparatus, the method of use and a comparison of the results obtained on identical dusts at Boreham Wood and Buxton.

TEST METHODS

Four tests are used to determine the flammability of the dust. The four forms of test apparatus are illustrated in Plates 1 - 4. In all the tests the dust is dispersed by an air blast over an igniting source in the test apparatus. A summary of the main features of the different apparatus is given in Table 1.

Table 1

Types of test apparatus

Apparatus	Direction of dispersion of dust	Igniting source	Illustration
Horizontal tube (Wheeler's Test No. 1 modified)	Horizontal	Heated platinum wire coil (Small igniting source)	Plate 1
Inflamator (Vertical tube apparatus)	Vertically downwards	Electrically heated wire coil or electric spark (Small igniting source)	Plate 2
Hartmann type (Vertical tube apparatus)	Vertically upwards	Electric spark or electrically heated wire coil (Small igniting source)	Plate 3
Furnace (Wheeler's Test No. 2 modified)	Vertically downwards	Heated wall of furnace (Large igniting source)	Plate 4

It is an essential feature of any test apparatus that it should be capable of giving as good a dispersion as possible of the dust at the igniting source. The dusts which are tested have a very wide range of dispersibility and it is therefore necessary that the conditions for dispersing the dust can be varied in all the tests. In all four tests it is therefore possible to vary the blast which causes the dust to disperse, and the mass of the dust which is subjected to this blast.

In the inflammator and in the Hartmann type apparatus the position relative to the ignition source where the dispersed dust enters the tube can also be varied. In the horizontal tube and furnace tests the temperature of the igniting source may be varied up to 1300°C and 1000°C respectively. Appendices 1, 2, 3 and 4 describe the apparatus in detail and include modifications and additions introduced since the review by Brown(1)

It is sometimes also desirable to obtain an estimate of the amount of inert dust in a sample. This is obtained by examination under a microscope or by combustion in a furnace.

GENERAL PROCEDURE

Before testing a dust sample its toxicity and that of its combustion products is considered and if the material has toxic properties appropriate safety precautions are taken.

Preparation of dust samples

Whenever possible the dust, as received, is tested directly. If, however, the "as received" dust is not readily dispersable because of high moisture content, its dispersability may be improved by drying the sample either in a desiccator or in a liquid jacketed oven at 104°C. If the dust sample contains large particles, which would block the dust holders in the 'furnace' or 'inflammator' tests, or would not be readily dispersed by the air blast in the other tests, the sample may be sieved through an 18 mesh BS sieve to remove the coarse particles which are then discarded and the remainder of the sample is submitted to the various tests.

If ignition does not occur with the dust sample from which the coarser particles have been removed or with the 'as received' dust, even after drying, or if it ignites only in the furnace test, the sample may be sieved through various mesh sizes down to 240 BS and the test procedure repeated on the sieved and dried fractions.

Sequence of tests

Usually the flammability of the dust is tested in the four forms of apparatus in the following sequence:

- 1. Horizontal tube.
- 2. Inflammator.
- 3. Hartmann type.
- 4. Furnace.

Since the formation of explosible dust clouds depends to some extent on the direction of dispersion of dusts and since ignition of such dust clouds may depend upon the type of small igniting source present, non-ignition in the horizontal tube apparatus is followed by testing in the inflammator and if there is no ignition in that apparatus testing is carried out in the Hartmann type apparatus.

Metal dusts are not tested in the horizontal tube as they may damage the platinum-igniting coil. In all four forms of apparatus an attempt is made to obtain ignition of the dust cloud within the whole range of conditions of dust dispersion, and temperature of the igniting source available in the apparatus. If ignition is obtained in either the horizontal tube or the furnace test, then the lowest temperature at which the dust will ignite is also determined to within 10°C. Since the furnace test gives lower temperatures for ignition of dusts than those obtained in the horizontal tube, it is often necessary to carry out the furnace test even though ignition may have occurred in one of the previous tests.

It is sometimes necessary to determine the amount of inert gas required in the atmosphere to suppress flammability of the dust. This is determined in the furnace test. Minimum explosive concentrations for dusts are occasionally determined in the Hartmann apparatus.

Detailed test procedures are given in Appendices 1, 2, 3 and 4.

CLASSIFICATION OF DUSTS

The explosibility of dusts is classified as follows: (3)

- CLASS I Dusts which ignite and propagate flame readily, the source of heat required for ignition being small.
- CLASS II Dusts which ignite readily, but require a larger source of ignition.
- CLASS III Dusts which do not ignite in the tests.

Dusts which ignite and propagate flame in the horizontal tube, inflammator or the Hartmann type apparatus either as received or after sieving and drying are placed in Class I.

Dusts which ignite and produce flame in the furnace test, but not in the other three tests, are placed in Class II.

Dusts which do not produce flame in any test, or dusts which ignite in the furnace test and produce a very small flame when the furnace temperature is 1000°C, are placed in Class III.

A classified list of the dusts that have been tested for explosibility is published at intervals (3).

TESTING THE APPARATUS

To test the new apparatus and to obtain correlation between the two laboratories, dust samples, already tested and classified at the Safety in Mines Research Establishment, were again tested and classified at Joint Fire Research Organization.

The results of these tests are shown in Table 2 and results obtained at Buxton, with the same dusts, are included for comparison.

The results given by the new apparatus are in reasonable agreement with those obtained with the apparatus at Buxton. The same classifications of explosibility were obtained with all the dust samples in both sets of apparatus.

ACKNOWLEDGMENTS

Thanks are due to Mr. B. M. O'Reilly, H. M. Inspector of Factories, and Mr. C. E. Curzon of the Safety in Mines Research Establishment, Buxton for advice and providing facilities for obtaining full details of the original apparatus, and also for supplying the dust samples for testing the apparatus.

REFERENCES

1. BROWN, K. C. Research Report No.21. Safety in Mines Research Establishment 1951.
2. ESSENHIGH, R. H. Research Report No.188. Safety in Mines Research Establishment, May 1960.
3. FACTORY INSPECTORATE. Dust Explosions in Factories. Form 830 (Revised) 1959, H. M. Stationery Office.

TABLE 2

Comparison of results obtained from dust testing carried out at the Safety
in Mines Research Establishment, Buxton, and the Joint Fire Research Organization

Dust sample	Minimum coil temperature for ignition °C Test 1		Minimum furnace temperature for ignition °C Test 2		Inflamator test	Hartmann type test	Classification	
	J.F.R.O.	S.M.R.E.	J.F.R.O.	S.M.R.E.	J.F.R.O.	J.F.R.O.	J.F.R.O.	S.M.R.E.
Cork	1040	950	470	470	Not tested	Not tested	I	I
Cocoa and condensed milk	930	880	385	430	Not tested	Not tested	I	I
Liquorice dust	1050	Partial ignition only	485	500	Not tested	Not tested	I	I
Magnesium Oxide	No ignition	No ignition	No ignition	No ignition	No ignition	No ignition	III	III
Carbon fines sulphur contaminated	No ignition	No ignition	560	620 (sieved and dried)	No ignition	No ignition	II	II
Crushed nutshell	950	960	455	420	Not tested	Not tested	I	I
Wood dust	1005	1160	470	430	Not tested	Not tested	I	I
Aluminium dust (Coarse)	Not tested	Not tested	No ignition	No ignition	No ignition (as received) No ignition (sieved)	No ignition (as received) Ignition (sieved)	I	I
Magnesium dust	Not tested	Not tested	600	730	Ignition	Not tested	I	I
Carbon dust with aluminium	Not tested	Not tested	530	570	No ignition	No ignition	II	II
Stramonium	No ignition	No ignition	400	460	Ignition	Not tested	I	I
Bronze dust	Not tested	Not tested	No ignition	No ignition	No ignition	No ignition	III	III
Bronze dust	Not tested	Not tested	980	1000 (850 sieved)	No ignition	No ignition	II	II
Bronze dust	Not tested	Not tested	440	450	Ignition	No ignition	I	I

APPENDIX I

HORIZONTAL TUBE (Modification of Wheeler's Test No. 1)

Apparatus

A sketch of the apparatus is shown in Fig. 1. The 3 inch internal diameter, horizontal, borosilicate glass, combustion tube (A. Fig. 1) is in two parts. The left hand part is 18 in long with a one inch diameter hole in its wall, situated 5 in from one end and the right hand part is 36 in long. Both parts are held in adjustable iron supports and butt on to opposite sides of the asbestos wood holder (B) for the ignition coil. The two parts of the tube are held tightly against the asbestos wood by two tie rods acting on brass collars which are clamped externally to the appropriate ends of the tube parts. The butt joints are sealed with soft jointing material.

Fig. 2 shows the ignition coil unit. The igniter consists of a platinum wire coil 0.7 in long made from an 18 in length of 32 S.W.G. platinum. The coil is wound around the outside of the centre section of a ceramic tube 6 in long approximately 0.04 in bore and 0.1 in outside diameter. The turns of the coil are spaced to give even temperature along its length. The ends of the coil are connected to the output side of a variable transformer which allows the coil to be heated to 1300°C. The bore of the ceramic tube carries a thermocouple with its butt welded junction at the centre of the tube. The couple is made of pure platinum, 13 per cent rhodium-platinum wire, 26 S.W.G. The ends of this thermocouple are connected, with compensating leads, to a millivoltmeter which indicates the temperature of the ignition coil directly. The igniter is fixed in a groove $\frac{3}{16}$ inch deep in the asbestos wood holder. The asbestos wood has a 3 in diameter hole in the centre and when the apparatus is assembled the ignition coil lies diametrically across the combustion tube in the horizontal plane.

Dispersion of dust around the coil is effected by a blast of air which may be varied in quantity as required. The air is metered (C. Fig. 1) at the required flow rate and then diverted for 2 seconds on to the dust in the combustion tube by the operation of a three-way solenoid valve (D). The valve mechanism is operated by a relay controlled by a cam on the shafting of an electric clock motor.

Test procedure

About 2 g of the dust sample are placed in a conical heap in the combustion tube, through the one inch diameter hole in the tube wall. The hole is then sealed with a cork and the ignition coil is heated to 1300°C. The heap of dust is then dispersed in the direction of the coil by the air flow directed at its base. Observation is made as to whether or not propagation of flame takes place. If the dust cloud ignites, the temperature of the ignition coil is reduced and the amount of dust varied until the lowest two temperatures are obtained differing by 10°C such that the dust ignites at the higher temperature only. The test is carried out three times with the coil at the temperature at which no ignition takes place. If the dust cloud does not ignite with a coil temperature of 1300°C the quantity of dust is increased and further attempts made to obtain ignition. This procedure is continued until ignition occurs or until no further increase is obtained in the amount of dust dispersed as judged visually.

APPENDIX 2

INFLAMMATOR

Apparatus

The combustion tube (A, Fig. 3) is of borosilicate glass, 3 inches internal diameter and 40 in long. It is open at the top and closed at the bottom with a loosely fitting rubber bung. The tube has four side arms one inch internal diameter, 2.5 in long, at intervals of 10 in along the right hand side and one side arm of like dimensions of the left hand side forming a cross 5 in from the bottom of the tube. The ignition coil holder or electrode holders fit into the bottom side arms and a brass dust holder (B) fits into any of the side arms above the igniting source. The dust is blown from the holder with a blast of air from an air reservoir (C) of 28 in³ capacity. The dispersion of the dust cloud is improved by the deflector plate (E). To allow filling of the reservoir to the required pressure and the quick release of the air, a spring loaded, clamp assembly (D) operates on the rubber tubing between the air reservoir and the dust holder.

The source of ignition may be either a hot coil or an electric spark. The coil (F) is $7\frac{1}{2}$ turns of 20 S.W.G. electrical resistance wire, each turn being $\frac{5}{16}$ inch internal diameter, and is heated by a 10 volts 20 amperes A.C. supply. The electric spark is generated from an induction coil with a Ruhmkorff commutator and the energy applied to its primary circuit is about 70 watts.

Procedure

About 2 g of the dust to be tested are placed in the holder (B, Fig. 3) which is then closed and the air pressure in the reservoir is raised to a value sufficient to blow all the dust out of the holder. According to which source of ignition is used, either the wire coil is heated to about 1300°C or continuous sparking between the electrodes is started. The air is then released from the reservoir by operating the clamp and observation is made as to whether or not flame propagates in the dust cloud as the latter falls past the igniter. If no ignition occurs after three attempts, the quantity of dust, the air pressure and the position of the dust holder are varied in turn in further attempts.

The actual temperature of the igniting coil is not measured in this test.

APPENDIX 3

HARTMANN TYPE APPARATUS

Apparatus

Figure 4 shows the apparatus diagrammatically. (A. Fig. 4) is a brass block, the top of which is a dispersion cup and the air for dispersing the dust is delivered through a brass tube (B) 0.375 inch internal diameter in the centre of the cup. At the end of the tube is a mushroom-like air deflector (C). Fitting to the top of the cup, by means of a brass adaptor, is a perspex combustion tube (D) 2.5 inches internal diameter and 12 in long. The tube has five pairs of diametrically opposed brass electrode holders, fitted into its wall. A pair of brass electrodes is screwed through the appropriate holders and a spark gap of about 0.25 in is used. Fitting over the top of the perspex tube is a brass locking ring (E), 2.5 inches internal diameter, which, in certain tests, holds a filter paper diaphragm in position. The combustion tube assembly is fixed to the dispersion cup by clamping bolts and the dispersion cup is fixed to the wooden base (F).

The apparatus used for providing the air blast for dust dispersion is similar to that used in the inflammator, and the apparatus used for producing the induction spark is the same as that used for the inflammator test.

The test apparatus may be modified to enable dust to be dispersed upwards over a different igniting source, the source being an electrically heated wire coil. The perspex tube is replaced by a borosilicate glass tube which is of larger outside diameter. Consequently, the dispersion cup is modified by attaching a brass annulus, (A. Fig. 5) outside diameter 4 inches, on which the glass tube (B. Fig. 5) is clamped. This tube has a side arm, 5 in from one end, to accommodate the igniting coil holder, and may be inverted, thus allowing the igniting coil to be used at two different heights above the dispersion cup.

Procedure

About 2 grams of dust are placed in the dispersion cup, the combustion tube is fitted to the top of the cup and the clamp, acting on the air line, is closed. The air pressure in the reservoir is raised to a value known to give good dust dispersion, as judged visually from the previous dispersion tests with the same dust, and the igniting source is energised. Upon releasing the clamp the air disperses the dust upwards through the igniting source and observation is made as to whether or not flame propagates in the dust cloud.

When propagation does not occur with one set of conditions the test is repeated twice. If there is still no flame propagation the quantity of dust, the air pressure and the position of the igniter are varied in turn. The above procedure is used with both forms of the apparatus.

The apparatus is also used to determine minimum explosive concentrations of dusts. A weighed amount of dust, known to explode, is placed in the dispersion cup and a filter paper diaphragm, with a $\frac{1}{16}$ in diameter hole in the centre is held over the top of the combustion tube by the brass locking ring. The testing procedure is the same as described above but the criterion for indicating explosion is propagation of flame, sufficient to fill the combustion tube, accompanied by the bursting of the filter paper diaphragm. When this occurs the quantity of dust is reduced and testing continued until no explosion occurs. The weight of the smallest quantity of dust with which explosion occurs is divided by the volume of the tube to give the value of the minimum explosive concentration.

APPENDIX 4

FURNACE (Wheeler's Test No. 2 modified)

Apparatus

The apparatus is shown diagrammatically in Fig. 6 and consists of an air reservoir (A) approximately 28 in³ capacity, a quick release, spring loaded, clamp (B), dust holder (C) and furnace (D). A pyrex glass adaptor (E) connects the holder to the furnace. The furnace tube (F) is of vitreosil 8½ in long, 17/16 inches internal diameter, and the heating element is of 20 S.W.G. electrical resistance wire (iron-chromium-aluminium type) wound in external grooves which are spaced to give even temperature throughout the tube length. The furnace temperature is controlled thermostatically with a temperature controller which is governed by a 19 S.W.G. chromel/alumel thermocouple cemented into the wall of the furnace tube at its midpoint. The entire heating element is covered with the cement and lagged with asbestos tape. The tube is fitted into a furnace box, internal dimensions 6 in x 6 in x 9 in, made of asbestos wood and filled with Kieselguhr. The furnace box is held in a thin sheet metal casing and is supported vertically on four legs.

Test procedure

In cases where no ignition occurs in the previous tests the furnace temperature is raised to 1000°C, otherwise a lower temperature may be used. About 0.2g of dust is placed in the dust holder which is then closed. The spring loaded clamp is applied to the air line and the pressure in the reservoir raised to about 5 p.s.i.g. The spring loaded clamp is released and the dust is blown through the furnace tube. Observation is made as to whether or not flame appears at the bottom of the furnace. When ignition takes place the furnace temperature is lowered until two temperatures, differing by 10°C are obtained, such that ignition takes place at the higher temperature only. When ignition does not occur in three consecutive tests, at a particular temperature, the quantity of dust dispersed and the air pressure are varied and the test procedure is repeated. In this way the lowest furnace tube temperature at which ignition occurs is determined.

The apparatus may be modified and used to determine ignition temperatures of dust clouds in atmospheres other than air. The modification is effected by fitting a pyrex glass adapter with a side arm (A. Fig. 7), between the dust holder and the top of the furnace and fixing a borosilicate glass tube (B), 3 inches internal diameter and 6 in long, directly under the furnace so that the same atmosphere is maintained inside it as in the furnace tube itself. During testing the whole of the apparatus is filled with the required gas mixture. While the reservoir is being filled to the required pressure, and throughout the testing period, the furnace tube and the borosilicate glass tube below it are kept filled by passing the gas mixture through the side arm of the pyrex glass adapter. Otherwise the test procedure is similar to that with air.

Not to scale

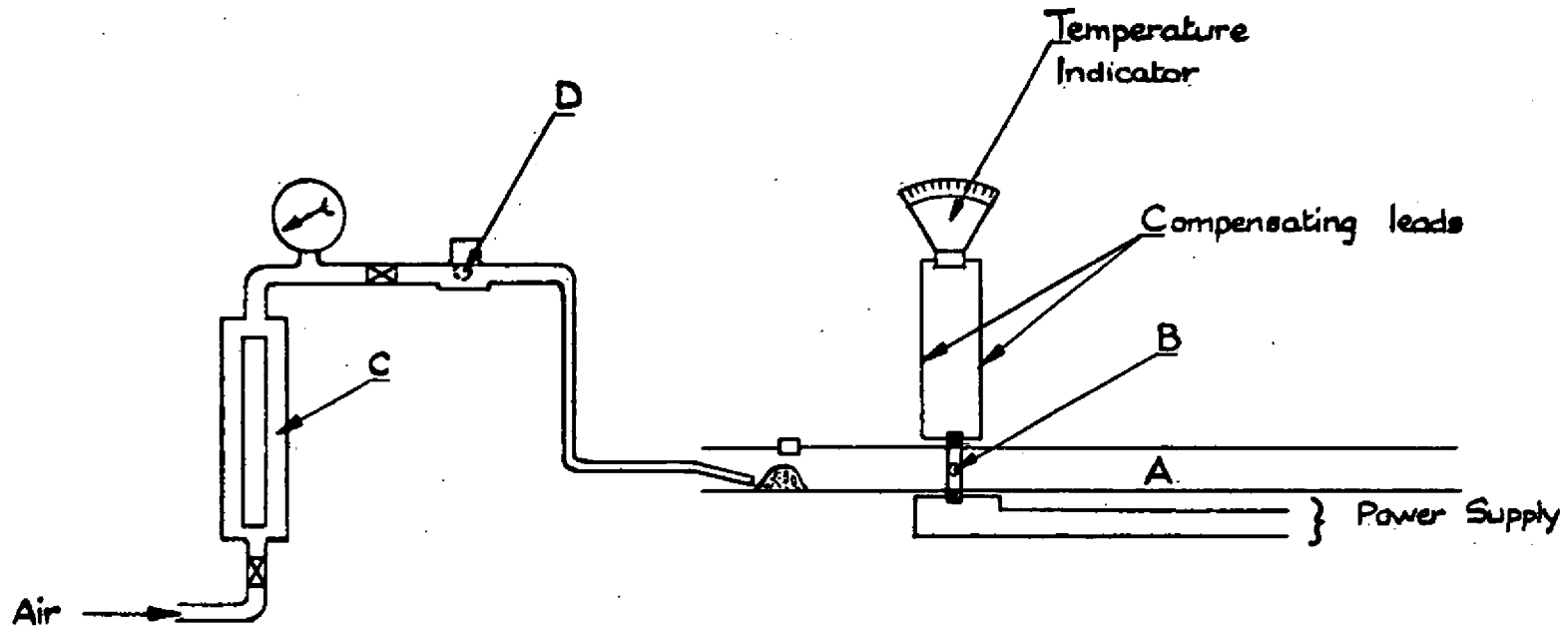

FIG. I. HORIZONTAL TUBE APPARATUS.

Not to scale

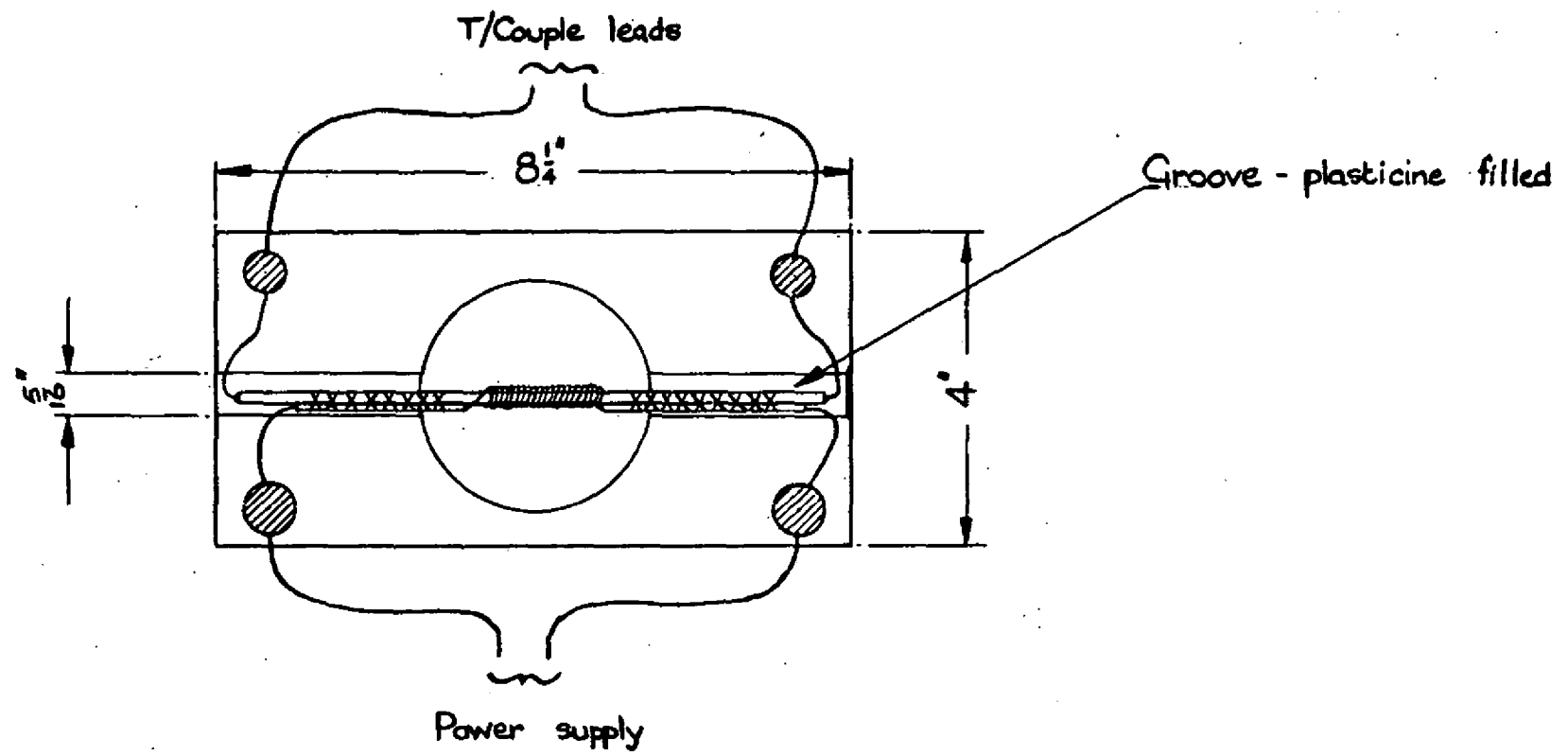
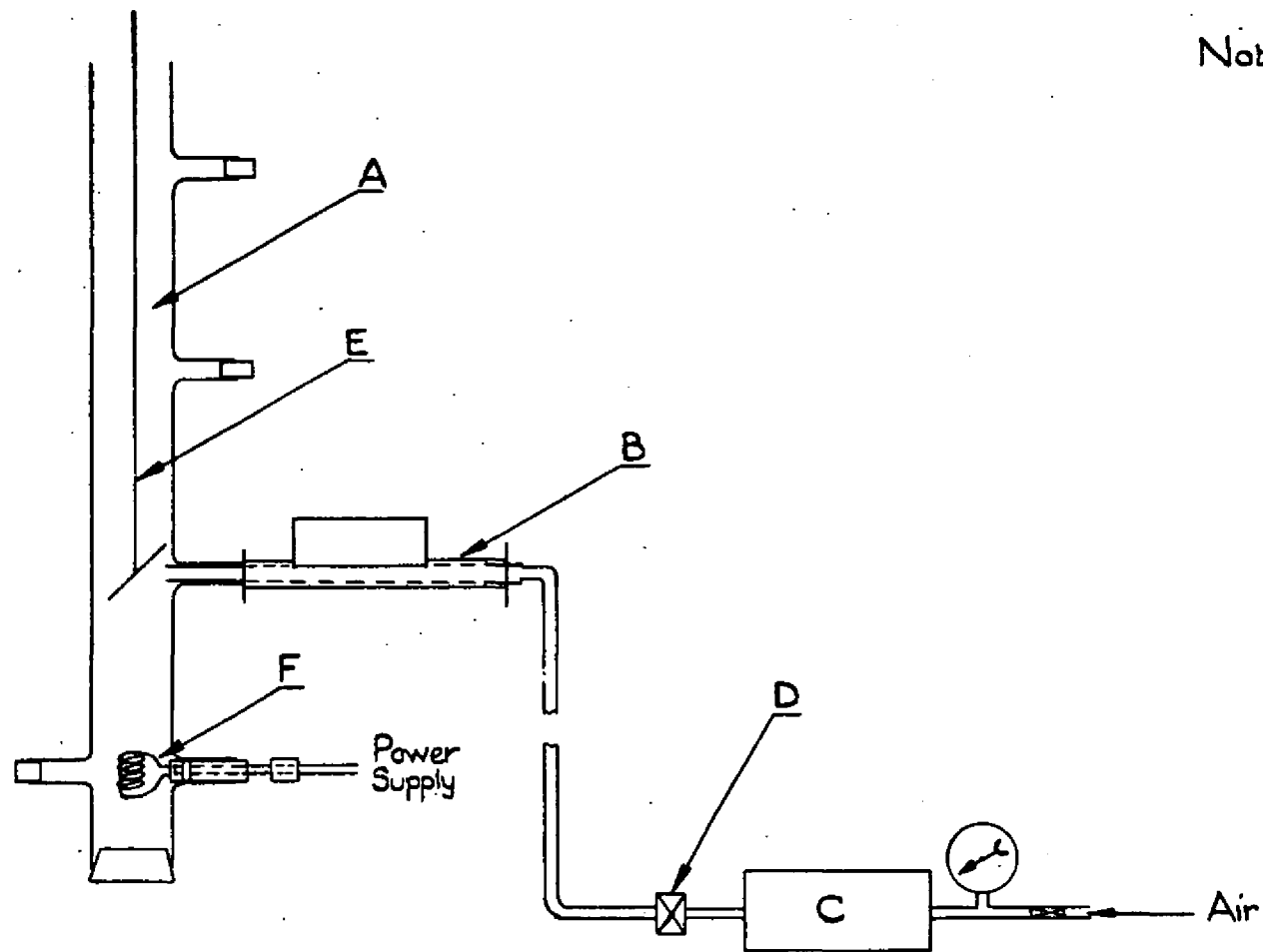
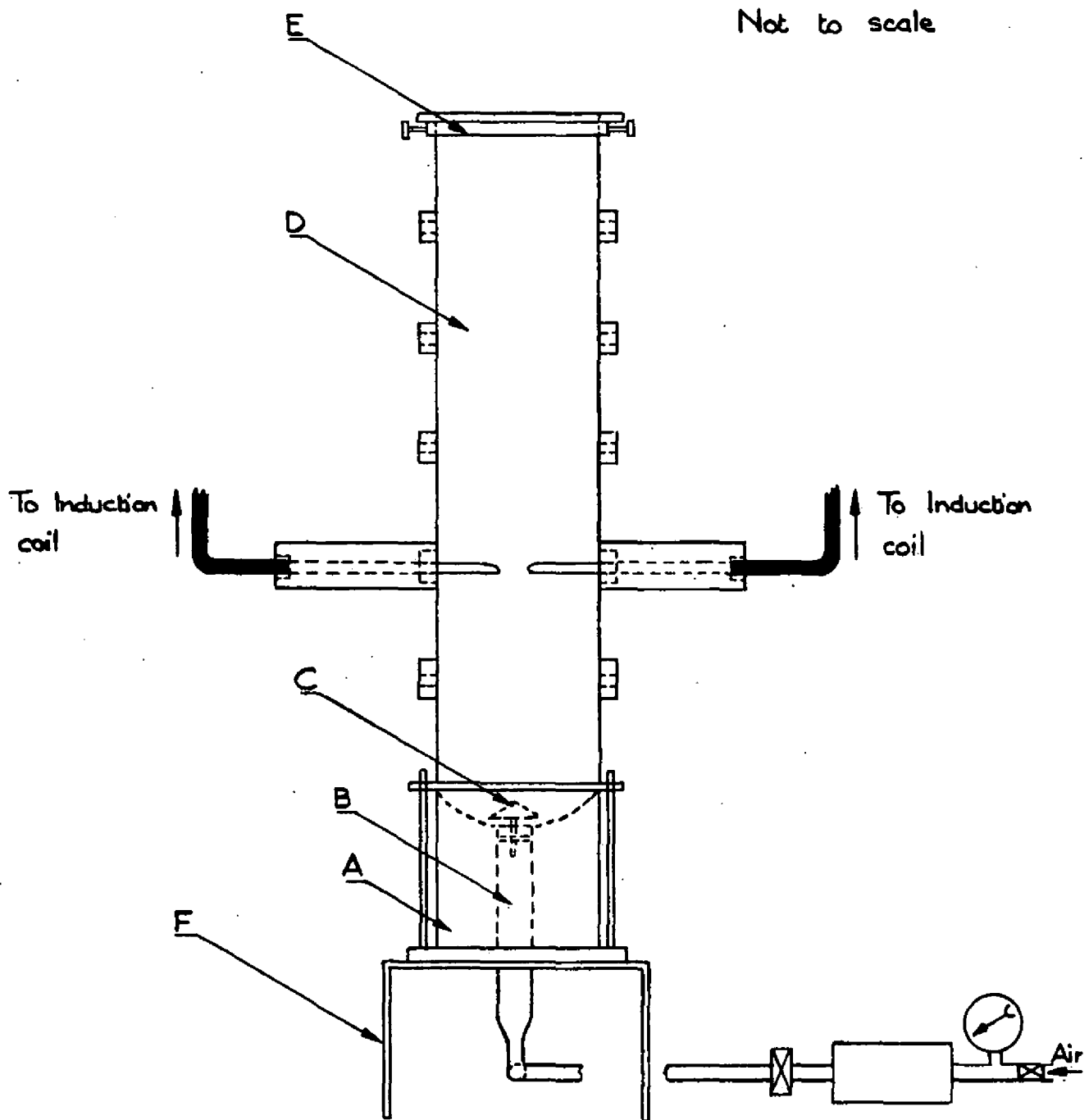

FIG. 2. IGNITING COIL AND HOLDER FOR THE HORIZONTAL TUBE APPARATUS



Not to scale

FIG. 3. APPARATUS FOR INFLAMMATOR TEST



R 46

FIG. 4. HARTMANN TYPE APPARATUS

Not to scale

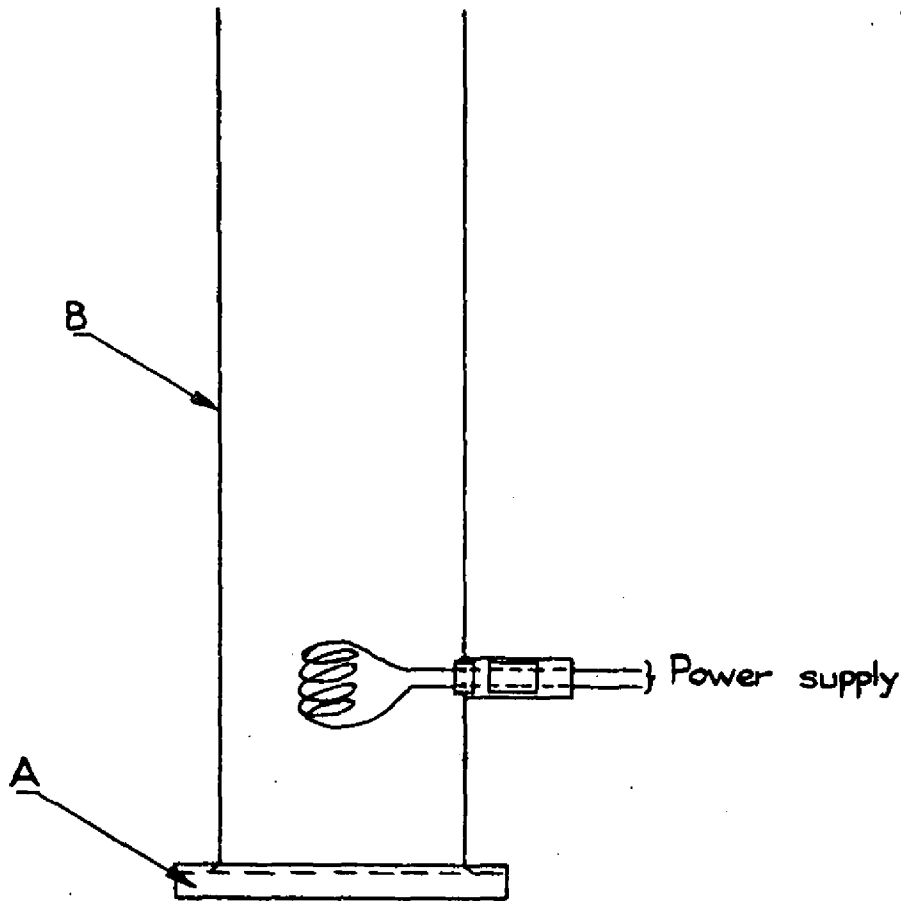

FIG. 5. PYREX TUBE AND IGNITING COIL FOR MODIFICATION TO HARTMANN TYPE APPARATUS

Not to scale

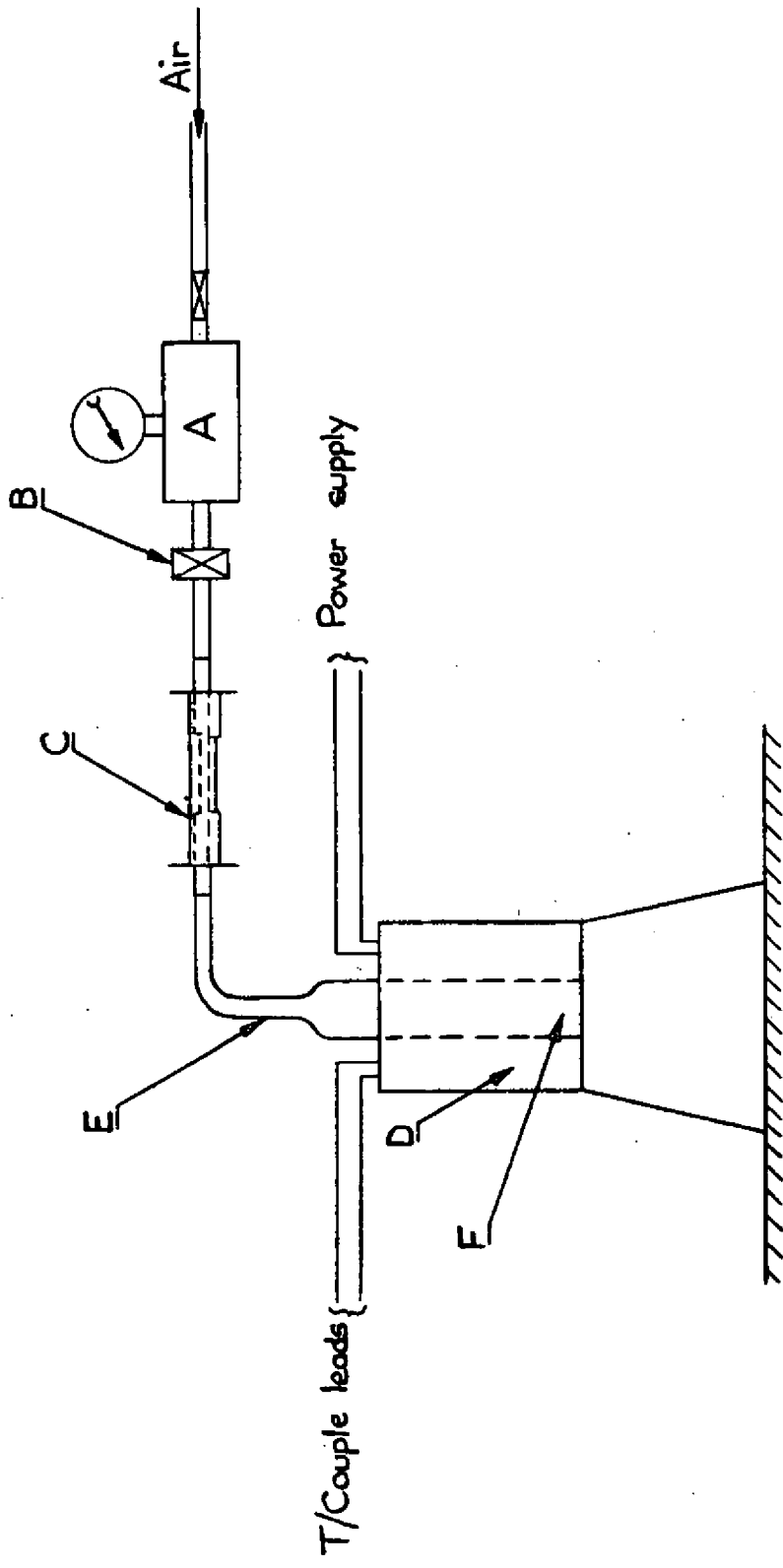

FIG. 6. FURNACE APPARATUS

Not to scale

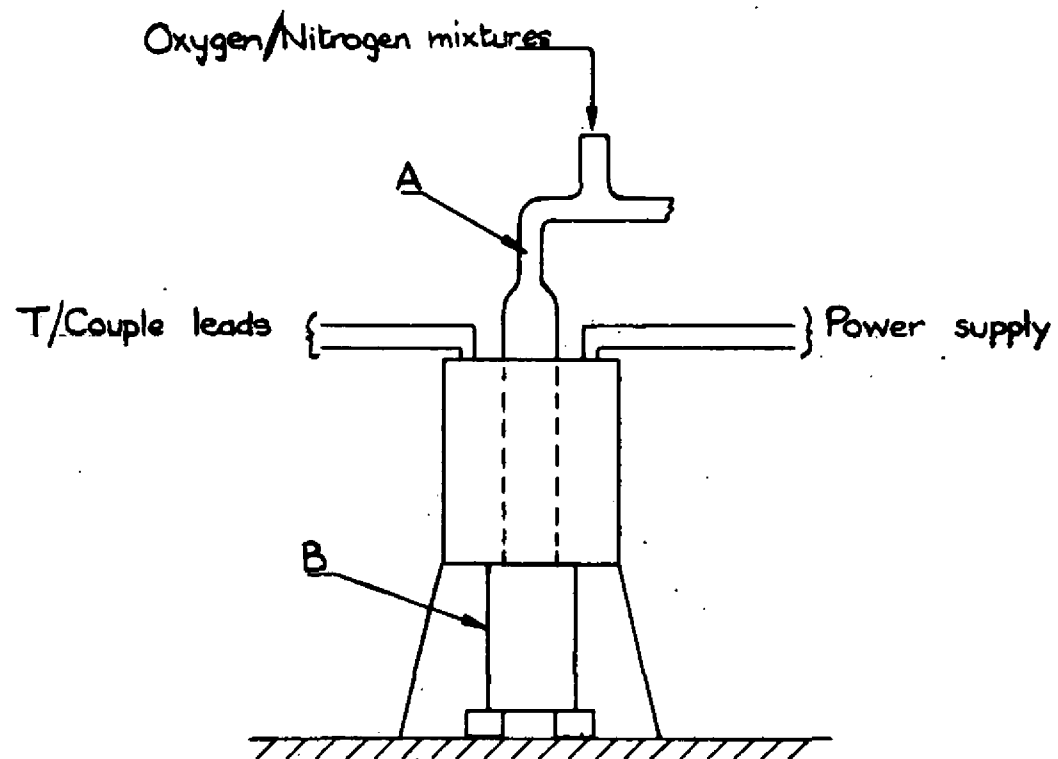
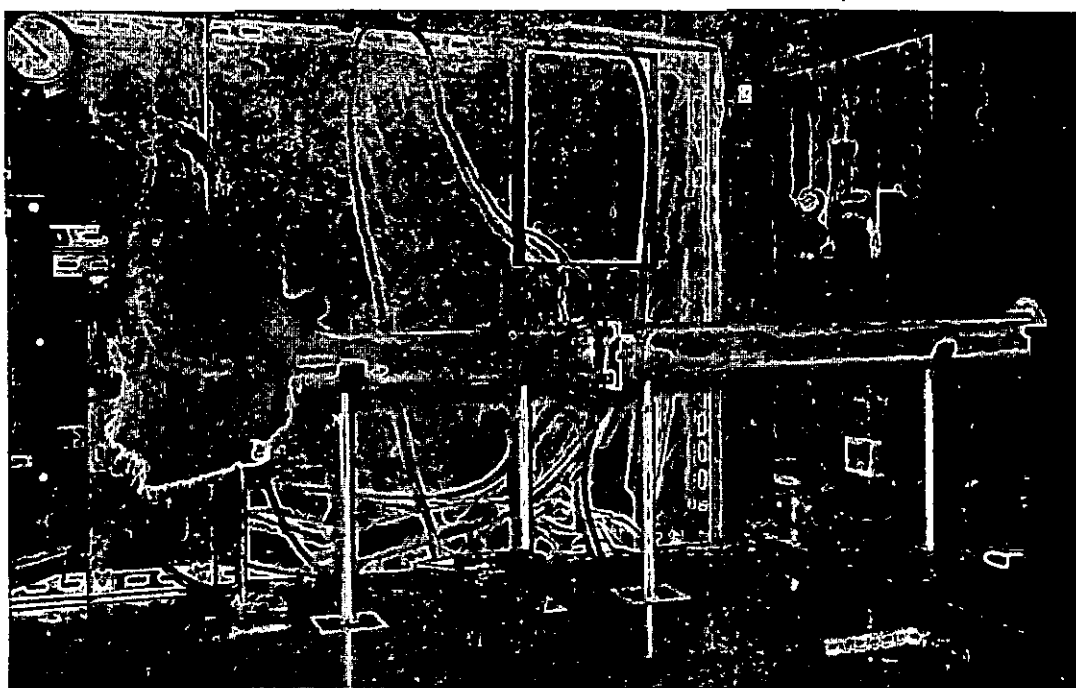
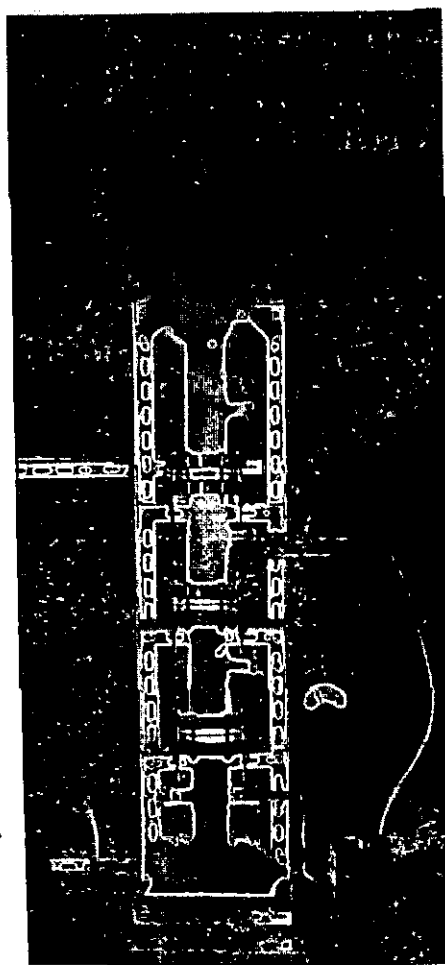

FIG. 7. MODIFIED FURNACE APPARATUS FOR USE WITH ATMOSPHERES OTHER THAN AIR



Ignition of cork dust

PLATE 1. HORIZONTAL TUBE



Ignition of aluminium
dust

PLATE 2. INFLAMMATOR

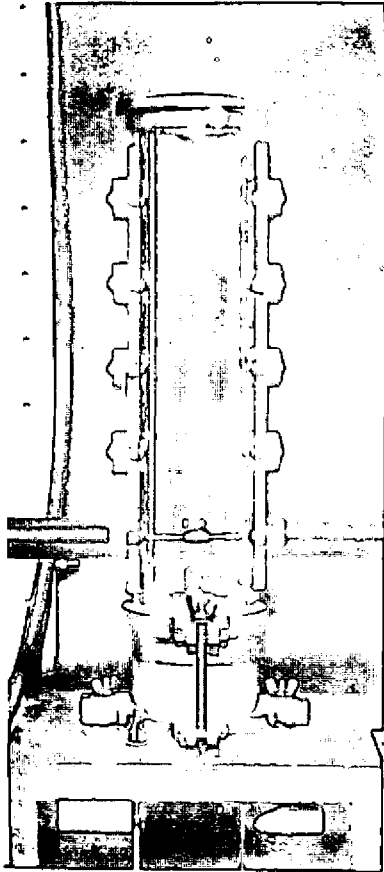

(a) Showing continuous electric spark

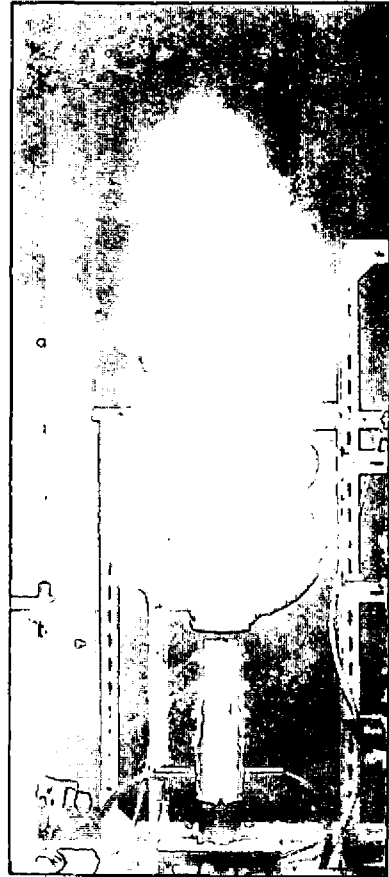

(b) Ignition of aluminium dust

PLATE 3. THE HARTMANN TYPE APPARATUS

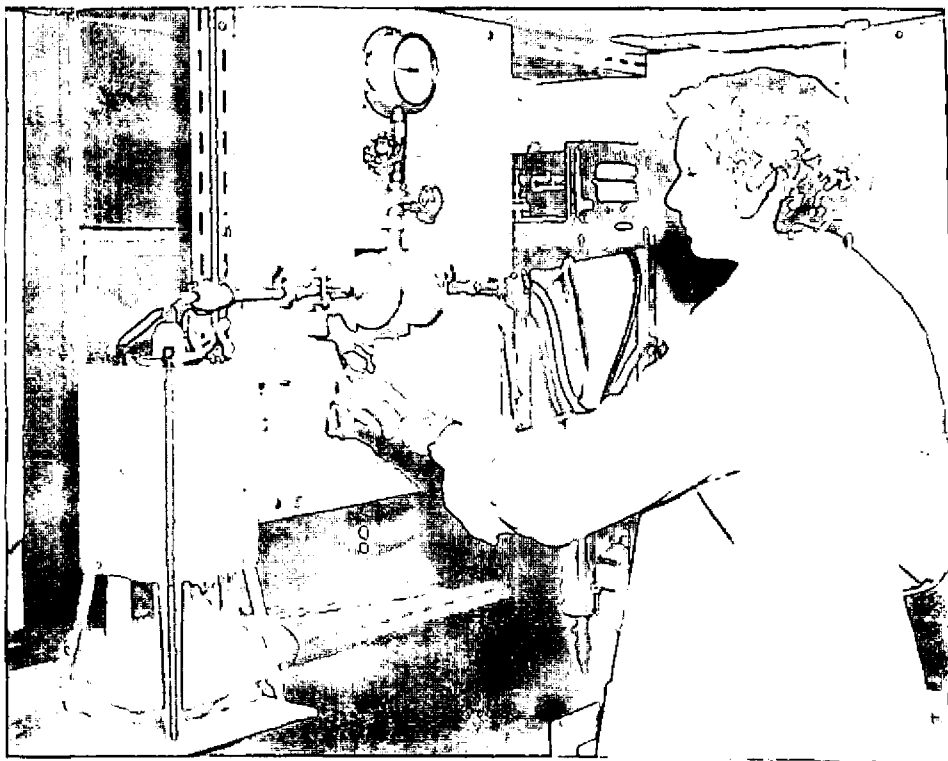

Ignition of cork dust

PLATE 4. FURNACE