

DEPARTMENT OF SCIENTIFIC AND INDUSTRIAL RESEARCH
AND FIRE OFFICES' COMMITTEE
JOINT FIRE RESEARCH ORGANIZATION

RESEARCH INTO FIRE PROTECTION

by

D. I. Lawson

SUMMARY

The number of outbreaks of fire has risen rapidly in recent years and it is suggested that this is a consequence of the expanding national economy. Research is being carried out to limit the spread of fire and this involves finding out more about the fundamentals of fires in buildings, how these develop and the kind of fire conditions to which structures are likely to be subjected. The paper discusses early warning devices and new methods of fire extinction. Finally, it is suggested that more should be known about the economics of structural fire protection as the area of uncertainty in this expenditure is probably about twice the current fire loss.

November, 1963.

RESEARCH INTO FIRE PROTECTION

by

D. I. Lawson

There are three main objectives in fire protection, rather like lines of defence:

1. To eliminate all outbreaks of fire
2. To ensure that all outbreaks are localized
3. To ensure that the brigades are able to extinguish all outbreaks quickly and efficiently, even the few that become large fires.

The Joint Fire Research Organization was formed in 1946 to carry out research into fire protection as a joint venture between government and insurance with the object of reducing the loss of life and property in fire. This afternoon I should like to tell you about some aspects of its current work.

ELIMINATING OUTBREAKS OF FIRE

No one would expect to succeed in eliminating all fires but this in no way detracts from the importance of the objective. In spite of all efforts our statistical records show that the number of fires attended by the brigades, excluding trivial chimney fires, has risen from 72 000 in 1950 to 167 000 in 1962. About half of these occur out-of-doors and their number depends markedly on the weather, the warm dry summers of 1947, 1949, 1952, 1955 and above all, 1959, showing pronounced peaks.

Fires in buildings are more important than those in the open, by virtue of both the greater potential risk to life and the loss of the building including the goods stored in it. The number of fires in buildings attended by the local authority brigades has risen steadily from 44 000 in 1950 to 73 500 in 1962. It is unlikely that this is due to an increasing willingness to call the

fire brigade because the proportion of fires found to have been extinguished on arrival has not varied during these years.

Fires are produced as a result of human activity; this may be measured by the Gross National Product, a term embracing the value of goods, buildings and fuels produced. The number of fire calls may be compared with the Gross National Product or rather the Product normalized to take into account the changing value of the pound. The number of fires per annum rises more rapidly than the normalized Gross National Product (Fig. 1) which may be explained by the fact that some goods are consumed as they are produced while others are durable and accumulate over a number of years.

There is no evidence to suggest that over the last decade new hazards have arisen; generally speaking, the causes are the same and about three fires out of every four are due to a failure to apply information already known. Fires due to the usage of fuels, cigarette smoking and children with matches figure prominently. It is difficult to believe that the very rapid increase in the number of fires in the period 1950 to 1962 is a reflection of a change in our national behaviour and yet recently the number of fires attributed to smoking materials, electricity and gas has risen more rapidly than our consumption of these products. It is likely that the increase in the production of both igniting sources and flammable materials explains the rapid upward swing in the fire curve; certainly this seems to be true for fires attributed to smoking materials. Whatever the explanation, the conclusion is the same, that our awareness of the hazards of fire is not matching our increasing production.

It seems that the growth in the number of fires is influenced largely by the increasing responsibilities placed on the community by the expanding national economy. It is too facile to charge the public with increasing carelessness. The production of a favourable public response to the prevention of fire ought to be

studied. A failure to respond may be due to a genuine lack of knowledge; this could be found by sample surveys so that propaganda could be directed to the areas of ignorance. Of course, the mere possession of knowledge will not influence all individuals so it will also be necessary to measure the influence of propaganda on the behaviour of sample populations with a view to devising more effective ways of conveying fire prevention information.

FATALITIES

Every year approximately 600 - 700 people lose their lives due to burning accidents, the numbers showing no significant trend with time. The same is true for deaths in conflagrations which account for just over 100 of these fatalities. However, the number of deaths due to clothing becoming ignited by gas or electric fires has shown a downward trend with time (Fig. 2). This must be due to the influence of the Heating Appliances (Fireguards) Act, 1952, which requires gas, electric and oil-burning appliances to be fitted with fireguards before sale, rather than to the influence of newer clothing materials, for the number of deaths due to clothing becoming ignited by other sources of heat has not decreased. With electric and gas fires alone (the figures for oil fires are not available) the Act is at present responsible for the saving of 40 lives per year, compared with the 1952 figures, despite the increased usage of fuels. No similar trend is apparent for the domestic fire which does not automatically carry a fitted fireguard.

Despite considerable work carried out by the Joint Fire Research Organization to devise standards for fabrics of low flammability and of the efforts of manufacturers to produce materials conforming to these standards, deaths due to clothing becoming ignited still account for about one-half of all deaths by fire.

LOCALIZING FIRES

The prevention of outbreaks of fire is in the main a problem of human science, while that of preventing fire spread depends on the

material sciences, the results of research into the latter being applied through administration rather than through the general public. Much of our work is concerned with fires in buildings, since these are economically more important than those out-of-doors.

Modern buildings are built as a series of fire compartments, the walls, floors and columns serving as barriers to flame and heat while still continuing to perform their load-bearing functions, the aim being to confine a fire to the compartment of origin. An important part of fire research, therefore, must be the study of the growth of fire in compartments and their ability to contain fires. It would be quite impracticable to study a subject of such complexity with full-scale fires so recourse to modelling must be made. It is essential that the physical principles of the developing fire be understood before the results from models can be applied with confidence to the large compartments encountered in everyday life. All fires left to themselves have a similar history; after ignition a fire spreads initially much as it would do in the open, but later the restriction of the enclosure is felt as the air supply becomes limited. The combustion at this stage is incomplete within the compartment and flames appear from the windows. The heat radiated from the flames and the window apertures falls on nearby buildings and these become ignited if the separation is insufficient. Fire spread involves the study of ignition, size of flames, rate of burning and radiation to other buildings.

IGNITION

If cellulosic materials are heated sufficiently, the flammable gases evolved will ignite, the more rapid the rate of heating, the more rapid the ignition. In most everyday fires we are concerned with ignition at times between 1 and about 2 000 seconds. While the detailed process of ignition is very complicated, it is relatively easy to predict when a material will ignite, by making the assumption that ignition will take place when the surface has

been brought to a given temperature⁽¹⁾. This works fairly well in practice and enables a wide range of experiments to be expressed on a single curve (Fig. 3). A study of ignition is necessary to understand the spread of fire which is a continuous process bringing the unburnt material ahead of the flame front to the point of ignition. (A knowledge of ignition is also used in deciding how far buildings should be separated.)

The simple treatment just outlined is equivalent to assuming that at these rates of heating, the chemical heat generated by the material itself may be neglected. This ceases to be true for ignition periods in excess of 2 000 seconds when the analytical approach becomes much more complex and is important in studying the self-heating and storage of materials⁽²⁾.

At the other end of the scale (ignition in less than 1 second which involves a high rate of heating) ignition is likely to be determined by the mechanical behaviour of the surface under thermal shock and by the aerodynamics of the issuing combustible gases. The extreme rates of heating required for ignition in such times lie in the province of nuclear explosions.

SIZE OF FLAMES

During its early stages, a fire in a building burns as though it were in the open. The size of its flames governs the level of radiation to surrounding materials which affects the rate of spread of the fire. A flame is continually entraining air so that combustion can take place, the flame length being just sufficient for combustion to be complete. By studying the entrainment of air into flames it has been possible to predict, for a wide range of fires, their size in terms of the rate of burning and the linear dimension of the fire area⁽³⁾ (Fig. 4). The same theory is also being applied to flames from windows, treating the window aperture as the fire area and the burning compartment as a producer of gaseous fuel. A further development bringing together, in terms of

dimensionless variables, all the results for the length and vertical height of flames in winds should be important in the study of forest fires.

So far, we have been concerned with the very early stages of a fire when it can be considered as being unrestricted by any enclosure. It is within this period that detectors should operate. When the flames reach the ceiling of a compartment, the hot layer of flaming gases mixes with difficulty with the cool air beneath and consequently the flame length increases rapidly. The layer of flame at ceiling height irradiates combustible materials stored on the floor and the fire develops rapidly. This break-point in the development of a fire has been called 'flash-over' and is an important stage for it marks the division between a small and a large loss.

I have avoided mentioning one difficulty; the size of flames depends on the rate of burning but the rate of burning depends on the heat supplied to the fuel which in turn depends on the size of the flames. To make progress, the two latter factors are now being studied separately so that the points of equilibrium can be derived.

FIRES INVOLVING WHOLE COMPARTMENTS

When a fire has involved a whole compartment, the question arises as to whether it can be contained by the walls, floors and columns remaining integral. Structural damage to these is a matter more of the duration of the fire than its temperature. The duration depends on the quantity of stored fuel and its rate of burning which in turn varies with the air supply. From simple buoyancy considerations⁽⁴⁾⁽⁵⁾, the air supply depends on the area of the window openings and the square root of their dimensional height. While this is roughly true, it is not sufficiently accurate for predicting how long a structure will have to withstand a fire, for it can give errors involving a factor of two in the rate of burning and hence in the duration of the fire. This has led to a

more detailed study of steadily burning fires in model compartments in which the heat transfer from the flames to the fuel is being considered.

It is only by understanding the different kinds of fire and why they occur that it will be possible in the future to lay down rational standards for the fire performance of structural elements in buildings. It has not yet been possible to model their performance in fire so fire tests are carried out on structural elements of approximately full size in large column, wall and floor furnaces to determine whether they will withstand the action of fire while continuing to act as a barrier to flame and heat under normal load conditions.

ROOF VENTING

Although the compartmenting of buildings is the best method of preventing fire spread throughout a building, the compartments themselves have sometimes to be very large to accommodate manufacturing processes. It is therefore important to see what can be done to minimize the fire spread in a large single compartment.

A small fire can completely black out the whole of the interior of a compartment, e.g. a petrol fire of area only 20 square feet will be completely hidden in a compartment, having a volume of 250 000 cubic feet, in 5 minutes (Fig. 5); the fire can then burn unchecked. One remedy is to arrange for sections of the roof to open automatically by fusible links as soon as possible after the fire starts. This prevents the building becoming smoke-logged and helps to reduce the temperature of the load-bearing roof trusses, thereby preventing the collapse of the roof in the fire area. If the roof space is divided by screens, the hot gases from the fire fill up one section, rather like an inverted bath, and open the roof vents in that section. This has the dual function of increasing the exhausting action of the vents

and of preventing the spread of fire at roof level. Model-scale experiments have provided design data for the size and disposition of the vents and for the sub-division of the roof (6).

Recently, the value of this work has been demonstrated by a fire in the upholstery and trim store of a motor manufacturer. Due to the operation of the roof venting system, the brigade could fight the fire, 13 200 square feet in area, in clear conditions, which undoubtedly proved one of the important factors in reducing fire spread.

MULTI-STOREY BUILDINGS

A multi-storey building consists of a series of fire compartments stacked vertically. These are connected by staircases and lifts which are themselves enclosed by fire-resisting walls so that escape routes are always kept open. If a fire occurs in one storey, the built-in fire-resistance of the ceiling will prevent its spread upwards, unless the flames from a window can ignite the contents of the compartment above thus leap-frogging the built-in fire protection of the ceiling. To avoid this, depending on the occupancy, under-window panels are required to resist fire for 1, 2 or 4 hours. If the building is faced with curtain walling, brick or block walls of appropriate fire-resistance have to be provided on the floor slabs behind the curtain walling and this has been so far an onerous restriction. Recent experiments on a large-scale tower building have shown that curtain walling can be constructed to have the necessary fire-resistance provided that attention is paid to the design of the panels, to the method of fixing and to fire-stopping between adjacent storeys.

It is clearly important that in a fire, staircases should remain clear of smoke and toxic products of combustion. Experiments are now in progress to see to what extent smoke-stop doors leading on to staircases are able to perform this function. In parallel, a

statistical survey is being made on the habits of the public in using smoke-stop doors, as it is essential that they should remain closed.

So far, the rate of outbreaks of fire in multi-storey buildings has been about the same as in traditional dwellings, though the pattern of causes has differed. Fortunately, the rate of fires spreading beyond the room of origin seems to be much lower, but the consequences are potentially more serious.

SPREAD BETWEEN BUILDINGS

Buildings have to be separated to prevent rapid fire spread between them leading to a conflagration. To find the required separation it is necessary to know the radiation from a burning building and how this decreases as the distance increases, then, knowing the radiation necessary to ignite combustible materials, the required distance to prevent ignition can be found. The calculation of this distance is complicated but fortunately the fact that light travels in the same way as heat can be exploited and it is only necessary to make an optical model of the burning facade of a building and measure the light intensity (7) to work out the necessary distances. Tables of required distances of separation, based on these calculations, appear in the Draft Building Standards (Scotland) Regulations, 1961.

EXPLOSION HAZARDS

We have been considering flaming combustion over materials in bulk; special problems arise, however, when combustible materials are produced as dusts as in the industrial processes of cutting, grinding, crushing, etc. Due to the increase in surface area of these materials when they are dispersed, flames are propagated at speeds of tens of metres per second. It is clearly important that dangerous dusts should be recognized so that appropriate safety measures can be taken. As these will

increase the cost of the process the tests for hazardous dusts should be realistic. At present, many dusts that seem to have had a good industrial record are classed as dangerous.

Experiments are therefore being carried out on the propagation of flames through mixtures of combustible dusts and inert powders, dispersed at various concentrations, to find the flammable limits (Fig. 6).

Explosion hazards also exist when flammable mixtures of air and vapours are being conveyed along ducts from drying processes. The propagation of flame in such gases may be stopped by using a flame arrester. This consists of a heat exchanger for cooling flames so that combustion can no longer take place. Rapidly moving flames are more difficult to stop than flames moving slowly and experiments have now shown how arresters may be designed to stop flames in gases (8) (Fig. 7).

Occasionally, it is not possible to fit a flame arrester and then precautions have to be taken to ensure that an explosion may be vented before the pressure rises to such a level that the duct is disrupted. This may be achieved by fitting weak sections along the duct (9), which either melt or are blown off as the flame is propagated (Fig. 8).

EXTINCTION

SPRINKLERS AND FIRE DETECTORS

Since many industrial fires occur outside working hours, sprinklers form a valuable means of combating them; not only do they detect fires and give the alarm but they also start to extinguish them. Ideally, a sprinkler should extinguish the fire that has caused it to open and so both the fires necessary to open sprinklers and the extinction of such fires must be studied separately.

A programme of work is now nearing completion in which the opening of sprinklers, both directly above and to one side of various sizes of fire in compartments of various heights, is being studied (Fig. 9). It has been found that the area of fire necessary to open a sprinkler varies with the height of the compartment raised to the power $5/2$. Similar considerations apply to all fire detectors which are thermally operated (10). Information from these experiments in addition to that on the growth of fire in compartments, should help to decide at which stage in a developing fire sprinklers can be expected to open.

The next phase of the work will be to find the rate of application of water necessary to extinguish fires that open sprinklers; it should then be possible to state for the first time in quantitative terms what can be expected of a sprinkler system.

The present tests for thermal fire detectors, based on work carried out by the Joint Fire Research Organization, ensure that detectors operate quickly in building fires without giving false alarms due to vibration and ambient changes in temperature. A corrosion test measures their ability to withstand industrial atmospheres. Due to these tests nearly every commercial detector of the thermal type has been modified to improve its performance.

JET ENGINE

Flaming combustion from extensive fires ceases when the oxygen content of the atmosphere falls to about 14 per cent. In order to extinguish fires altogether, i.e. to prevent smouldering combustion, the oxygen content has to be reduced to a few per cent. Flaming combustion in buildings may be controlled by the injection of large quantities of inert gas, though due to leaks which are likely to occur, particularly under fire conditions, it is not practicable to extinguish fires completely without auxiliary fire-fighting.

A modified jet engine has been constructed which will produce about 45 000 cubic feet of gas per minute having the following composition (11):

Nitrogen	46 per cent
Oxygen	7 per cent
Carbon dioxide	3 per cent
Water vapour	44 per cent

This inert gas will extinguish flaming combustion in a compartment of volume 250 000 cubic feet in about 20 minutes. The injected gases, being hot, rise to the roof and the compartment fills downwards, so that roof fires are extinguished first. Visibility is good and firemen can enter to extinguish the smouldering combustion which will give rise to flaming combustion again if the injection of inert gas is stopped. While it has been found possible to extinguish fires in complicated basements about 100 yards from the point of injection, the visibility was not good and further fire tests are necessary in this type of risk to investigate the clearing of the mist so that firemen may enter under relatively clear conditions.

The jet engine can also be used to produce large volumes of highly expanded foam at about 80 000 gallons per minute. This has the advantage of conveying both inert gas and water to the fire (Fig. 10). The foam contains from $1/500$ to $1/1000$ of its volume of water which improves the extinguishing power of the inert gas by a factor of 2. Difficulties have been found in preventing the water from draining from the foam before reaching a fire but a foam compound has now been found which is much more effective than those previously used. The water in the foam makes it heavier than air despite the buoyancy of the inert gas, so that the foam flows first over the floor and the building fills upwards.

TIMES OF ATTENDANCE AT FIRES

During 1956, the local authority brigades in County Boroughs were attending 80 per cent of the fires within 5 minutes of being called. Since then, however, the traffic has increased in density and a new survey, taking into account time of day, is being made for various cities. The increase in traffic has brought about an increase in noise level and there has been some doubt as to whether the present fire bell would be audible to drivers of heavy lorries. Randomised experiments have been made with various warning sounds and as a result it has been found that the type of sound is not so important as its volume. A fire engine with the present bell can be directly behind a lorry and be inaudible to the driver. The most audible equipment available is a group of four horns which can be heard 140 feet away. The performance of the present fire bell can be improved by amplification so that it can be heard at 70 feet.

ECONOMIC CONSIDERATIONS

Finally, it is necessary to look at the economics of fire protection, for any investment in fire protection should be matched by a reduction in fire loss. The direct loss due to fire is published by 'The Times' and this has risen throughout the last twelve years and particularly since 1959. The direct loss can be compared with the national activity in terms of the Gross National Product and it is found that about $\frac{1}{500}$ of the national effort is destroyed by fire (about four times that due to industrial disputes in 1960). While this fraction decreased during the early fifties, it now seems to be rising again⁽¹²⁾, though it is difficult to say why until further information is available.

The nation makes an investment to prevent or diminish this loss, in designing buildings to prevent the rapid spread of fire, in information services, in local authority and industrial fire

services, in hospital treatment for the injured and in research and development. It also makes an investment in insurance administration. Although the primary purpose of insurance is to redistribute the burden of loss when it occurs, insurance costs include a considerable proportion of technical, survey and other servicing expenses to promote improvement in fire protection and to diminish fire risk. From all these investments, excluding direct fire loss, the nation receives real benefit. The total amounts to between £200 million and £300 million per annum made up as follows:-

TABLE 1
ESTIMATED ANNUAL INVESTMENT IN FIRE

Item	Cost (£ million)
Direct loss (1962)	56.0
Structural protection in buildings	30.0 - 150.0
Local authority fire brigades	30.0
Industrial fire-fighting	20.0
Treatment of injury	0.3
Insurance administration (including technical, survey & other servicing expenses)	50.0
Research & development (government & industry)	0.3
Total	186.6 - 306.6

It is an unsatisfactory state of affairs when the most uncertain item is the cost of fire protection in buildings which is much greater than the current direct fire loss of £56 million. To approach the problem of balancing fire protection with building costs, much more is required to be known about the current

expenditure on fire protection and the ends to which it is being directed. Clearly, it would not be worth making a further investment of £56 million per annum unless the Utopian situation could be reached in which all monetary fire loss had been abolished.

Putting the cost of fire at its lowest figure of £200 million and the national investment in research and development by both government and industry at about £300 000 per annum, the investment in research and development amounts to about 0.15 per cent of the annual turnover in fire expenditure. This is a very modest figure and yet our own nation is among the more enlightened where fire research is concerned.

CONCLUSION

I have tried to give you a picture of the current problems we are facing in research and I hope that you will have seen in it lines of development which should have an important bearing on our understanding of the kinds of fire which occur in buildings, how they develop and how they may be extinguished. New materials and new forms of construction are continuously being evolved but it is only by understanding the problems in this basic way that progress will be made.

The ever rising number of outbreaks and the rising cost of fires seem to be a consequence of living in an affluent society which has new responsibilities and new distractions. Unless new ways of enlisting public co-operation are found, it is difficult to see any way of halting the increasing inroads that fire is making into our economy.

REFERENCES

1. LAWSON, D. I. and SIMMS, D. L. The ignition of wood by radiation. Brit.J.appl.Phys., 1952, 3 (9) 288-92; (12) 394-6.
2. THOMAS, P. H. and BOWES, P. C. Some aspects of the self-heating and ignition of solid cellulosic materials. Brit.J.appl.Phys., 1961, 12 (5) 222-9.
3. THOMAS, P. H. The size of flames from natural fires. pp. 844-59. Ninth Symposium (International) on Combustion. U.S. Combustion Institute. New York, 1963. Academic Press.
4. FUJITA, K. Research report concerning characteristics of fire inside a non-combustible room and prevention of fire damage. Japanese Ministry of Construction Building Research Institute Report No. 2(h). Tokyo.
5. Fire Research 1959. Department of Scientific and Industrial Research and Fire Offices' Committee Joint Fire Research Organization. London, 1960. H.M. Stationery Office. p.11.
6. THOMAS, P. H. et al. Investigations into the flow of hot gases in roof venting. Department of Scientific and Industrial Research and Fire Offices' Committee Joint Fire Research Organization Fire Research Technical Paper No. 7. London, 1963, H.M. Stationery Office.
7. LAWSON, D. I. and HIRD, D. A photometric method of determining configuration factors. Brit.J.appl.Phys., 1954, 5 (2) 72-4.
8. PALMER, K. N. The quenching of flame by perforated sheeting and block flame arresters. pp. 51-7. Symposium on Chemical Process Hazards with Special Reference to Plant Design. Institution of Chemical Engineers. 1961.
9. RASBASH, D. J. and ROGOWSKI, Z. W. Relief of explosions in duct systems. pp. 58-68. Symposium on Chemical Process Hazards with Special Reference to Plant Design. Institution of Chemical Engineers. 1961.

10. PICKARD, R. W., BIGMORE, R. H. and HIRD, D. Gas temperatures beneath ceilings due to steadily burning fires in buildings.
(To be published).
11. RASBASH, D. J. Inert gas generator for control of fires in large buildings. Engineer Lond., 1963, 215 (5601) 978-84.
12. LAWSON, D. I. Fire losses and fire research. Quart.Instn Fire Engrs, 1963, 23 (50) 107-23.

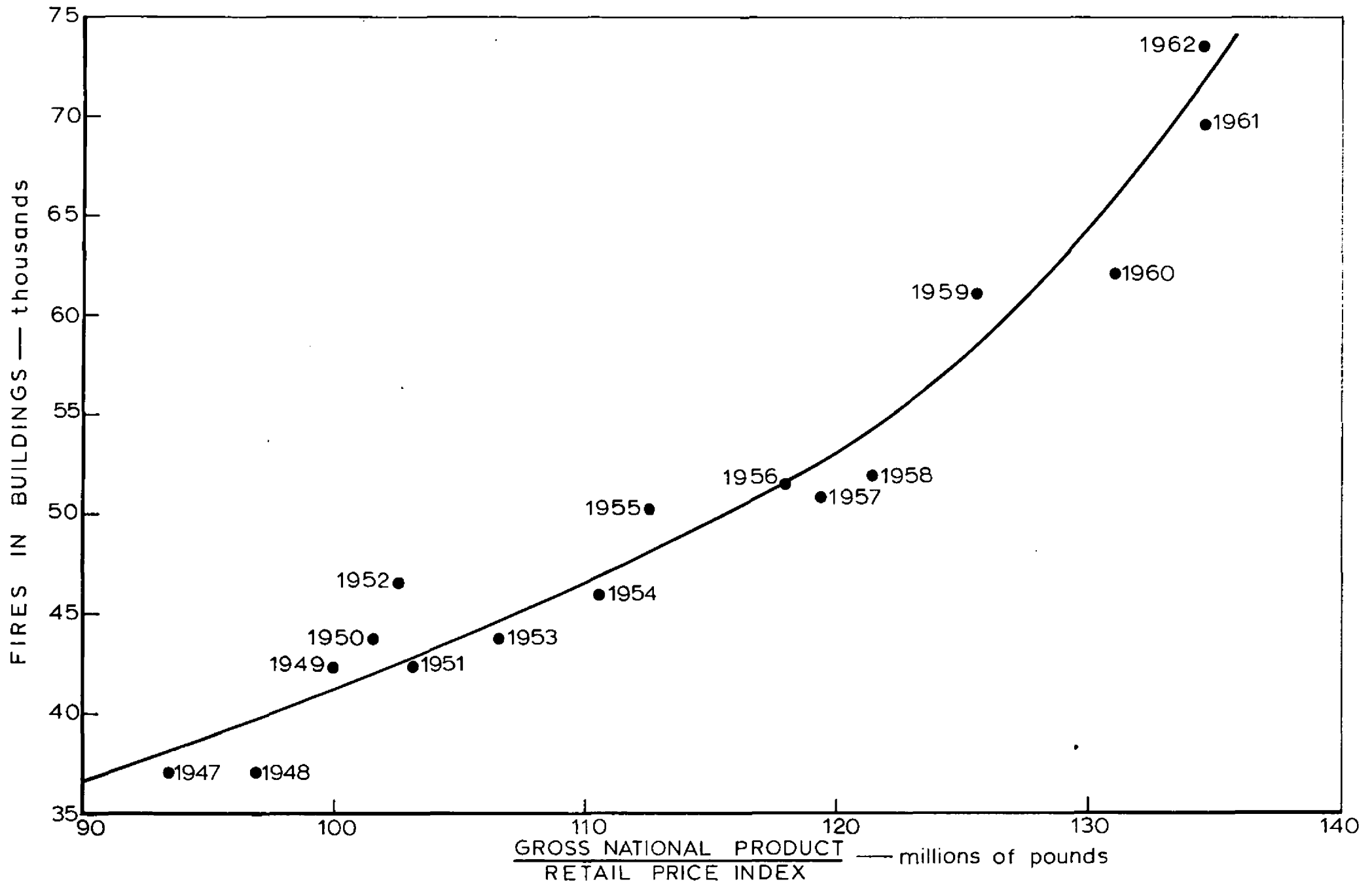

FIG. 1. FIRES IN BUILDINGS AND THE ANNUAL PRODUCTION OF GOODS

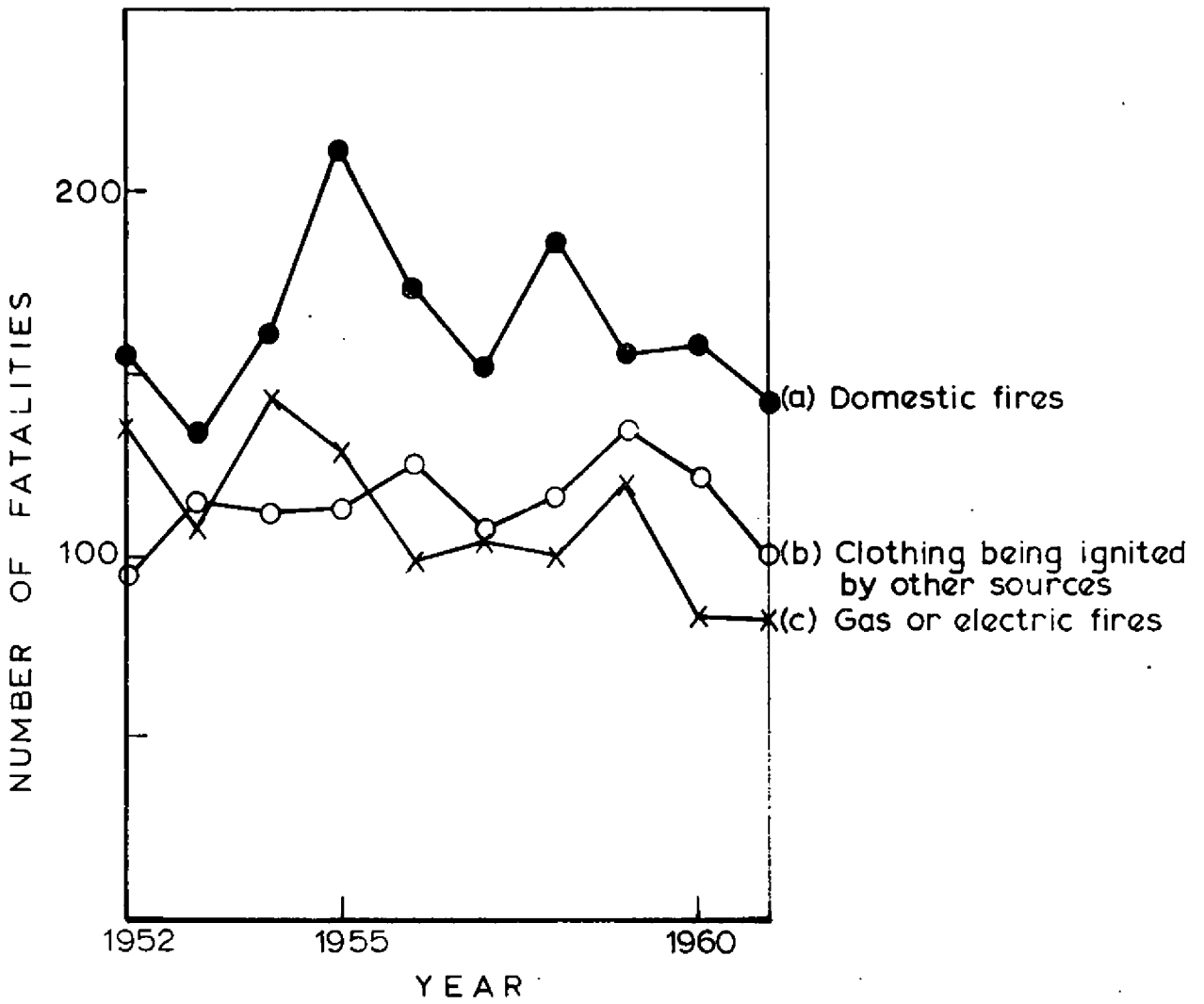
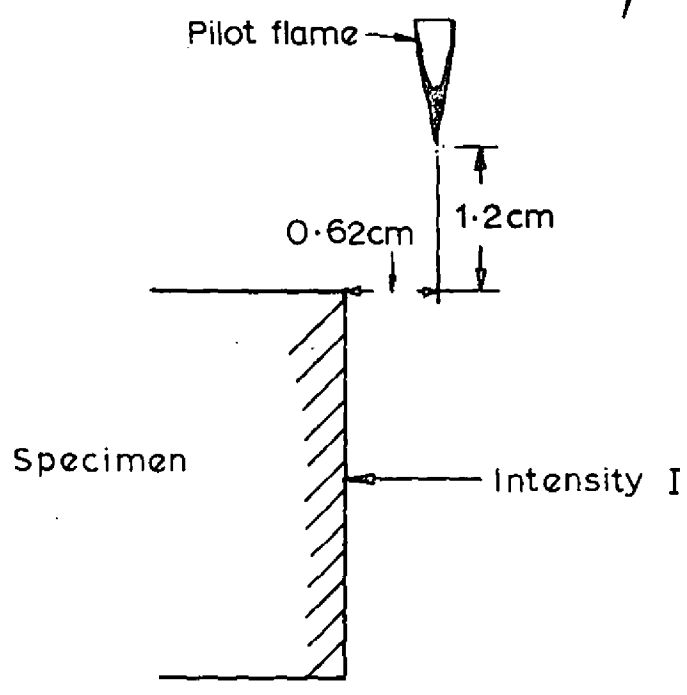
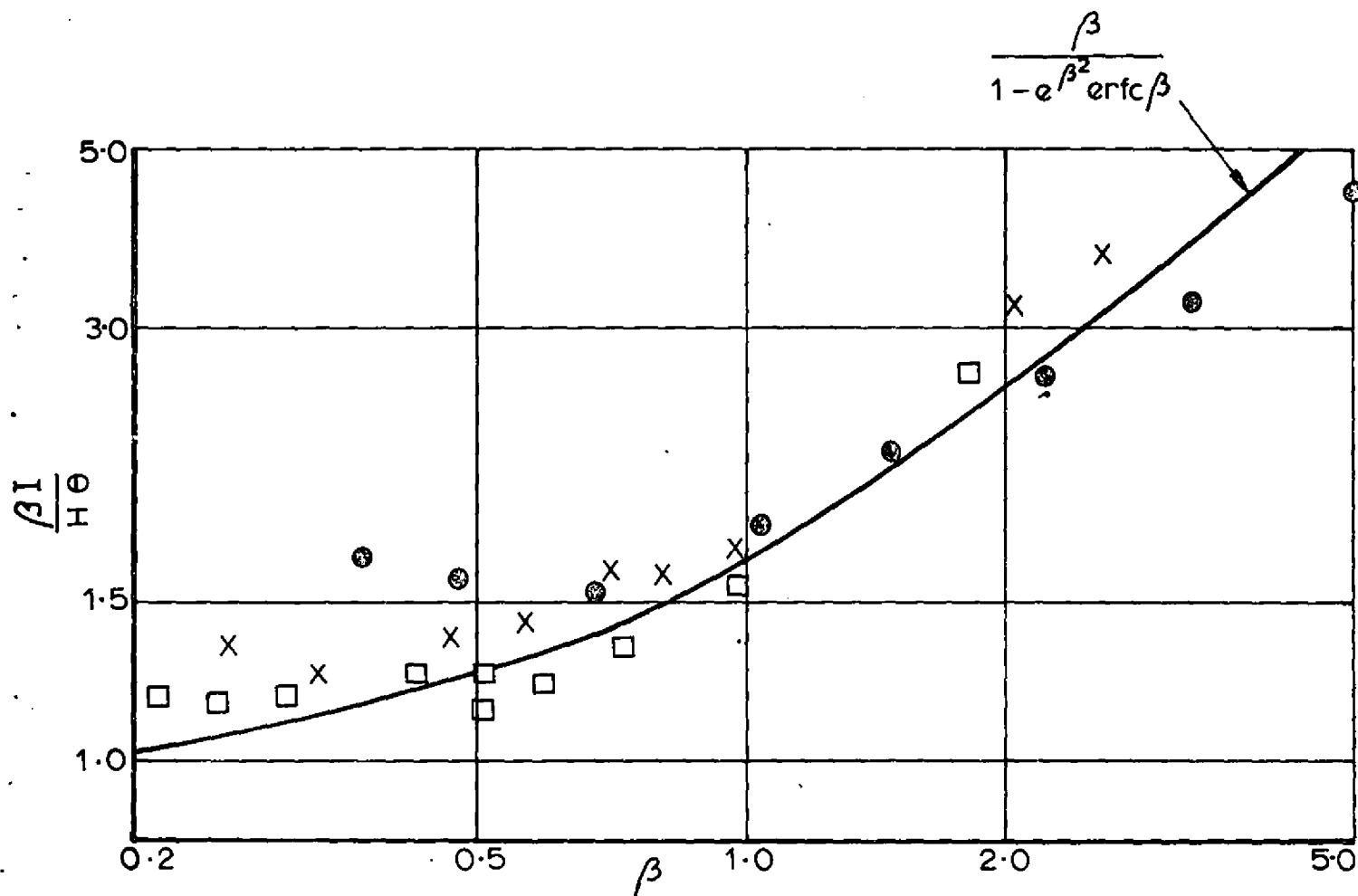

FIG. 2. FATAL ACCIDENTS DUE TO CLOTHING BEING IGNITED BY, OR TO CASUALTY FALLING INTO, FIRE



- X Columbian pine
- Oak
- Fibre insulating board

$$\beta = H \left[\frac{t}{K \rho c} \right]^{1/2}$$

- I - Intensity of radiation
- H - Newtonian cooling coefficient
- K - Thermal conductivity
- ρ - Density
- c - Specific heat
- t - Time of ignition
- θ - Assumed temperature of surface for ignition

FIG. 3. IGNITION OF WOOD

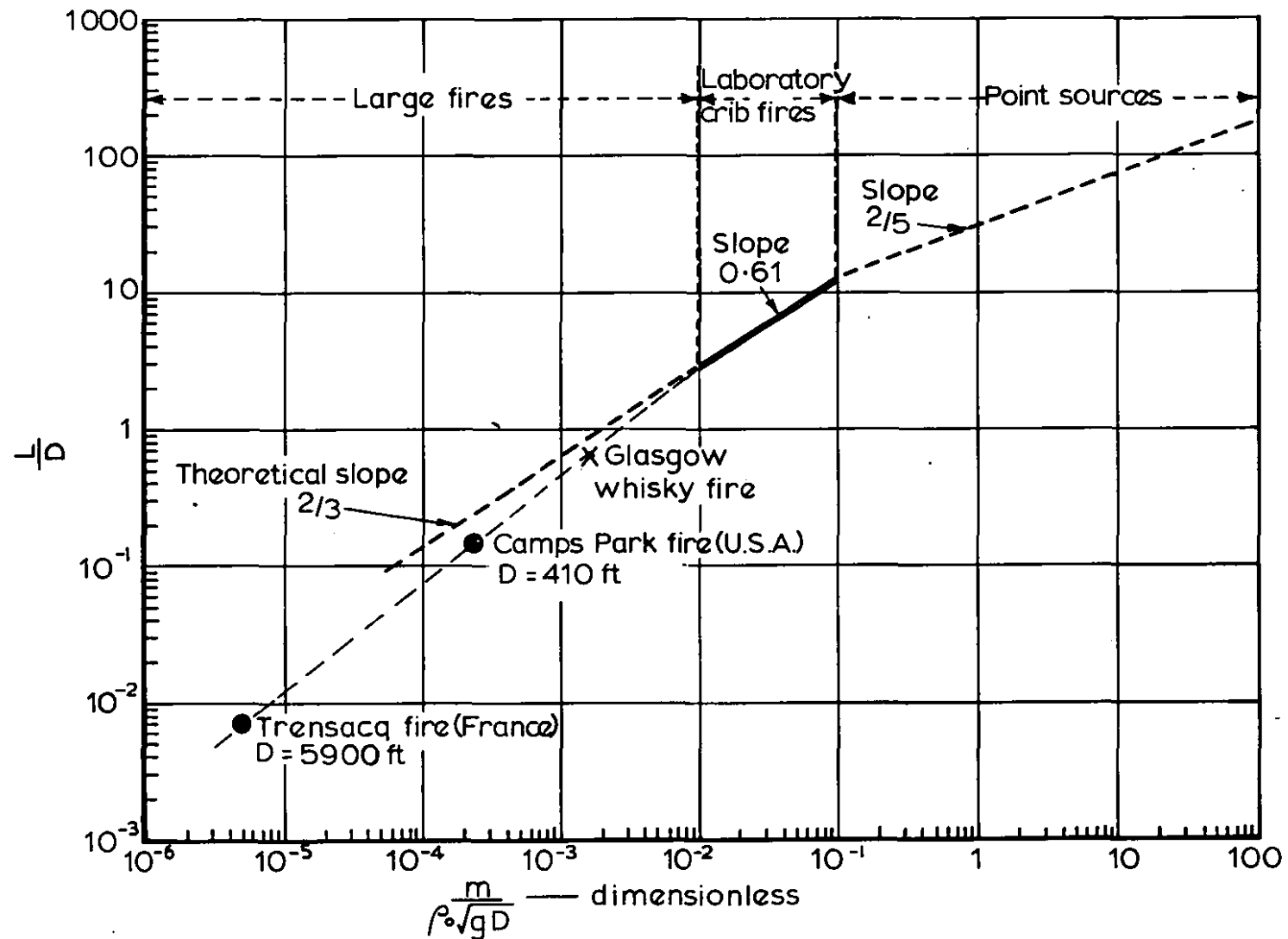

L - Length of flame
 D - Width of fire zone
 m - Rate of burning per unit area
 ρ_0 - Density of air

$n = 2/3$ for large fires
 0.61 for laboratory fires
 $2/5$ for flames from point sources

FIG. 4. SIZE OF FLAME DETERMINED BY THE RELATION $\frac{L}{D} \propto \left[\frac{m}{\rho_0 \sqrt{gD}} \right]^n$

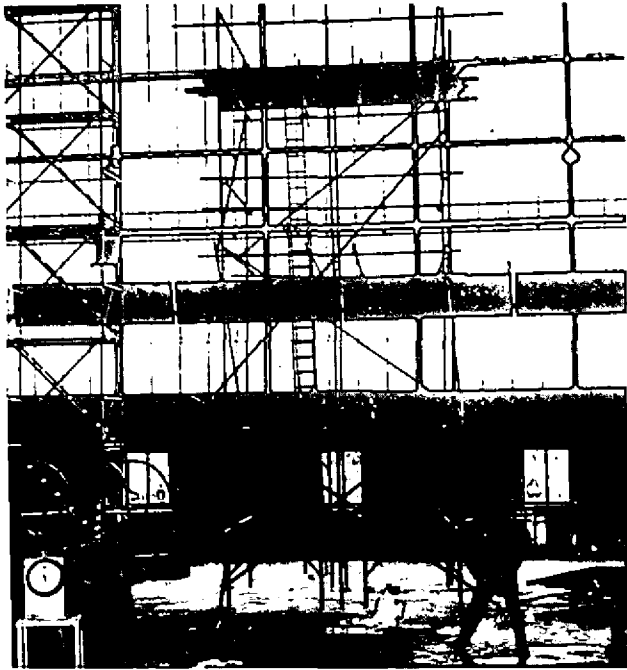

0 min

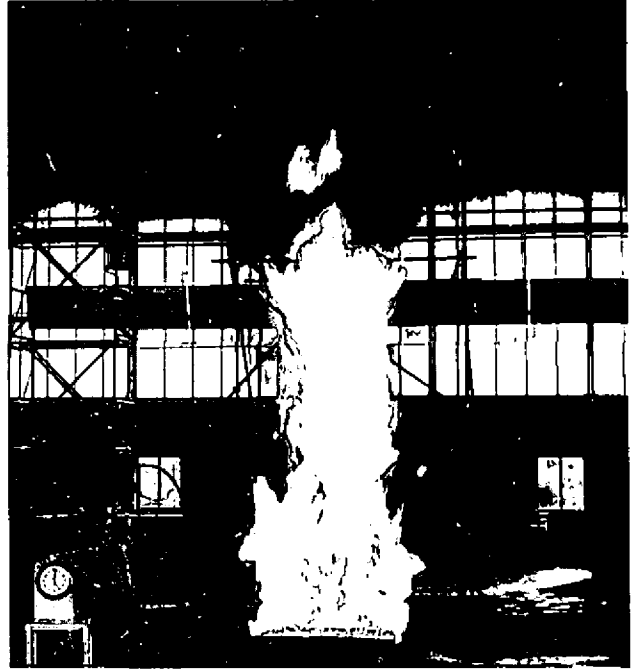

2 min



3 min



4 min



5 min

FIG.5. BLACKING OUT OF 250 000-CUBIC FOOT COMPARTMENT BY PETROL FIRE 20 SQUARE FEET IN AREA

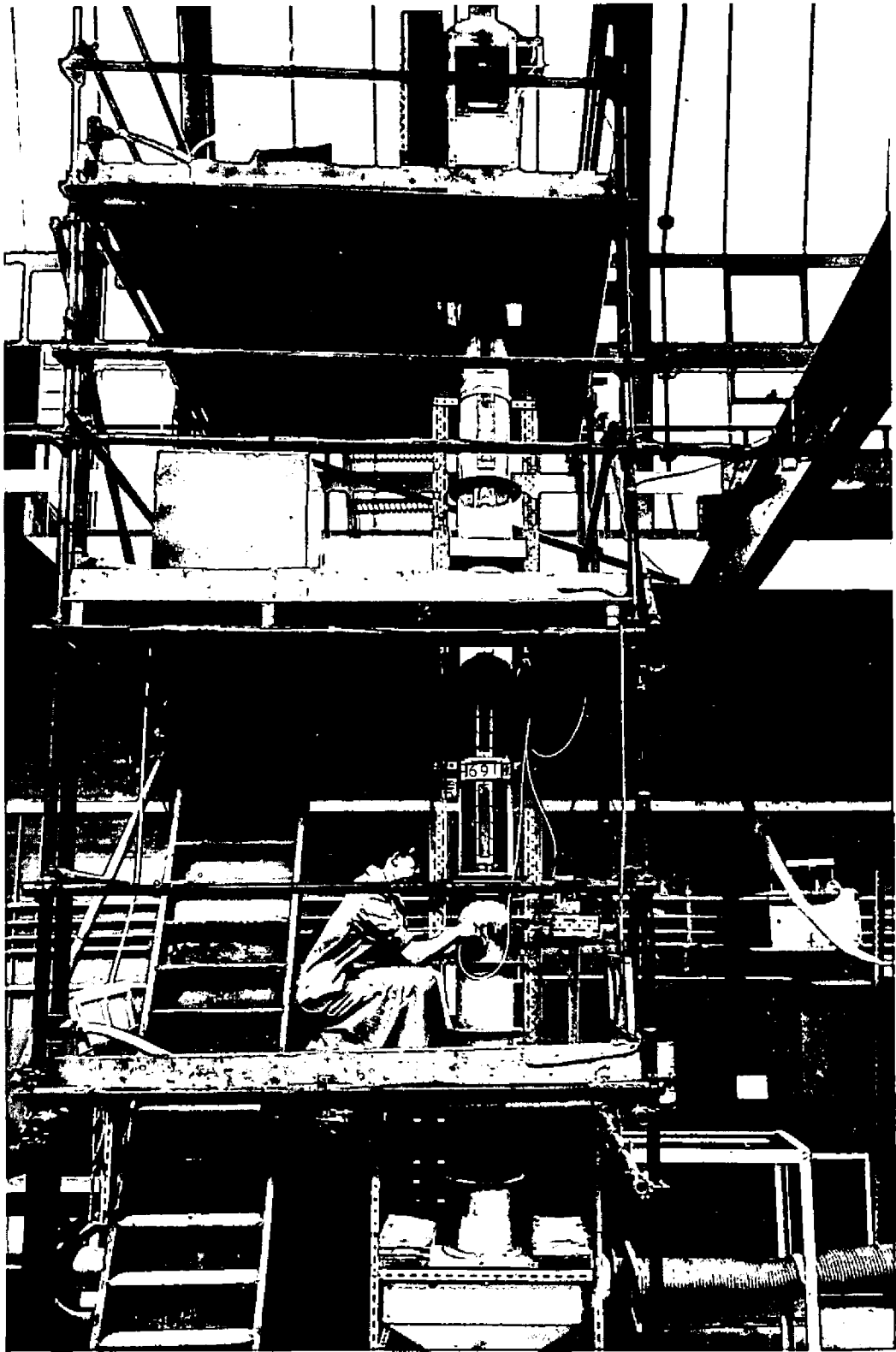
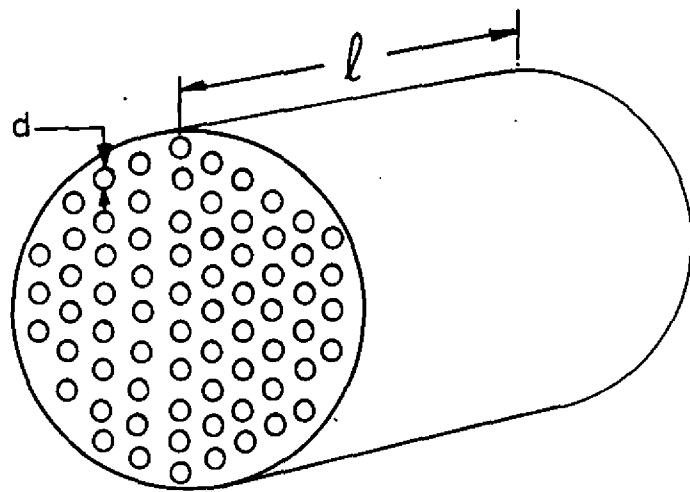
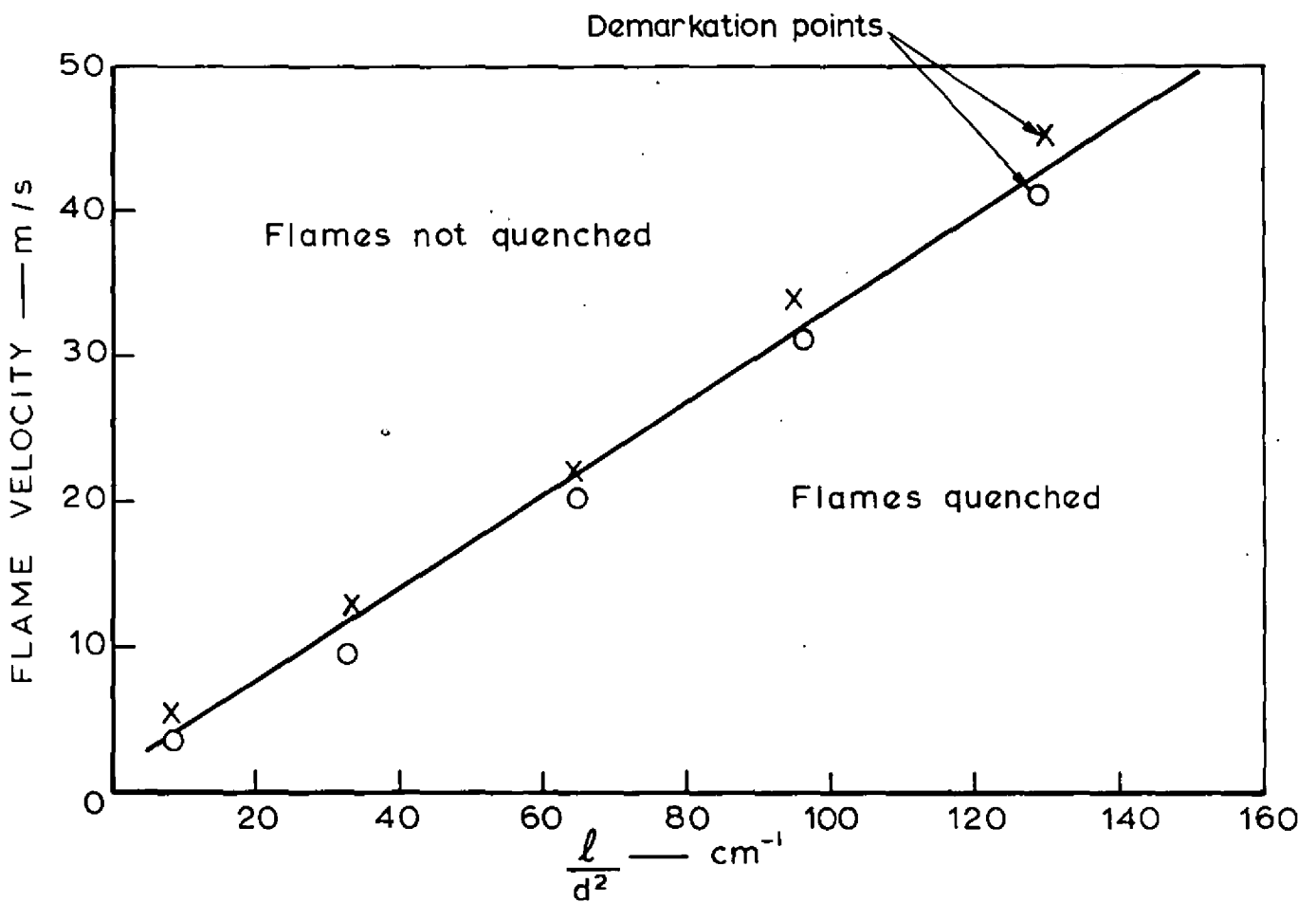

FIG. 6. DUST EXPLOSIONS: LARGE-SCALE VERTICAL EXPLOSION TUBE APPARATUS



PERFORATED BLOCK ARRESTER



($d <$ quenching diameter for flammable mixture)

FIG. 7. FLAME ARRESTER EFFICIENCY

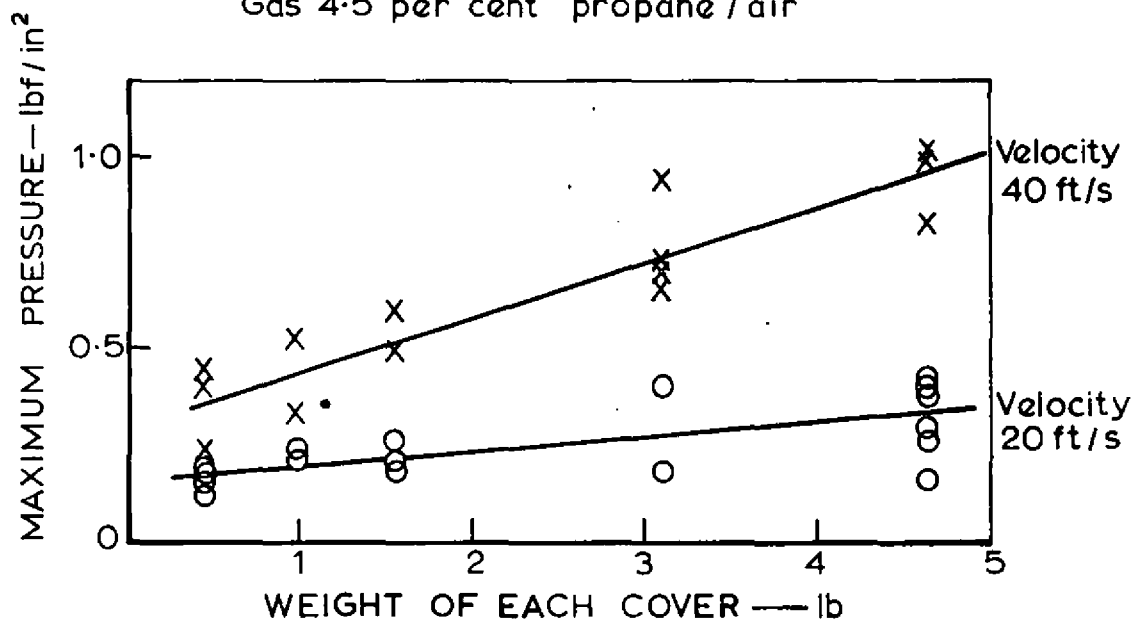
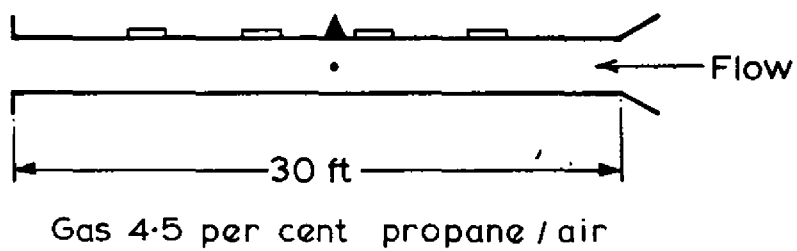
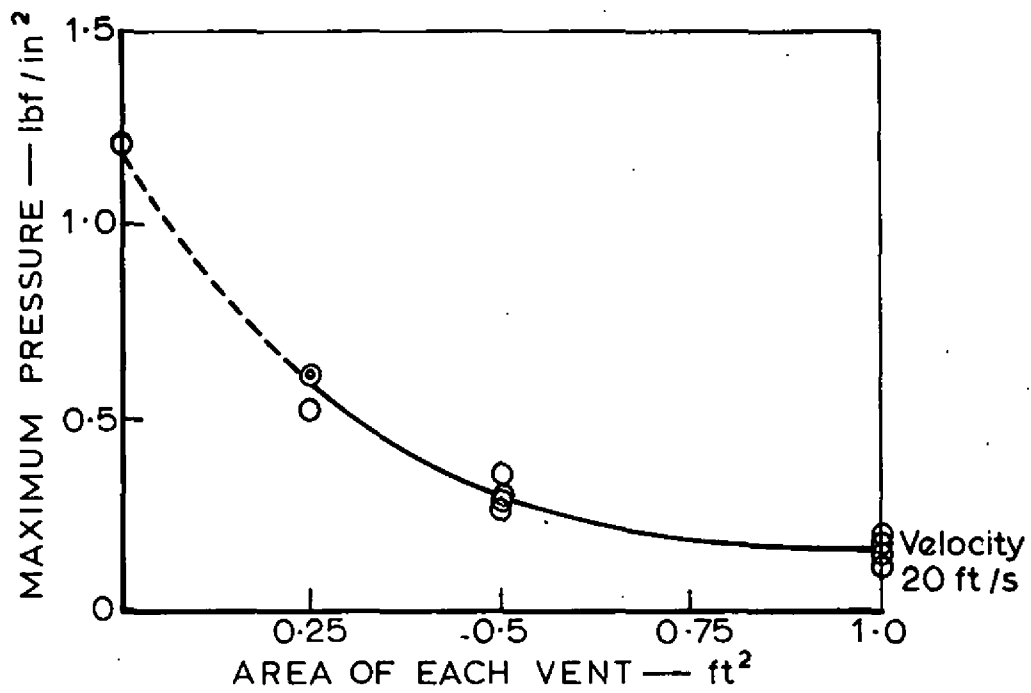
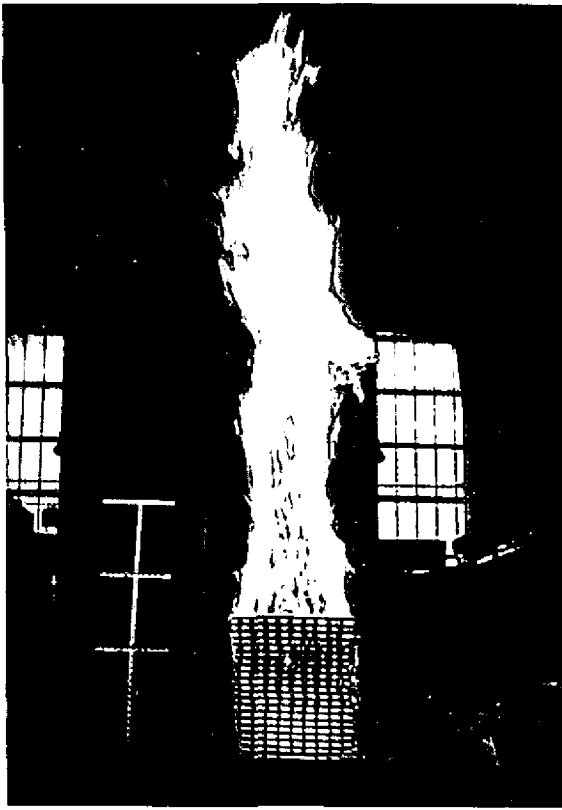
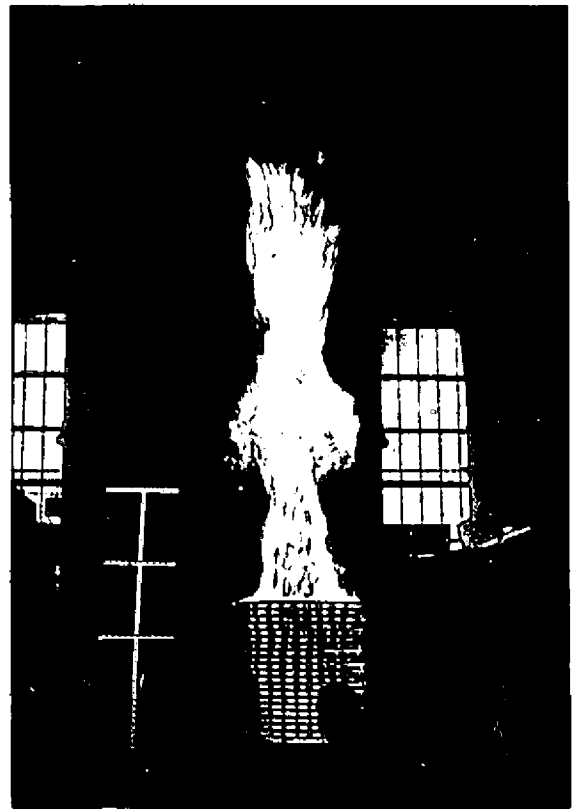

FIG. 8. VENTING OF DUCTS CARRYING FLAMMABLE GASES



(a)



(b)

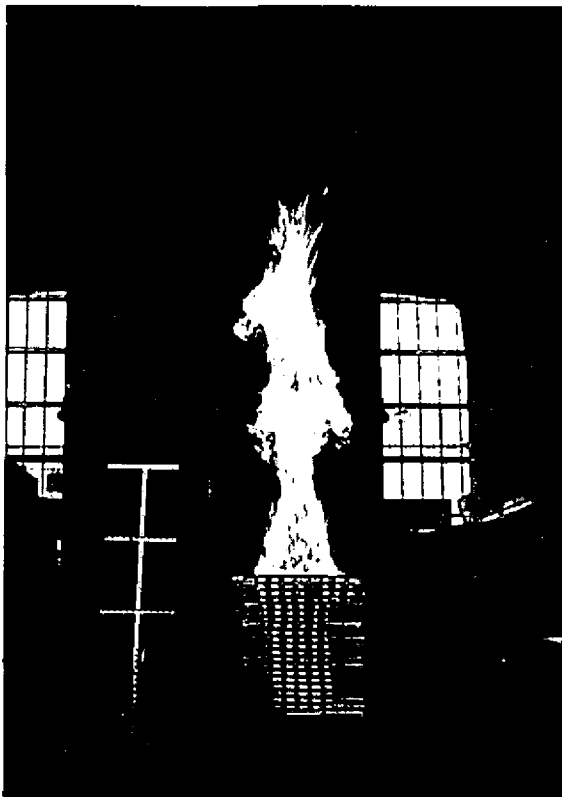

(c)

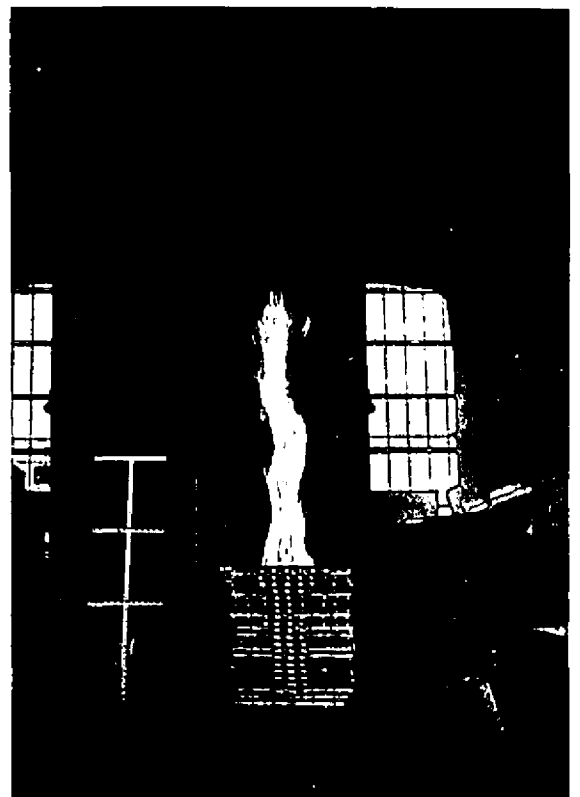

(d)

FIG. 9. SIZES OF FIRE REQUIRED TO OPERATE SPRINKLERS
IN COMPARTMENTS HAVING HEIGHTS
(a) 36 FT (b) 28 FT (c) 16 FT (d) 12 FT

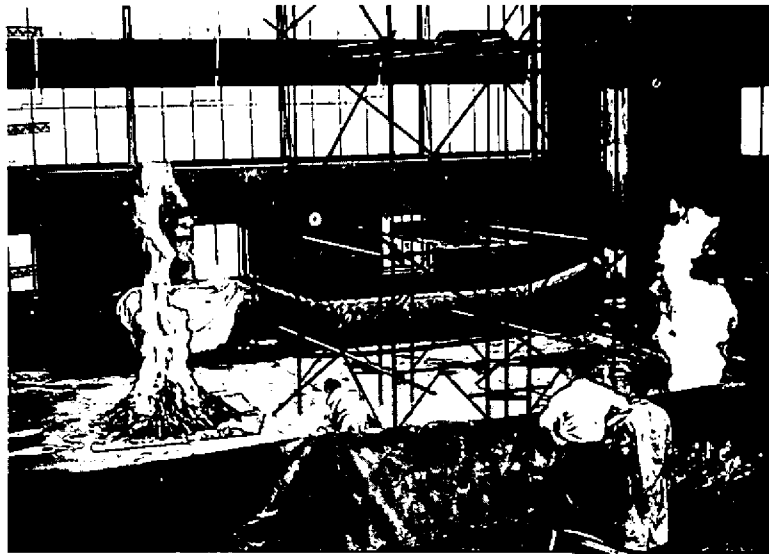

0 min

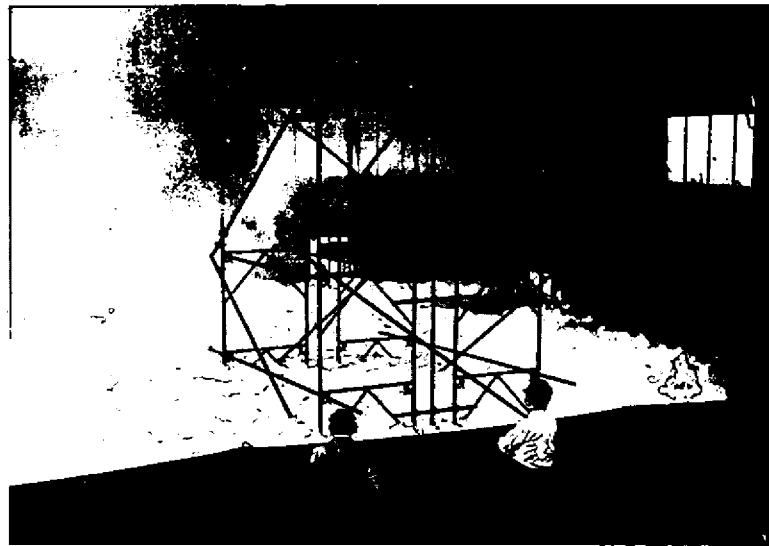

1 min



5 min

FIG. 10. FIRE EXTINCTION BY THE MASSIVE APPLICATION OF HIGHLY EXPANDED FOAM