

LIBRARY REFERENCE ONLY

LIBRARY FIRE RESEARCH STATION BOREHAM WOOD HERTS
No A99FR. NS47

DEPARTMENT OF SCIENTIFIC AND INDUSTRIAL RESEARCH
AND
FIRE OFFICES' COMMITTEE
JOINT FIRE RESEARCH ORGANIZATION

FIRE RESEARCH NOTE

NO. 547

THE PROTECTION OF OIL STORAGE TANKS BY
WATER FILMS

by

P NASH

This report has not been published and should be considered as confidential advance information. No reference should be made to it in any publication without the written consent of the Director of Fire Research.

April, 1964.

Fire Research Station.
Boreham Wood.
Herts.
(phone ELStree 1341)

THE PROTECTION OF OIL STORAGE TANKS BY WATER FILMS

by

P. Nash

Introduction

Oil storage tanks which are subjected to intense heat radiation from a nearby fire will absorb heat which will raise the temperature of the layers of flammable liquid adjacent to the side of the tank. This liquid will tend to rise to the surface by convection and the temperature and pressure in the vapour space above the liquid surface will rise accordingly.

There will be an increase of vapour loss from the vent, and in an extreme case where the vent area is restrictive, the pressure within the tank may rise to dangerous limits. In such cases, a rupture of the tank may occur with catastrophic results; even if this stage is not reached, there is the danger that the vapour plume from the vent may "flash" from the adjacent fire, or from some other source of ignition.

To prevent this sequence of events occurring, it is necessary to cool the exposed surface of the tank by a water film. In the following experiments, one method of providing this film was tested for its efficiency of coverage of the roof and sides of the tank. The note does not discuss whether the total quantity of water supplied was adequate to keep the tank cool under specified intensities of incident heat radiation; this aspect will be discussed in a later note.

Description of tanks and tank protection

The type of protection fitted to the tanks under discussion was provided by a conical pourer placed centrally on the axis of the tank immediately above the apex of the fixed roof (Plate 1 and Fig. 1). The tanks examined were of 21 feet and 120 feet diameter, having a height to the periphery of 30 feet, and a conical fixed roof, the apex of which was 2 feet and 12 feet respectively above the peripheral height. The roof overhung the side of the tank with a "lip" approximately 4 in and 8 in wide for the two diameters (Plate 2 and Fig. 2). This lip had a significant effect on water distribution.

The pourer at the apex comprised a supply pipe of 2 in and 3 in diam., according to tank diameter, fitted with a 4 in x 4 in diam. right-angle elbow. The water discharged from the elbow impinged on a conical plate located with a $\frac{1}{2}$ in clearance between the edge of the cone and the top of the tank. The effect of this clearance was also critical on water distribution.

The construction of the roofs of the tanks was different for the 21 ft and 120 ft diameters. In the first, the roof plates were cut radially as shown in Fig. 3 and in the larger tank the roof plates were arranged in rows as shown in Fig. 4. Lap-welded joints were made between adjacent plates, and in the 120 ft diam. tank, these joints were lapped so that the plates nearer the centre of the tank were lapped under those further away, either when passing from row to row; or from plate to plate in one row. This arrangement of lap joints also had an important effect on water distribution.

Water was supplied via a piped system to each of the tanks in the tank farm area, from a pump house situated outside the bunded area (Plate 2 and Plate 3). Supplies to each tank could be provided by turning on the appropriate valve, the flow rate being varied by varying pump speed, in the range 175-600 gallons/min. The surface areas of tanks, including the conical roof, were 2500 and 25000 sq. ft. respectively, and assuming a transit time of 10 seconds for the water from efflux to ground, this would give a potential distribution on each tank as shown in

Uniformity of Water Distribution on the 30 ft diam. tank

At all flow rates from 175 to 600 gal/min, the whole of the top surface of the tank was wetted, and nearly all of the side surfaces. The difference between this and the 120 ft diam. tank was clearly due mostly to the radial lay of the tank plates, as the radial welds, although lap jointed, had no disruptive effect on the water film. As a result, a uniform distribution occurred at the periphery, and the side distribution was almost complete. As the flow rates represented ten times the water density on the 120 ft diam. tank, any slight disruptive effects the welds or periphery lip might have were masked.

Conclusions

The method of water film distribution described was very sensitive to the following points

- (a) "Set" of the conical impingement plate.
- (b) Method of laying and welding tank top plates.
- (c) Lip at periphery between tank top and tank sides.
- (d) Water flow rate.

While the method was shown to be effective for a 30 ft diameter tank with radial roof plates, it was not nearly so effective for a 120 ft diameter tank with a transverse roof plate layout.

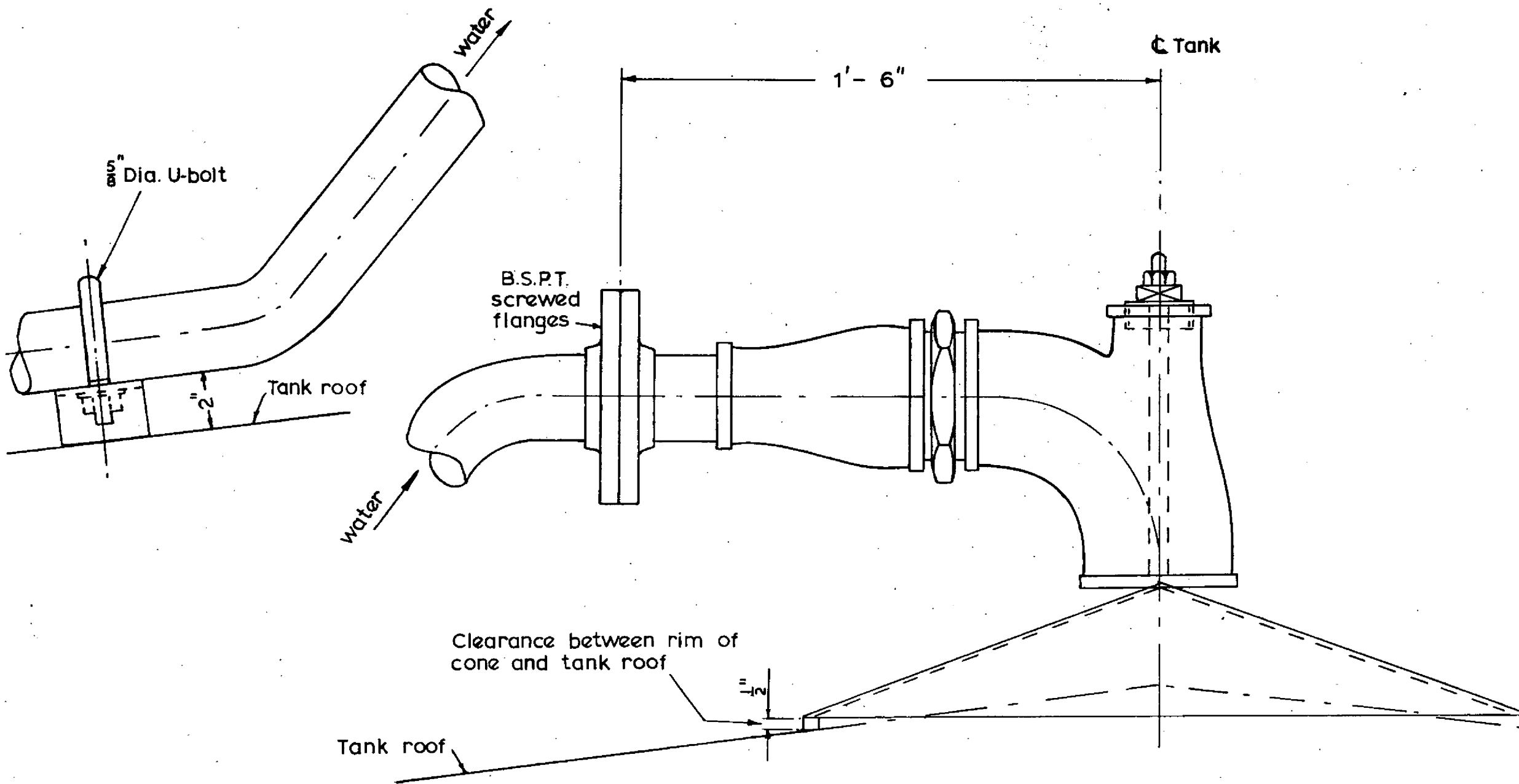
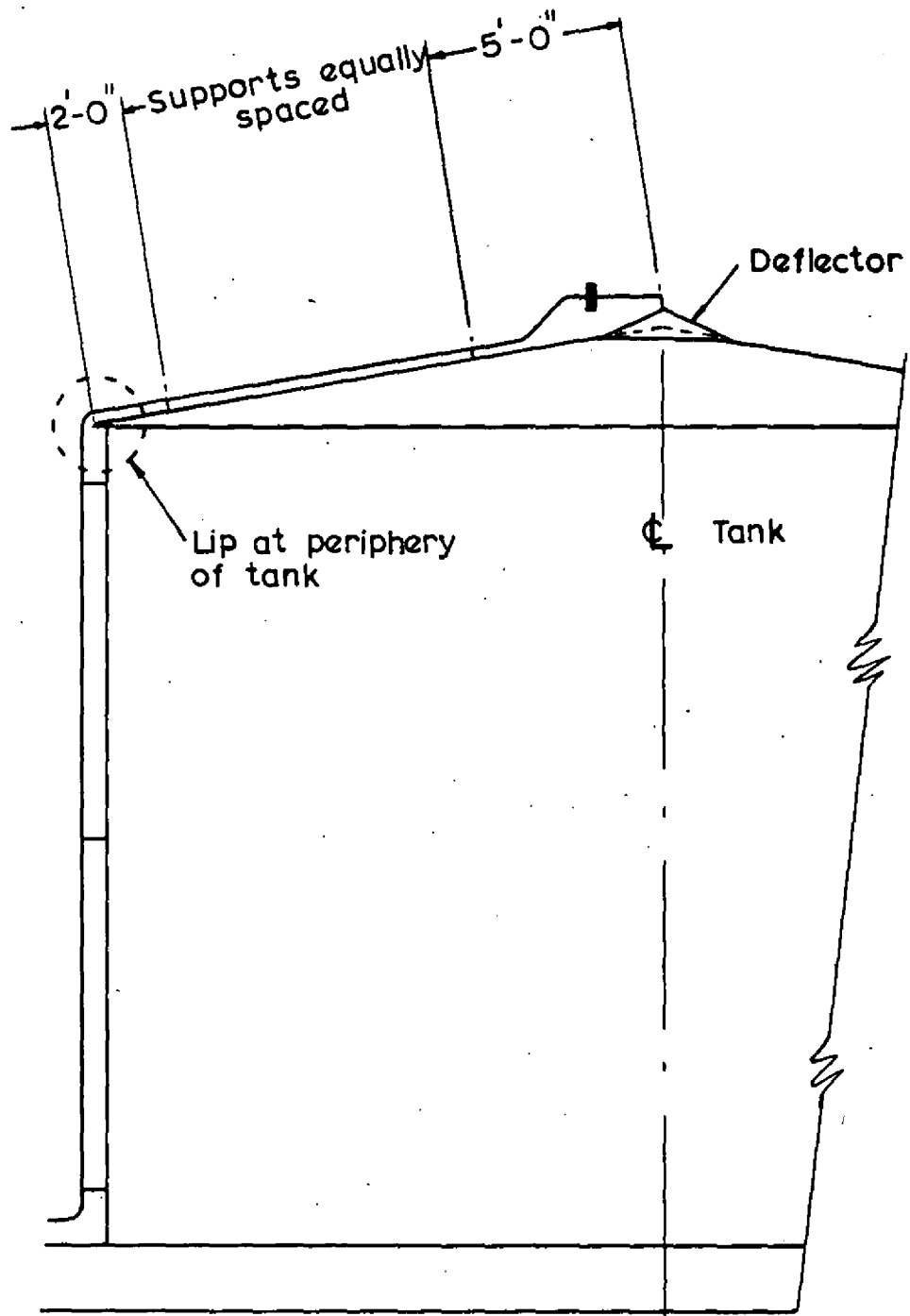

FIG.1. ARRANGEMENT OF WATER POURER



ELEVATION SHOWING PLACING OF SUPPORTS

FIG.2. ARRANGEMENT OF WATER SUPPLY

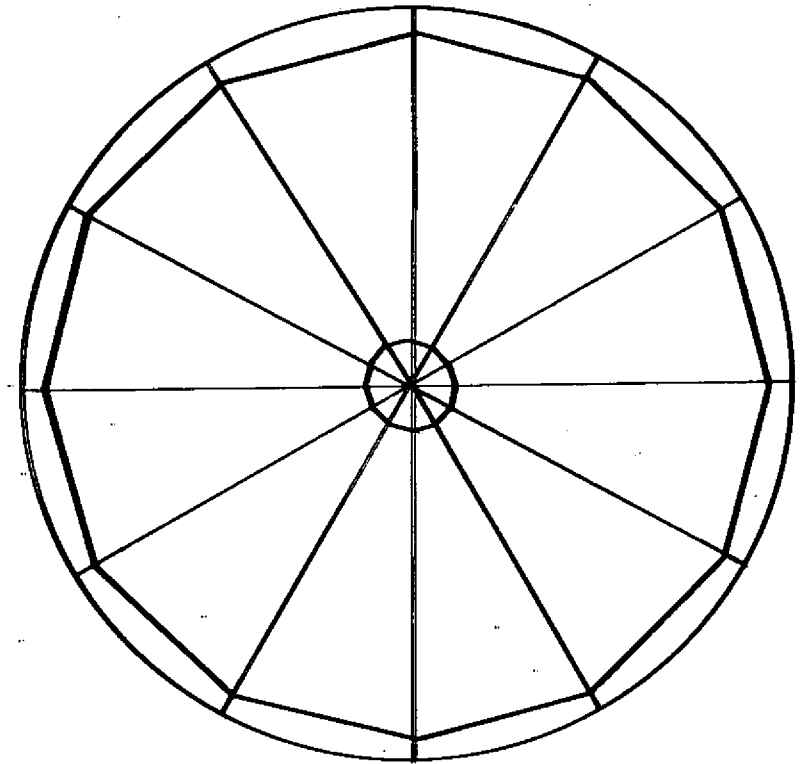
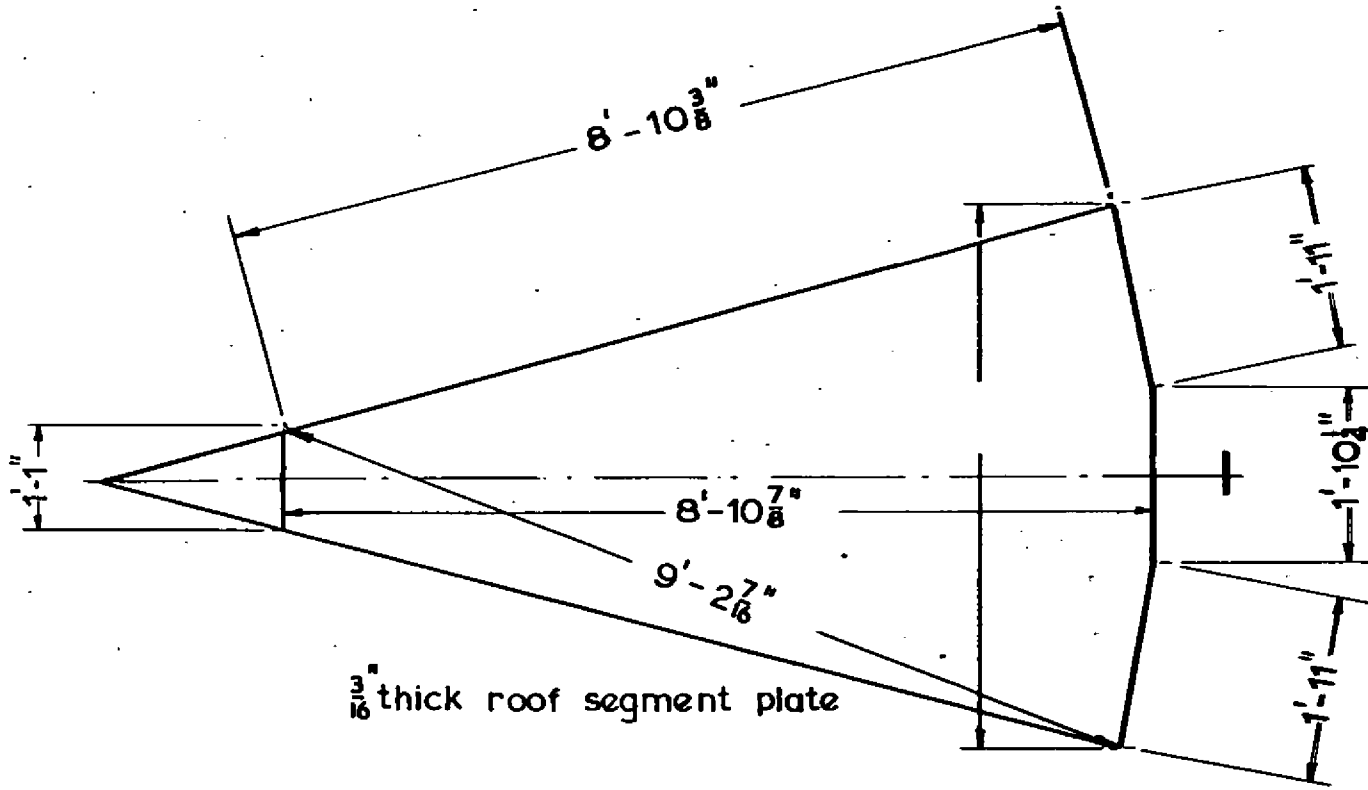

FIG.3. ARRANGEMENT OF ROOF PLATES, SMALL TANK

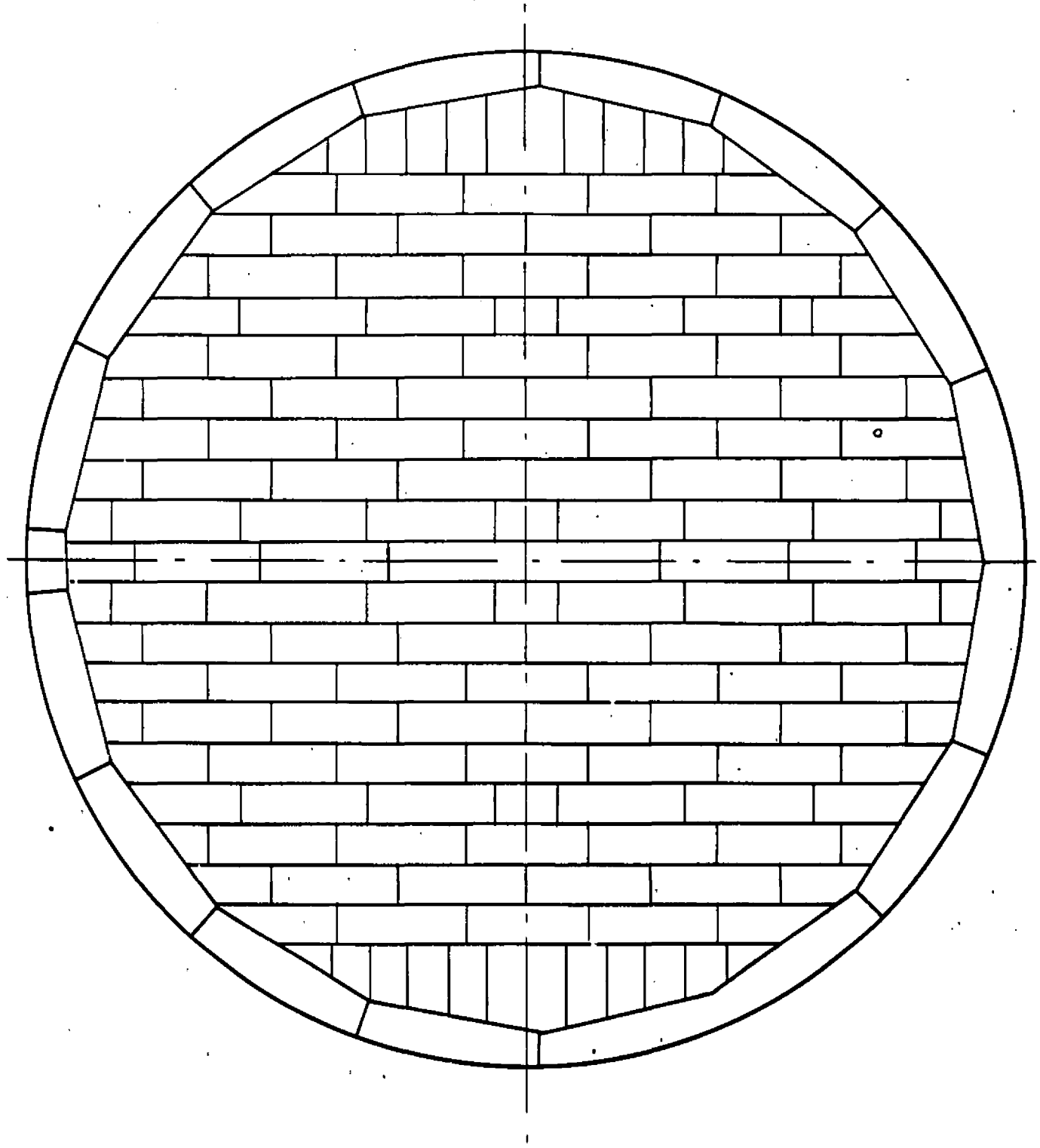

FIG.4. ARRANGEMENT OF ROOF PLATES, LARGE TANK

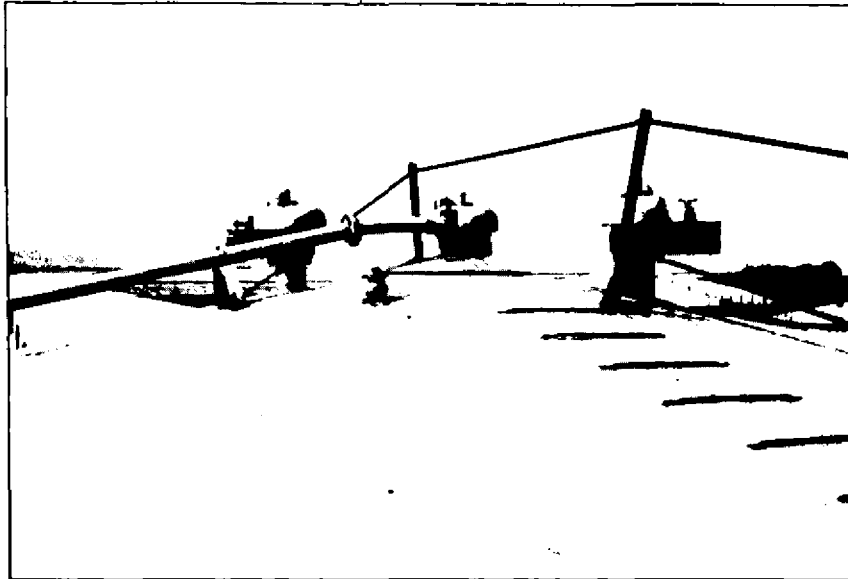

PLATE 1. ARRANGEMENT OF TOP POURER

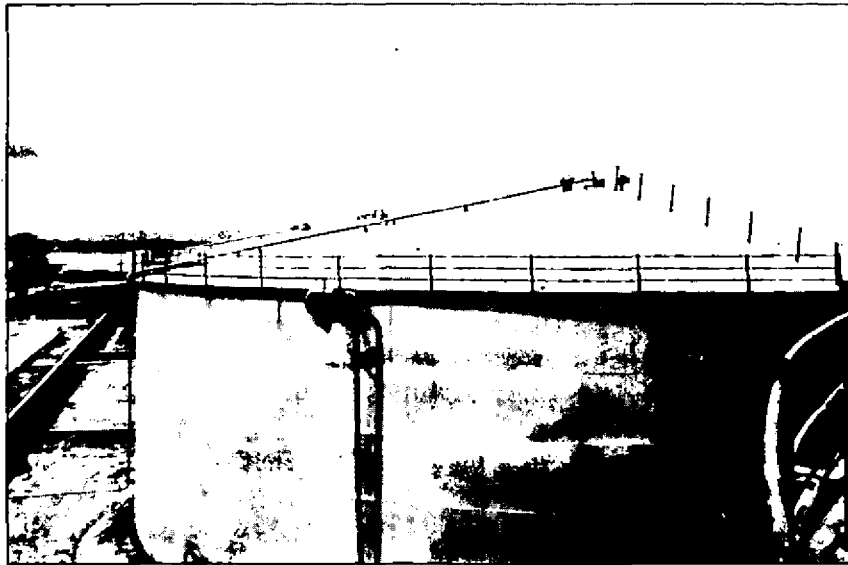

PLATE 2. PIPING ARRANGEMENT

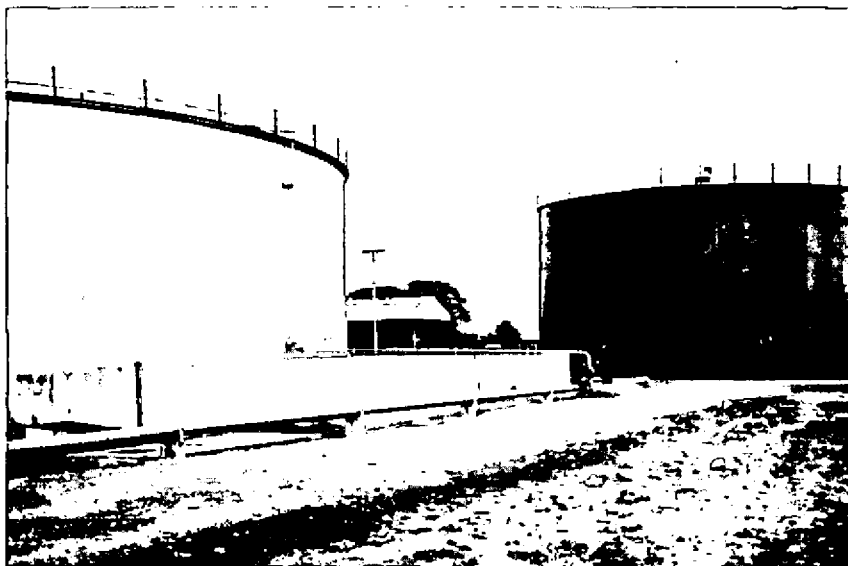

PLATE 3. SUPPLY PIPES AND VALVES