

CONFIDENTIAL

No. A99FR. NS6

F.R. Note No. 56/1953

March, 1953

F. 1002/35/48

This report has not been published and should be considered as confidential advance information. No reference should be made to it in any publication without the written consent of the Director, Fire Research Station, Boreham Wood, Herts. (Telephone: Elstree 1341 and 1797).

DEPARTMENT OF SCIENTIFIC AND INDUSTRIAL RESEARCH AND FIRE OFFICES' COMMITTEE  
JOINT FIRE RESEARCH ORGANIZATION.

A PHOTOMETRIC METHOD OF DETERMINING CONFIGURATION FACTORS

by

D. I. Lawson, M.Sc., M.I.E.E., F.Inst.P and D. Hird, B.Sc.

SUMMARY

A photometric method is described which enables a speedy exploration of configuration factors to be made. The method can also be used to solve the reverse problem of finding the positions with respect to a radiator at which there is a given configuration factor. Whereas the method can be applied more easily to two-dimensional sources of radiation, it can also be applied to many three-dimensional radiators.

INTRODUCTION

It is frequently necessary to calculate the radiation falling onto a receiving surface in the neighbourhood of a radiator maintained at some given temperature. Calculations of this type occur in furnace design, illumination engineering, radiant heating and studies on the growth of fire. These are often very tedious to carry out and the purpose of the present publication is to outline a simple method whereby the calculations may be performed mechanically with an accuracy of a few per cent.

The intensity of radiation at the surface of a "black body" at a temperature  $T^{\circ}A$  is given by

$$I = \sigma T^4 \quad (1)$$

where  $\sigma$  is the Stefan-Boltzmann constant ( $1.37 \times 10^{-12}$  cal/cm<sup>2</sup>/sec/°C<sup>4</sup>). The intensity of radiation falling on a receiver at any distance from the radiator, not only depends on the temperature of the radiating area, but is also a function of the size of the radiator, and the distance and orientation of the receiving element with respect to it. Thus the intensity of radiation at any point with respect to the radiator can be expressed as

$$I_1 = \phi \sigma T^4$$

where  $\phi$  is the configuration factor which may vary between 0 and 1, which takes into account the geometry of the problem. When the receiver is close to the radiator the configuration factor is unity giving  $I = \sigma T^4$ , and when the receiver is at a great distance from the radiator  $\phi$  will have a value tending to zero.

The integral for the configuration factor (Appendix I) is given in most books on heat transfer. The problem does not lend itself well to mathematical treatment in any but the simple cases, examples of which have been worked out mathematically by Barker and Kinoshita (1), McGuire (2) and some other workers. The numerical integration can be replaced by a graphical procedure first mentioned by Herman (3), by an optical projection method (4) or by a mechanical integrator (5). All

these methods depend on the comparison of two areas to give the configuration factor, and the whole procedure must be repeated for each determination of  $\phi$  at different positions with respect to the same radiator. By none of these methods is it possible to do the reverse problem i.e. to find at what position with respect to a radiator there is a given configuration factor. The method described in this paper can be used to solve this problem and gives a speedy method of making a complete exploration of the configuration factor with respect to a radiator. In its present form the apparatus can only solve problems in which the radiating surface is two-dimensional or can be approximated to a two-dimensional equivalent surface.

#### PRINCIPLES OF THE METHOD AND APPARATUS

Since heat and light are propagated according to the same laws, then if a surface radiating heat is replaced by one radiating light under similar conditions, a photocell detector placed close to the surface of the radiator will give a reading representing  $\sigma T^4$  in the heat problem (Equation 1). When placed in the position similar to that of the receiving element it will give a reading reduced by the factor  $\phi$ , the configuration factor. Since the configuration factor is a pure number, the linear dimensions of the radiator can be scaled by any factor providing the distance of the receiver is scaled by the same factor.

An apparatus exploiting this analogy is shown in Fig.1. A model of the radiating area cut out of black photographic paper and covered with a diffusing layer of material is pasted on to the transparent plastic screen which is uniformly illuminated from behind. The inside of section A is painted white to give a high reflectivity. The radiating area is uniformly illuminated and the light radiation from it obeys Lambert's Cosine Law. The inside of section B is painted black to prevent reflected light from falling on the calibrated barrier layer photocell. The cell, with a sensitive area of about  $1 \text{ cm}^2$ , is used in conjunction with a galvanometer to measure the light intensity. If the intensity of the light source can be maintained constant, for instance by incorporating a constant voltage transformer, a calibrated scale can be fitted to the galvanometer to indicate the configuration factor directly. Thus when the photocell is placed close to the radiating area the configuration factor will be unity, and when placed in the position of the receiving element, the configuration factor can be read directly from the scale.

Having set up the model of the radiating area, the configuration factor can be quickly found at any position with respect to the radiator by merely placing the photocell in that position and reading off the configuration factor on the scale. An idea of the laborious computation which is required to solve even the simple case of a receiver on the axis of a rectangle can be seen from the expression for the configuration factor,  $\phi$  in (Fig.2) which shows the accuracy of the method outlined in this paper. The values of configuration factor near to the radiator given by the photometric method are lower than the calculated values. This is not illustrated well by Fig.2 since for small values of distance the curve is ill-conditioned with respect to the  $\phi$  axis. The reason for the low values is that the cell receiving illumination at a large angle of incidence gives a response lower than the correct value, which should be proportional to the cosine of the angle of incidence. The deviation from the theoretical response is commonly known as the "cosine error" of the cell, and a simple method of correcting this error has recently been described by Pleijel and Longmore (6). With this modification to the photocell the values of configuration factor near to the radiator could be found with the same accuracy as those some distance from the radiator.

#### APPLICATION OF THE PHOTOMETRIC METHOD TO PROBLEMS OF TOTAL HEAT TRANSFER BY RADIATION

Problems in furnace design and panel heating as well as many others, often require a knowledge of the total heat transfer between two finite bodies, and not the amount of heat falling on a small element from a finite source. In this case the configuration factor of the whole receiving element with respect to the radiator is required. This is known as the integrated or mean configuration factor,  $\bar{\phi}$ , and can be obtained from the

expression for  $\phi$  in Appendix I by integration over the area  $A_2$ . If we consider it as the mean configuration factor, that is to say the mean of the values of configuration factor for elements distributed all over the area  $A_2$ , then it can be expressed as

$$\bar{\phi} = \frac{1}{A_2 \pi} \iint_{A_1, A_2} \frac{\cos \theta_1 \cos \theta_2}{r^2} dA_1 dA_2$$

A close approximation can be made for the mean configuration factor ( $\bar{\phi}$ ) of a large receiving surface by taking the configuration factor,  $\phi$ , at a few points on it in suitable positions with the photocell and taking the average of these values.

Many problems involve the transfer of heat from several surfaces. It is useful to remember in these cases that configuration factors can be added and subtracted and the configuration factor can thus be found separately for each surface, the total configuration factor being given by the sum of the values.

A solution of particular cases in which the radiator is three-dimensional, can be obtained using the photometric method, since it is the contour of a surface and not the form which determines the value of  $\phi$ . Thus the surface of a radiator may be replaced by an equivalent surface provided the angular cover at the receiver is the same. This can be easily seen by considering the configuration factor of a sphere at a distance  $x$  (Fig.3).

The value of  $\phi$  at a point distant  $x$  from the centre of the sphere centred on  $O$ , would be identical with the value for the disc  $AB$  at a distance  $y$ , or the disc  $CD$  at a distance  $z$ .

#### CONCLUSIONS

The photometric method of determining configuration factors described in this paper is particularly useful if the configuration factor at many positions with respect to a radiator is to be found. It is also possible by this method to find at what position with respect to a radiator there is a given configuration factor. The authors know of no other method of solving this problem for any but the simplest cases.

#### ACKNOWLEDGEMENT

The work described in this paper forms part of the programme of the Joint Fire Research Organization of the Department of Scientific and Industrial Research and Fire Offices' Committee; the paper is published by permission of the Director of Fire Research.

#### REFERENCES

- (1) BARKER, A. H. and KINOSHITA, M. Report of research on the effect of the shape and surroundings of a hot surface on the radiation from it. University of London, University College Department of Heating and Ventilating Engineering Bulletin No.1. London, 1923. Unwin Bros., Ltd.
- (2) McGUIRE, J. H. Heat transfer by radiation. (To be published).
- (3) HERMAN, R. A. Treatise on Geometrical Optics. (Cambridge: Cambridge University Press, 1900).
- (4) ECKERT, E. Z.Ver.Dtsch. Ing., 79, p.1495.(1935).
- (5) HOTTEL, H. C. Mech. Engng, 52, p.699.(1930).
- (6) PLEIJEL, G. and LONGMORE, J. J.Sci.Instrum., 29, p.137. (1952).

APPENDIX I

The intensity of radiation at any point with respect to a radiator can be expressed as

$$I = \phi \sigma T^4 \quad (1)$$

where  $\phi$  is the configuration factor.

The fundamental expression for  $\phi$  can be deduced from Fig. 4.

If  $\theta_1$  and  $\theta_2$  are the angles made by the normals to  $A_1$  and  $A_2$  and  $d\omega_2$  is the solid angle subtended by the receiving element  $dA_2$  at the radiator, then the energy falling on an element of the receiver in unit time is

$$\frac{dA_1 \epsilon \sigma T^4 \cos \theta_1}{\pi} d\omega_2$$

and since

$$d\omega_2 = \frac{dA_2 \cos \theta_2}{x^2}$$

the energy falling on  $dA_2$  in unit time from the element  $dA_1$  of the radiator is

$$\frac{\epsilon \sigma T^4}{\pi} dA_1 \cos \theta_1 \frac{dA_2 \cos \theta_2}{x^2}$$

Considering this as the intensity of radiation at  $dA_2$  from the whole radiator

$$I = \frac{\epsilon \sigma T^4}{\pi} \int_{A_1} \frac{\cos \theta_1 \cos \theta_2}{x^2} dA_1$$

Comparing this with (1) the expression for  $\phi$  becomes

$$\phi = \frac{1}{\pi} \int_{A_1} \frac{\cos \theta_1 \cos \theta_2}{x^2} dA_1$$

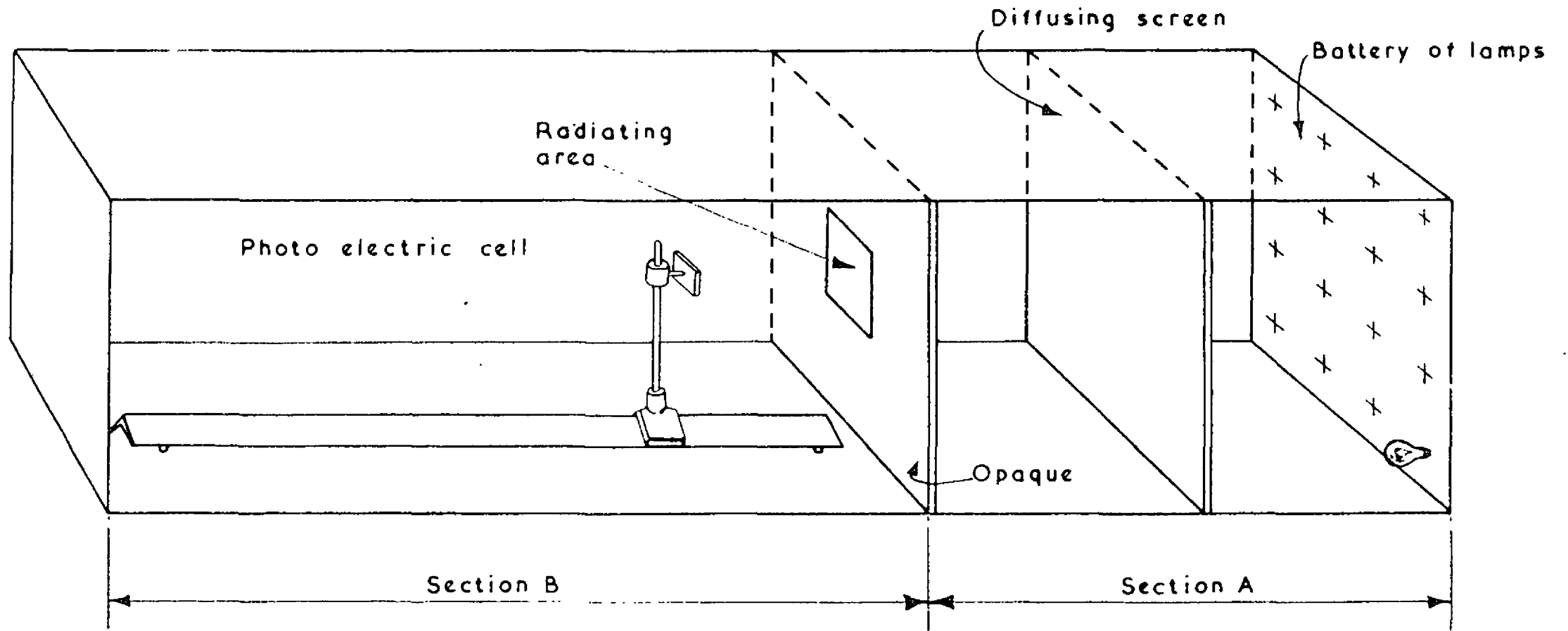

FIG.1. APPARATUS FOR DETERMINATION OF CONFIGURATION FACTOR

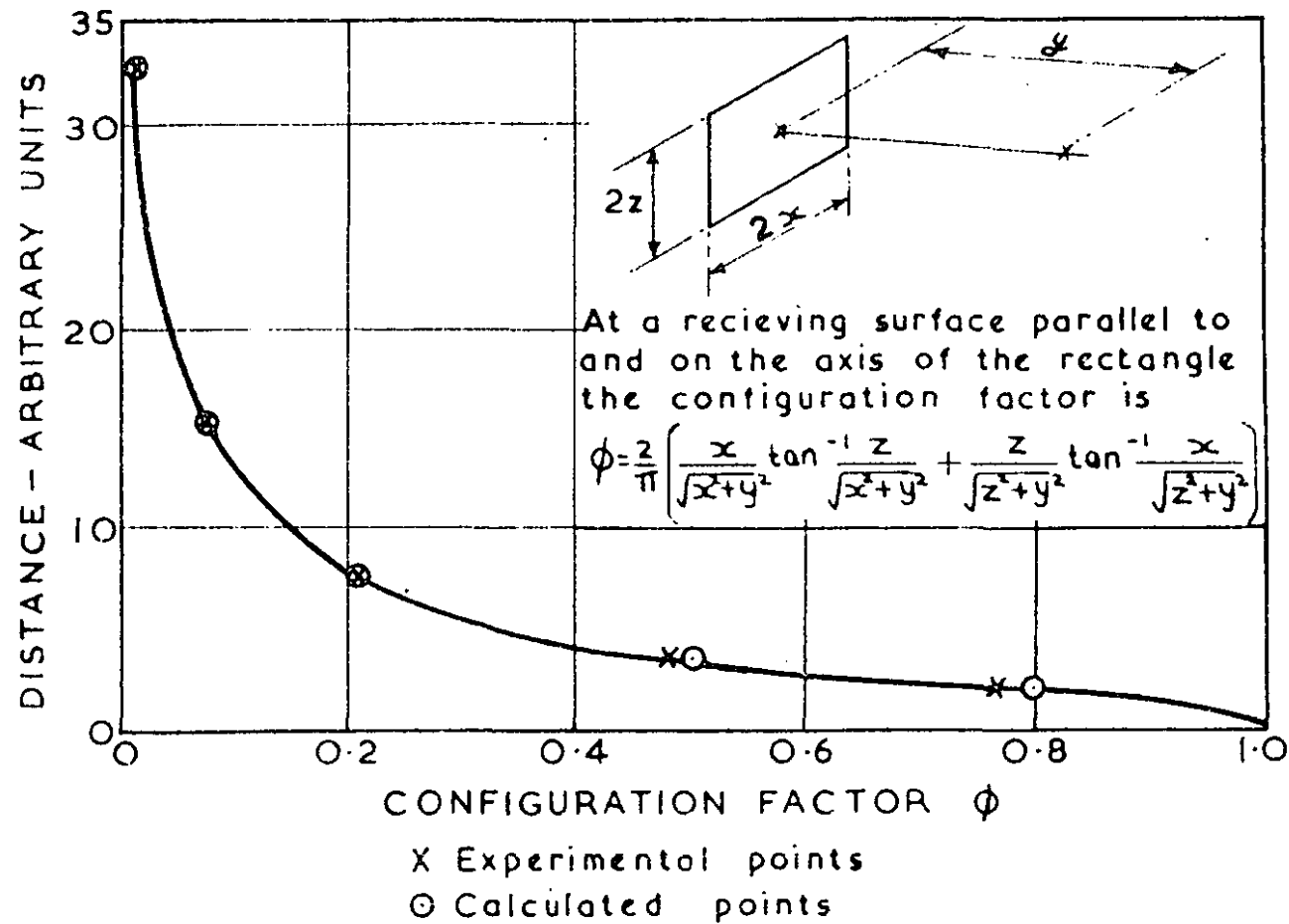

FIG. 2. CONFIGURATION FACTOR AT VARIOUS DISTANCES ALONG AXIS OF RECTANGULAR SOURCE HAVING DIMENSIONS 6X9.14 ARBITRARY UNITS

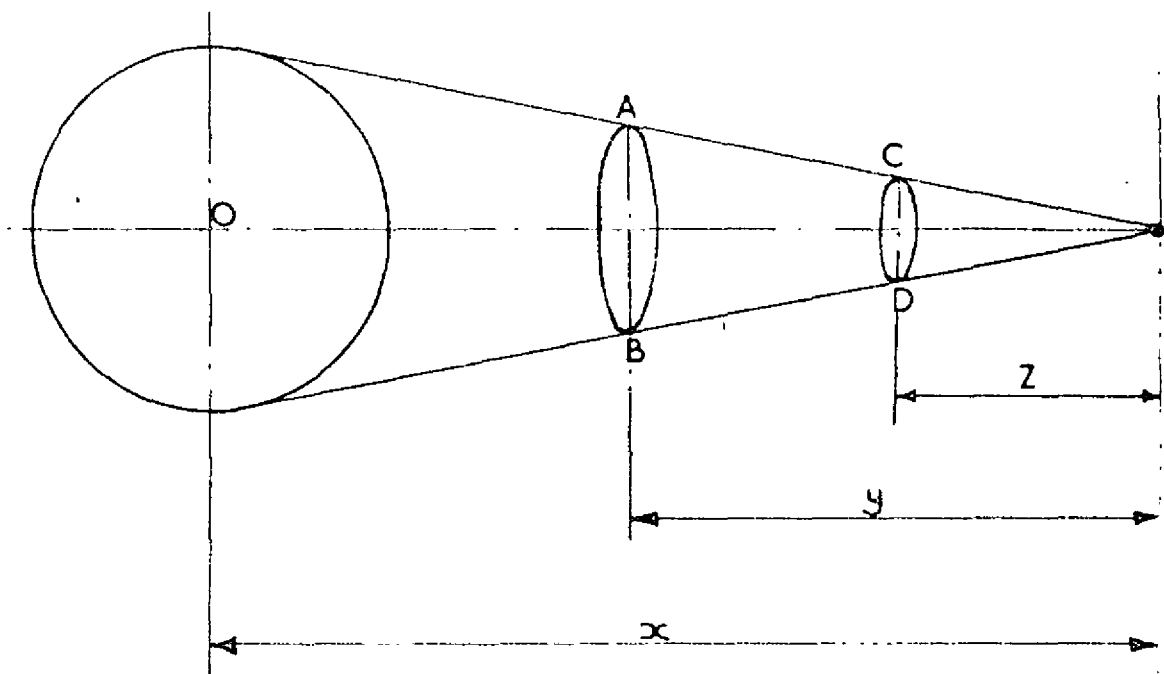

FIG. 3. CONFIGURATION FACTOR OF SPHERE AND EQUIVALENT RADIATING SURFACES

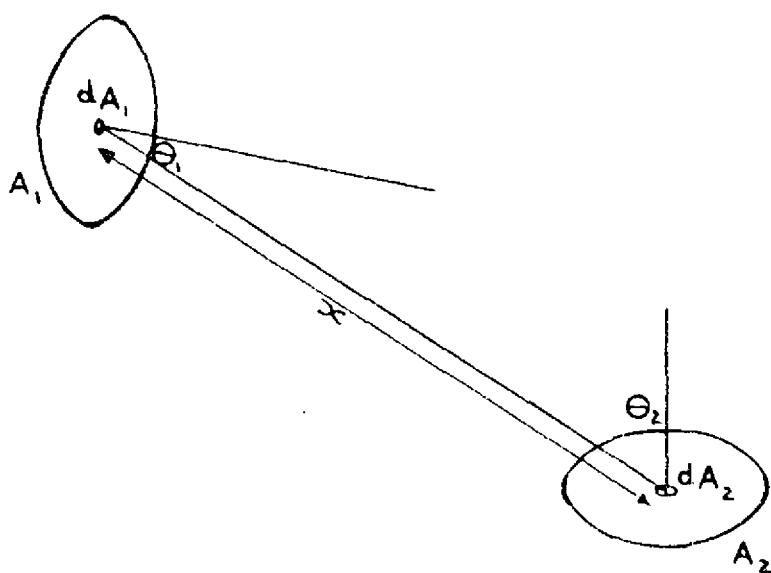

FIG. 4. THE TRANSMISSION OF RADIATION BETWEEN TWO SURFACES  $A_1$  &  $A_2$