

LIBRARY REFERENCE ONLY

M.O.T. AND F.O.C.
FIRE RESEARCH
ORGANIZATION
REFERENCE LIBRARY

No. A99FR. N583

DEPARTMENT OF SCIENTIFIC AND INDUSTRIAL RESEARCH

AND

FIRE OFFICES' COMMITTEE

JOINT FIRE RESEARCH ORGANIZATION

FIRE RESEARCH NOTE

NO. 583

**THE DESIGN AND DEVELOPMENT OF AN EXPERIMENTAL
GAS TURBINE OPERATED FOAM GENERATOR**

by

D. W. FITTES and P. NASH

This report has not been published and should be considered as confidential advance information. No reference should be made to it in any publication without the written consent of the Director of Fire Research.

January 1965.

Fire Research Station.
Boreham Wood.
Herts.
(phone ELStree 1341)

F.R. Note No.583.

DEPARTMENT OF SCIENTIFIC AND INDUSTRIAL RESEARCH AND FIRE OFFICES' COMMITTEE
JOINT FIRE RESEARCH ORGANIZATION

THE DESIGN AND DEVELOPMENT OF AN EXPERIMENTAL
GAS TURBINE OPERATED FOAM GENERATOR

by

D. W. Fittes and P. Nash

Summary

This note describes the design and development of an apparatus which will produce large quantities (up to about 5,000 g.p.m.) of fire fighting foam, having various pre-determined physical characteristics. The apparatus was produced for use in a series of experimental mock aircraft fires, to determine the optimum properties of foam for fire control. The design would be likely to form a possible basis of future aircraft crash tenders, either landborne or airborne.

THE DESIGN AND DEVELOPMENT OF AN EXPERIMENTAL GAS TURBINE OPERATED FOAM GENERATOR

by

D. W. Fittes and P. Nash

INTRODUCTION

At the request of the Aircraft Crash Fire Panel, which consists of representatives from various Government Departments, a programme of large scale mock aircraft crash fires was made at the Ministry of Aviation Fire Training School, Stansted Aerodrome, Essex, during the summer and autumn of 1964. The purpose of the programme was to determine the optimum physical characteristics of foam for use against aircraft fires.

The main difficulty associated with the large scale testing of fire fighting foams is in the control of the physical characteristics of these foams. This note describes the design and development of a self-propelled apparatus based on an idea by Nash and French⁽¹⁾ which will produce large amounts of foam having various pre-determined physical characteristics. Although this apparatus was primarily designed for these experiments, experience in its use suggests that it would form a basis for the design of future aircraft crash fire tenders, the actual working parts of the foam generator being lighter and considerably less bulky than the conventional pump with its driving engine.

VEHICLE

The foam-making apparatus is carried on a 10 ton capacity Leyland 'Hippo' chassis. (Plates 1 and 2).

FOAM GENERATOR

The principle of operation of the foam generator is as follows. Compressed air from the turbo-compressor (A) (Figure 1) passes through the pipe line (C) to pressurize the tank (D), which contains a premixed solution of protein foam liquid in water. The solution is displaced from the tank by the air pressure and passes through the bottom outlet to the mixing unit (E) and the improver (F). Compressed air is also led through the pipe-line (G) to the mixing unit (E) and eventually to the foam improver (F) to provide the gas phase in the foam.

A detailed description of the various stages of the apparatus follows.

Air Compressor

Compressed air is provided in the foam generator by a 'Palouste' Air Compressor manufactured in 1952 by Turbomeca of France. This unit consists essentially of a single stage centrifugal compressor, part of the output of which is bled off for external use, and part is delivered to the combustion chamber and single-stage axial flow turbine to provide power to drive the oversize compressor.

The output from the compressor is 2 lb/sec of air at a temperature and pressure of 200°C and 35 to 40 lb/in² (gauge) respectively. Approximate

constructional data for the turbo-compressor is as follows:

Length - 42 in
Width - 19 in
Height - 20 in
Weight - 200 to 250 lb.

Solution tank

The solution tank has a capacity of 650 gallons and is designed to withstand a working pressure of 50 lb/sq.in at a temperature of 200°C. Protection from corrosion by the foam-making solution is afforded to the inside of the tank by a phenolic lining.

Mixing unit

As it was required that foams having expansions of up to 25 to 1 and critical shear stress values of up to about 1,000 dyn/cm² should be provided by the apparatus, intimate mixing of the foaming solution and air over a short pipe length (about 4 feet) was necessary.

Although some mixing will take place during foam formation in the improver unit (described later) it seems preferable to obtain a uniform mixture of the liquid and air before the formation of foam begins. Several methods of mixing, described briefly below, were examined, with varying success.

a) Velocity control device

It was thought that control of the velocities at which the liquid and air streams came together would enable optimum mixing to be obtained. This was achieved by the use of variable annular liquid and air outlets in the mixing unit, shown diagrammatically in Figure (2a).

b) Mixing unit using series of impinging jets

The principle of this device is to provide a series of impinging jets forming sheets of foaming solution at right angles to the flow of air, in order to assist the formation of bubbles. (Fig.2b). The liquid pressure being variable within a limited range only, provision was made for increasing the number of pairs of jets in use by selecting a suitable position of the piston P to give the liquid flow rate required for any chosen expansion.

c) Cone Spray Nozzle

The impinging jet assembly described above was replaced by the jet head assembly of a 100 g.p.m. capacity foam-making branchpipe. This device showed some promise of success and was later replaced by a cone spray nozzle which gave a similar spray pattern but would pass up to 250 g.p.m. of liquid.

In some cases the above devices were followed by various combinations of deflectors, and different forms of wire cage.

It was considered that the cone spray nozzle, followed by a peripheral gauze (described later), was the best method of mixing the foaming

solution and air, on the basis that this method generally produced foams having an expansion ratio of at least 10 per cent higher than the other methods examined.

The arrangement finally adopted is shown in Figure (2c). A proprietary cone spray nozzle is followed by two cylindrically shaped pieces of $\frac{3}{8}$ in diamond mesh expanded steel, 18 in long, one placed inside the other. The expanded metal deflectors have the effect of a series of annular peripheral deflectors which prevent the foaming solution clinging to the outer walls of the mixing chamber and force it to re-enter the main air stream to form bubbles.

Foam improver

The foam improver (Figure 3) consists of a number of gauzes of 14 or 28 mesh through which the foam passes. An increase in the number of gauzes used increases the critical shear stress or stiffness of the resulting foam. The improver is contained in a 2 ft long by 8 in diameter steel tube, the speedy removal or replacement of which is facilitated by the use of special, quick-acting couplings.

The foam is further "improved" by increasing the "internal" surface over which it passes, by passing the foam through a number of 2 ft lengths of 1 in bore steel tubing placed in the main 8 in diameter tube.

Monitor

As the expected maximum foam output from the generator was to be 4,000 to 5,000 g.p.m. two proprietary monitors each having a capacity of 2,500 g.p.m. (foam) were fitted to the apparatus. Initial trials showed that it was difficult to direct both monitors simultaneously without complex linkage, and the use of one of them was discontinued. One of the requirements of the apparatus was that its foam output could be varied between 300 gal/min and 4000-5000 gal/min, and the other monitor was therefore modified as follows, to meet this requirement. To ensure the same efflux velocity of the foam at various chosen rates in the above range, a series of nozzles, of different diameter, was made for attachment to the monitor, the appropriate nozzle being selected before each run. In most cases, the foam was projected 150 ft from the monitor, the measurement being taken at the mean range of the ground pattern.

Flow control and measurement

The air and liquid flows are controlled by a 6 in butterfly valve, J, and a 4 in diaphragm valve, H, respectively (Fig.1).

Flow quantities are indicated by single column mercury manometers (L, and M Fig.1) which measure the pressure drop across orifice plates placed in the air and liquid lines.

Flexible expansion joints

Three flexible expansion joints are fitted to the generator assembly to prevent damage due to flexing in the vehicle chassis or to undue thermal expansion, particularly in the air pipe line.

PERFORMANCE OF THE GENERATOR

Foams having the following range of properties were produced by the foam generator with a 6 per cent foaming solution:-

Liquid rate: 50 to 200 g.p.m.

Foam expansion: 5 to 18.

Critical shear stress: 150 to 1,500 dyn/cm².

Twenty-five per cent drainage time: 2 to 200 min.

The useful range of the foam generator was later extended by the use of a centrifugal pump in the liquid line (see Figure 1) which permitted all the air from the compressor to be used for the gas phase of the foam. The range of foam properties obtained with this method was as follows:-

Liquid rate: 50 to 280 g.p.m.

Foam expansion: 5 to 25.

Critical shear stress: 150 to 1,500 dyn/cm².

Twenty-five per cent drainage time: 2 to 200 min.

This method⁽²⁾ has previously been used experimentally by a British manufacturer of fire-fighting equipment.

Use of the centrifugal pump necessitated the incorporation of the valves 1 to 4 (Figure 1) in the apparatus. Valve 1 is closed and valve 2 open to allow atmospheric air to replace the liquid as it flows from the tank. Valve 3 is closed and valve 4 open to allow liquid to pass through the pump (H). When the pump (H) is not used, valve 2 is closed and valve 1 open and the liquid in the tank is displaced by air from the turbo-compressor (A). The pump (H) is by-passed by closing the valve 4 and opening valve 3.

As stated earlier in this report, the primary purpose of the gas turbine operated foam generator was to produce large quantities of foam having a wide range of physical properties, capable of being varied independently of one another. In practice this aim has been achieved to a large degree, and the apparatus is now being used in a series of experimental aircraft fires to determine the optimum values of the foam properties to achieve rapid fire control.

No prolonged attempt was possible to obtain the optimum design of the apparatus, as its development was conditioned by the need to achieve the desired experimental performance in a limited time. Some of the discarded methods of mixing the air and foaming solution clearly had promise of success had time been available for their development and they have therefore been included in the description. The limited development done so far has, however, shown that the basic principle of the apparatus is suitable for development into a practical design of foam-making appliance. The arrangement of a practical foam generator would be much simpler than that described in this note as the design requirement would be for one type of foam only. A higher foam output than that obtained with the present foam generator would be required in practice. Use of a turbo-compressor giving an air output of, say, twice that of the present engine would produce about 8,000 gal/min. of foam.

ACKNOWLEDGMENT

Thanks is due to Mr. R. Coasby and Mr. D. D. Richardson for their assistance with the experimental work.

REFERENCES

- (1) NASH, P. and FRENCH, R. J. Aircraft crash tenders. Brit. Pat. No. 967792.
- (2) CLIFFORD, W. J. Improvements in Foam-producing Apparatus. Brit. Pat. No. 715,124.

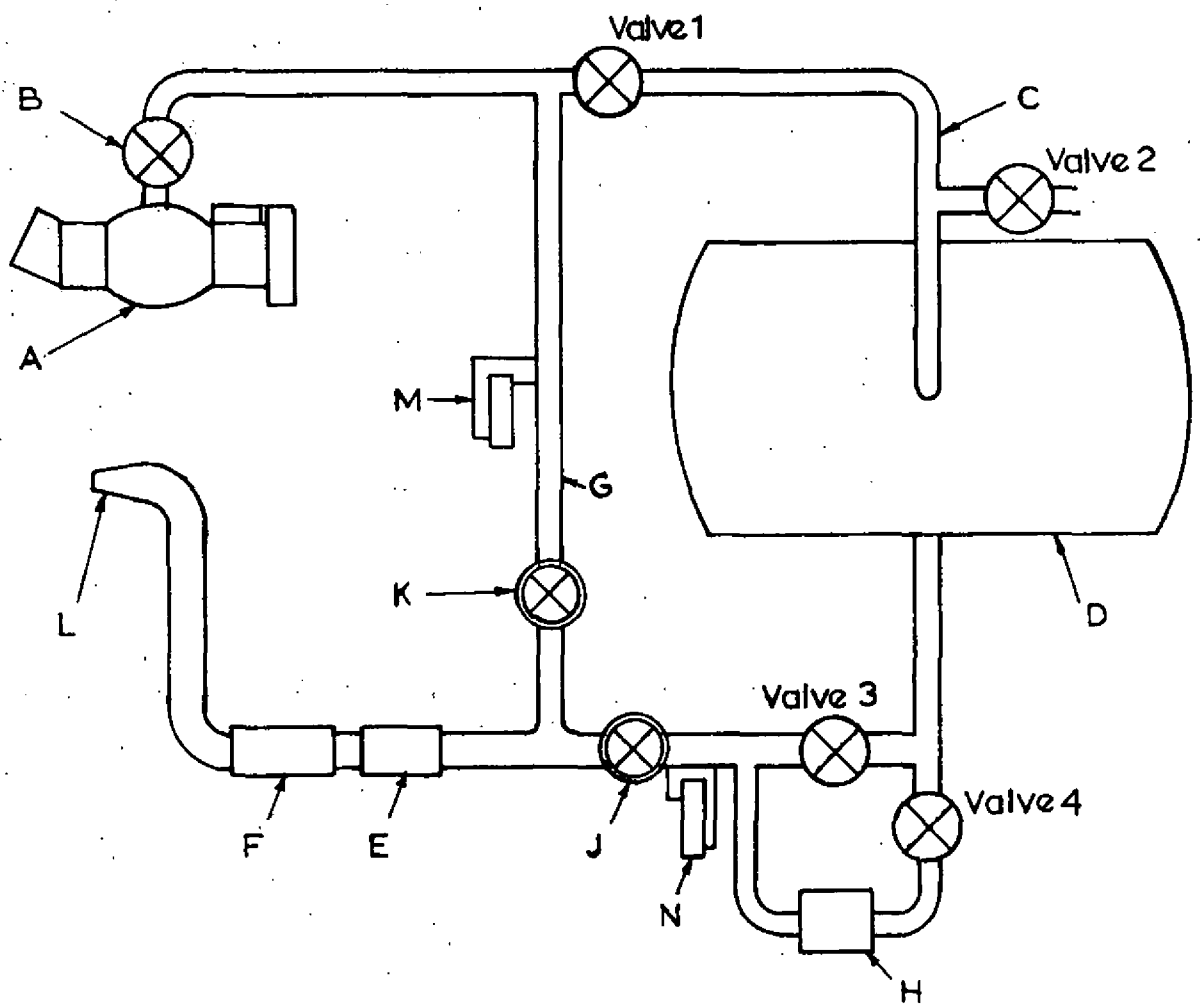

ITEM	DESCRIPTION
A	Turbo-compressor
B	Air spill valve
C	Air line to liquid tank
D	650 gal capacity liquid tank
E	Air/liquid mixing unit
F	Foam improver
G	Air line supplying gas phase in foam
H	Centrifugal pump
J	Liquid control valve
K	Air control valve
L	Monitor
M	Air flow meter
N	Liquid flow meter

FIG.1. DIAGRAMMATIC ARRANGEMENT OF FOAM GENERATOR

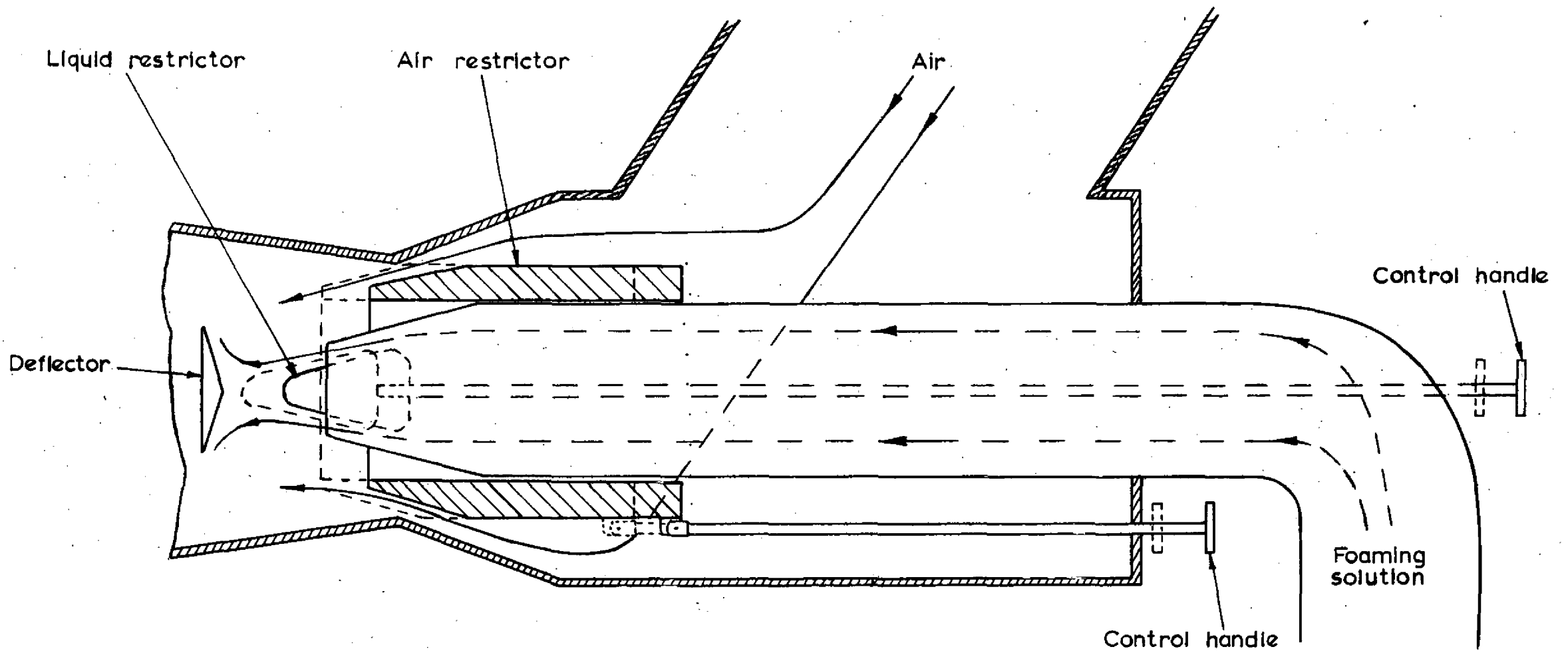

FIG.2a. VELOCITY CONTROL MIXING UNIT

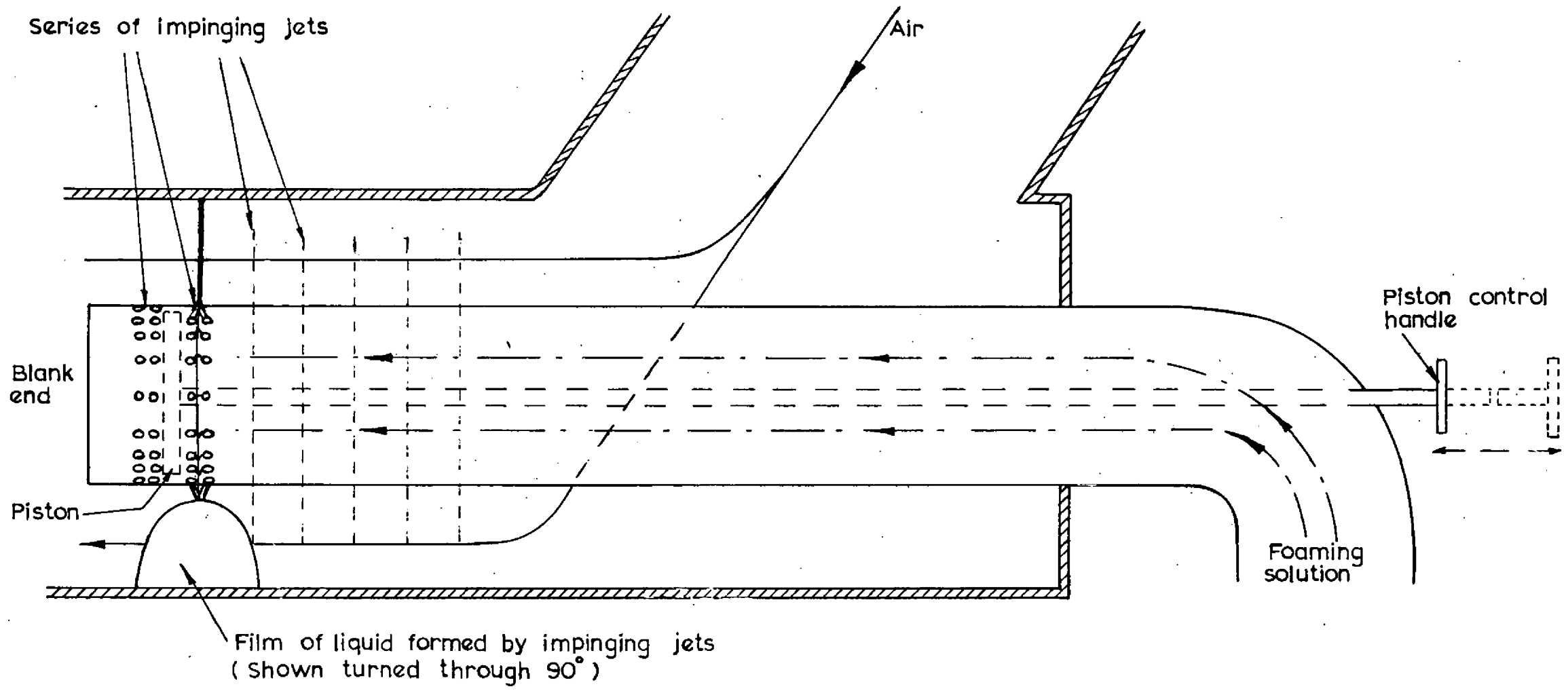

FIG.2b. MIXING UNIT USING SERIES OF IMPINGING JETS

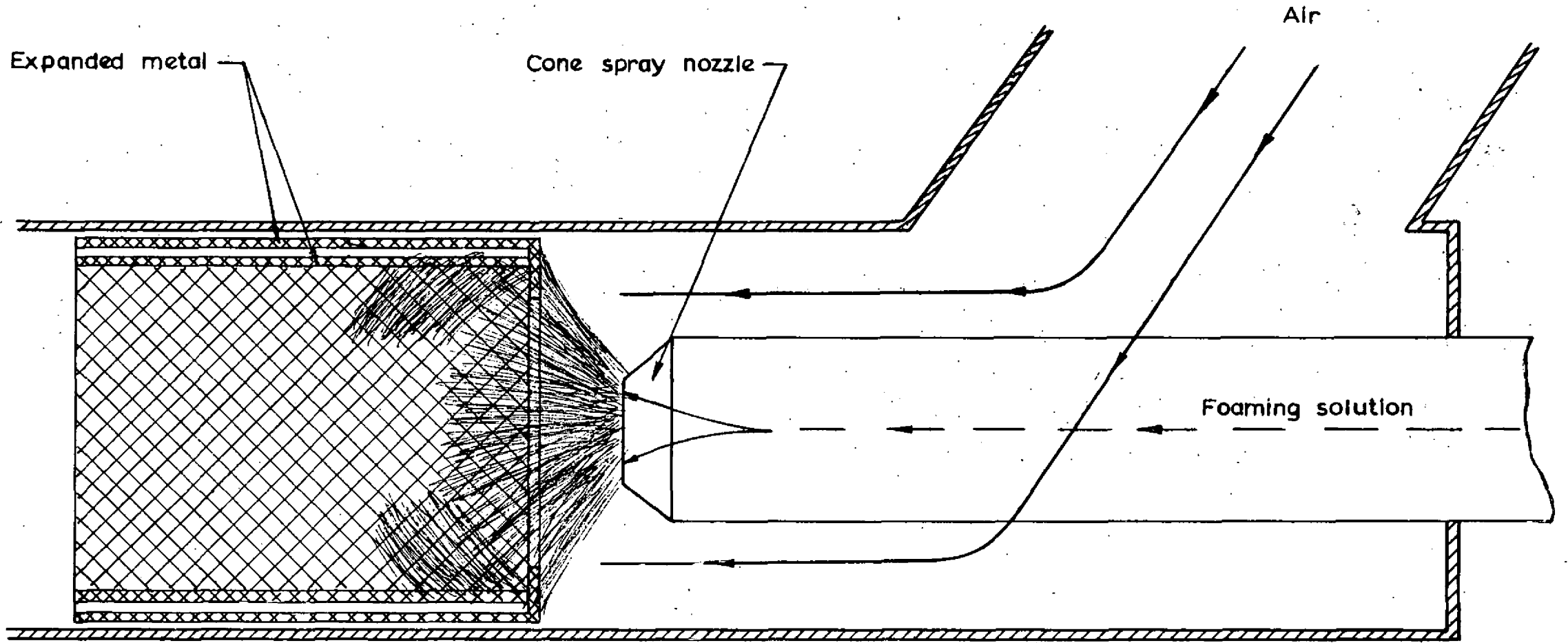

FIG.2c. FINAL ARRANGEMENT OF MIXING UNIT

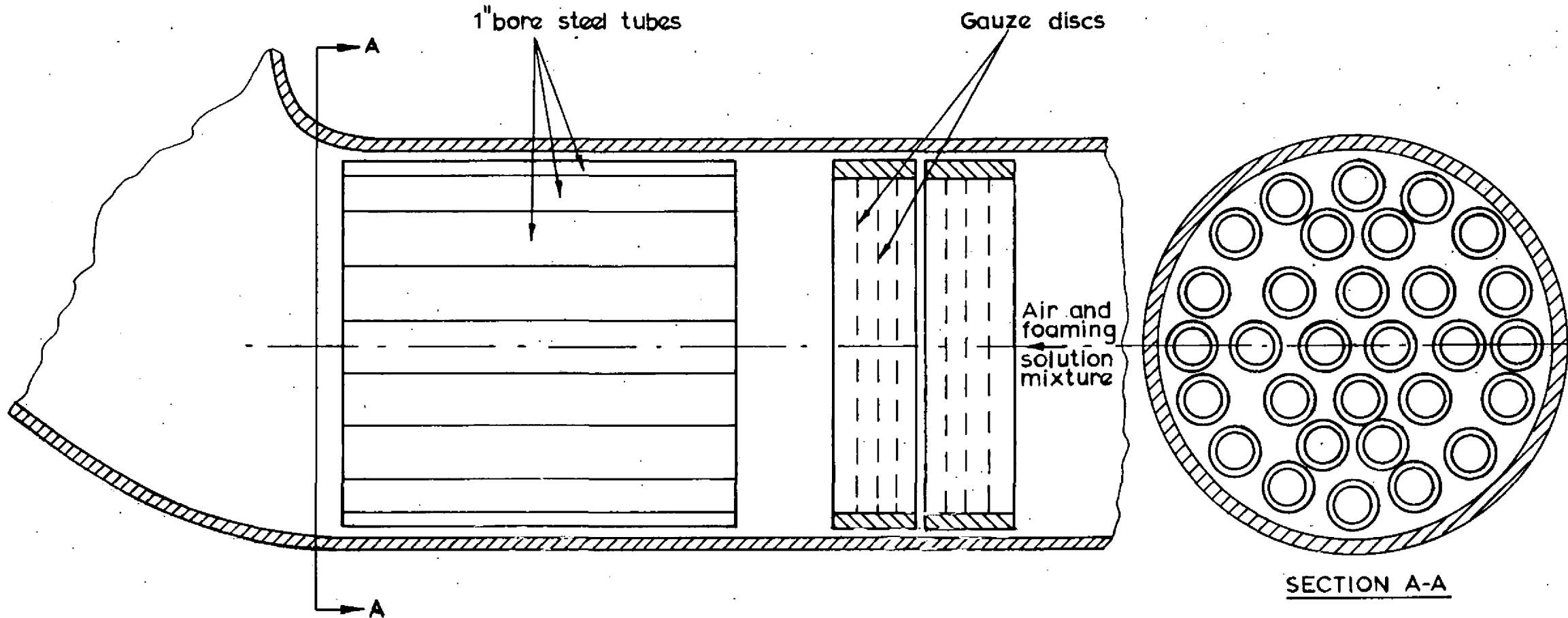
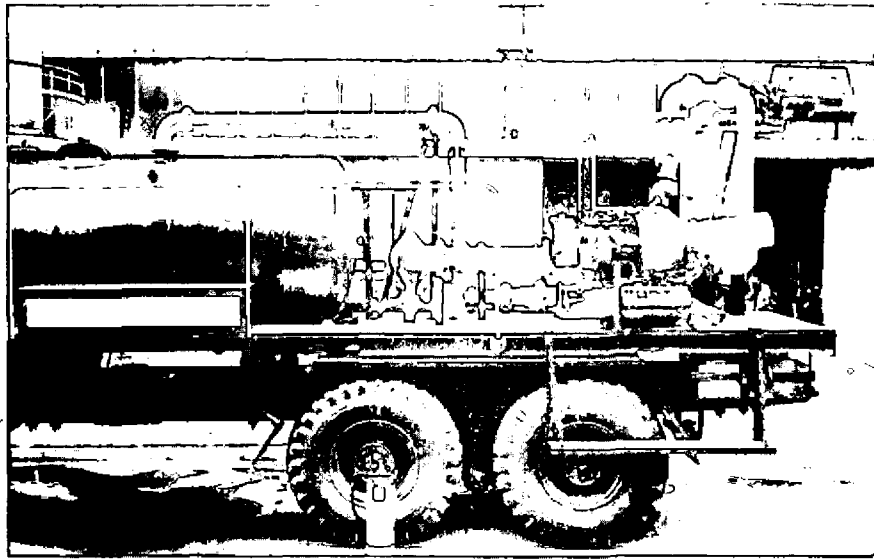
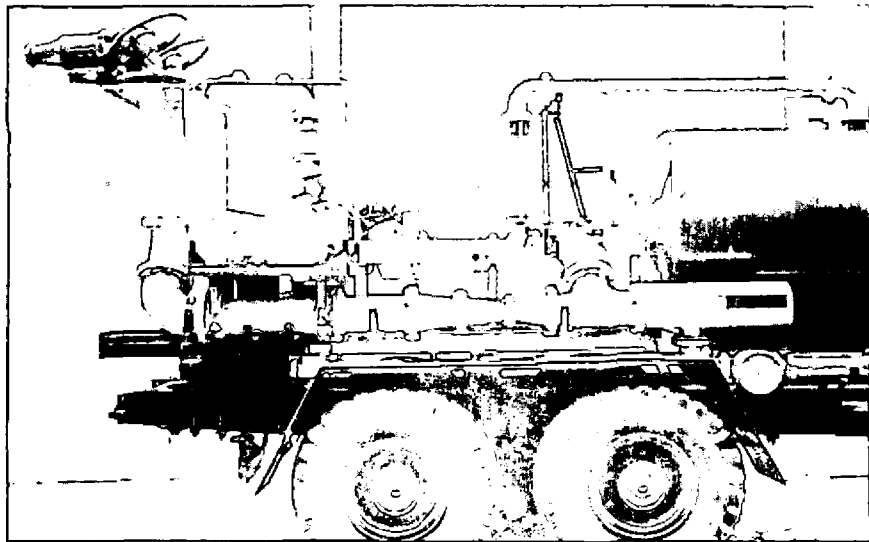

FIG.3. FOAM IMPROVER



(a)



(b)

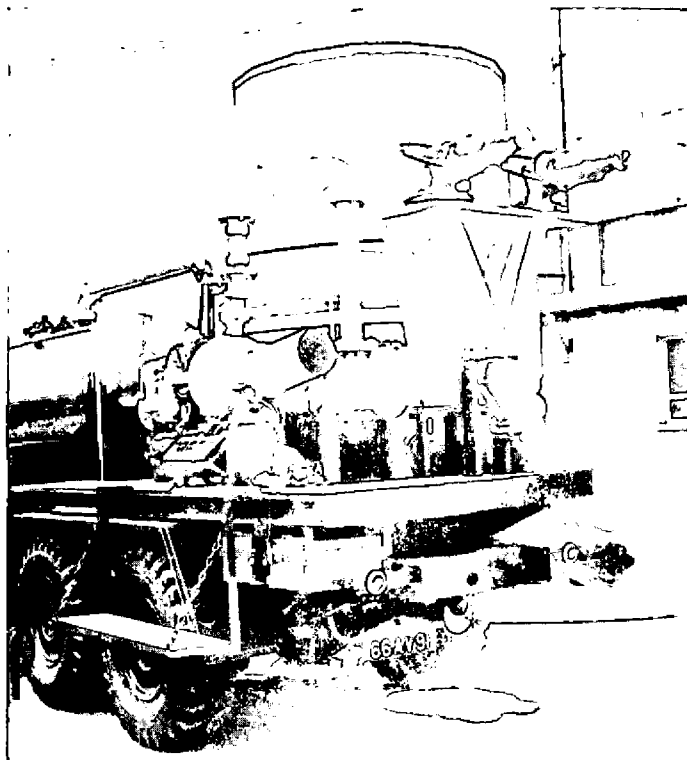

(c)



PLATE.2. APPLICATION OF FOAM TO FIRE AREA



