

LIBRARY REFERENCE ONLY

M.O.T. AND F.O.C.  
FIRE RESEARCH<sup>25/1</sup>  
ORGANIZATION  
REFERENCE LIBRARY<sup>1/67</sup>  
No. A99FR. N 638



# Fire Research Note

## No. 638

THE EXTINCTION OF PETROL AND SOLID FUEL FIRES  
WITH LIQUID NITROGEN

by

D. D. RICHARDSON

FIRE  
RESEARCH  
STATION

F.R. Note No. 638  
October, 1966.

**THE EXTINCTION OF PETROL AND SOLID FUEL FIRES  
WITH LIQUID NITROGEN**

by

D. D. Richardson

**SUMMARY**

This note describes an investigation of the performance of liquid nitrogen on petrol and wooden crib fires. It shows that liquid nitrogen is likely to be less effective than dry powder in the extinction of small petrol fires, but more effective than water in the extinction of small solid fuel fires.

**Crown copyright**

This report has not been published and should be considered as confidential advance information. No reference should be made to it in any publication without the written consent of the Director of Fire Research.

**MINISTRY OF TECHNOLOGY AND FIRE OFFICES' COMMITTEE  
JOINT FIRE RESEARCH ORGANIZATION**

# THE EXTINCTION OF PETROL AND SOLID FUEL FIRES WITH LIQUID NITROGEN

by

D. D. Richardson

## INTRODUCTION

The latent heats of vaporisation of liquid nitrogen and water are 50 cal/gm and 540 cal/gm respectively. If both agents are applied to a fire in which they are completely vaporised, the liquid nitrogen can therefore absorb only  $1/10$  the heat that an equal weight of water can absorb. If both agents are heated from their vaporising temperatures ( $100^{\circ}\text{C}$  and  $-196^{\circ}\text{C}$  for water and liquid nitrogen respectively) to the flame temperature, say  $1300^{\circ}\text{C}$ , water vapour will absorb about  $1\frac{3}{4}$  times the heat that nitrogen gas will absorb, i.e. 646 cal/gm for water against 379 cal/gm for nitrogen.

Liquid nitrogen is, however, far more likely to vaporise completely in a fire, particularly a small fire, than is water. Hence the above numerical advantage of water is unlikely to be realised, unless the conditions permit complete evaporation of the water. The residual water can also cause damage in addition to fire damage. A few tests have therefore been carried out, and are described in this note, to obtain some practical information on liquid nitrogen as an extinguishing agent particularly in comparison with water.

## EXPERIMENTAL METHOD

Liquid nitrogen was supplied from a vacuum insulated tank at a pressure of 15 to 20 lbf/in<sup>2</sup>, the weight of agent discharged being measured by a spring balance system in which the tank and contents were suspended.

The liquid nitrogen was discharged through a 10 ft length of flexible stainless steel hose to a thermally insulated hand-held nozzle, the diameter of which could be varied to give the desired rate of discharge of nitrogen.

To eliminate vaporisation of the liquid nitrogen along the hose line, it was necessary to discharge the liquid for up to 20 seconds before applying it to a fire. This allowed sufficient cooling of the hose and nozzle to prevent further evaporation in the hose itself, so that an unbroken jet of liquid nitrogen could be applied to the fire during the experiments.

## APPLICATION TO PETROL FIRES

The petrol fires were ignited in  $\frac{1}{2}$  in depth of narrow boiling point range petroleum, floating on a 1 in depth of water, in two rectangular steel trays giving free petrol surfaces of 2.25 ft<sup>2</sup> (1.5 ft x 1.5 ft) and 4.5 ft<sup>2</sup> (3.0 ft x 1.5 ft) respectively.

In five tests, the liquid nitrogen was applied to the fire by jet and in one test it was poured gently on to the fire from an open vessel.

A preburn time of about 30 seconds was allowed in each of the six fire tests before applying the liquid nitrogen to the fire. Rates of application of the nitrogen are given in Table 1.

#### APPLICATION TO WOODEN CRIB FIRES

The cribs were constructed of sticks of white pine wood, 36 in long x 1 in square, arranged in 24 layers of 7 sticks per layer, the successive layers being placed at right angles (Fig. 1).

In each of the four fire tests, the cribs were ignited by burning 150 ml of petrol in a  $4\frac{3}{8}$  in diameter metal tray, placed centrally beneath the crib. A 4 minute preburn was allowed for each crib before applying the liquid nitrogen, which was projected from the hose and nozzle into the crib, from one side only (Plates 3 and 4).

During two of the tests the oxygen concentration was measured near one corner of the crib, 18 in from the ground (Fig. 1).

For comparison, one test was made using water to extinguish the fire. Rates of application of nitrogen and water are given in Table 2.

#### RESULTS AND CONCLUSIONS

##### (a) Petrol fires (Table 1).

The liquid nitrogen extinguished the fires in all the six tests. In tests 1 and 2, on the smaller of the two trays ( $2.25 \text{ ft}^2$ ), extinction was achieved in 8 and 2 seconds respectively. Because of the ease of extinction in these two tests the larger tray ( $4.5 \text{ ft}^2$ ) was then used.

In tests 3 and 4, using a rate of application of 0.7 and 0.9 lb/s respectively, disturbance of the petrol by the jet of liquid nitrogen caused some of the burning petrol to splash out of the tray, so increasing the area and heat intensity of the fire (Plate 1). The extinction times for tests 3 and 4 were 30 and 15 seconds respectively.

The rate of application of liquid nitrogen was reduced to 0.12 lb/s in test 5 and the extinction time increased to 65 seconds. It appeared likely that the rate of application of 0.12 lb/s was approaching the "critical rate of application", defined as the rate below which the fire cannot be extinguished.

The  $2.25 \text{ ft}^2$  tray was used for test 6, where the liquid nitrogen was poured into the burning petrol in order to avoid undue disturbance of the fuel. The liquid nitrogen was vaporised by the fire and extinguished it in 18 seconds.

The residual liquid nitrogen left in the tray after extinction of the fire continued to "boil off", and during this time it was found difficult to re-ignite the petrol.

##### (b) Wooden crib fires (Table 2)

In each of the three crib fire tests the liquid nitrogen readily controlled and extinguished the fires.

In tests 7 and 8, the liquid nitrogen was applied for a period of time after flaming had ceased to prevent possible re-ignition of the cribs. For the third test, number 9, at the lowest rate of application, (0.27 lb/s), the liquid nitrogen was cut off at the instant when the flames were extinguished, but still no re-ignition of the crib occurred.

In the test with water (Test 10) the rate and time of application (0.33 lb/s for 60s) was the same as for the liquid nitrogen in Test 8. Control of the fire was noticeably longer than in Test 8, and after the 60 second discharge period small flickers of flame still persisted in the lower part of the crib. These flickers continued for a further 9 minutes and then died out.

The oxygen concentration measured near the crib in Tests 8 and 9, was found to be slightly below the normal value for air, i.e. 20.8 per cent.

In the petrol fire experiments no comparison was made between liquid nitrogen and the standard proprietary extinguishing agents (dry powder, vaporising liquids etc.). A comparison can be made, however, using results of previous experiments with dry powder made at the Joint Fire Research Organization.

Sodium bicarbonate dry powder will extinguish a 4.5 ft<sup>2</sup> area petrol fire at a rate of application of 0.3 lb/s in about 2 seconds, giving a total discharge of 0.6 lb of powder.

If the results of Test 4 are assumed to be the optimum values, it can be seen that liquid nitrogen, applied at a rate of 0.9 lb/s extinguished the petrol fire in 15 seconds, a total of 13.5 lb of liquid nitrogen.

From these comparative results it is concluded that, on a weight and extinction time basis, liquid nitrogen is far less efficient than dry powder in the extinction of petrol fires. Also, if the liquid nitrogen is applied to a petrol fire by jet application, it is possible that excessive disturbance of the fuel may increase the area and intensity of the fire.

Against solid fuel fires, liquid nitrogen may be more efficient, weight for weight, than water, without the attendant risk of water damage. The results from the crib fire tests showed that 20 lb of water was necessary to extinguish a fire, whereas only 4.9 lb of liquid nitrogen was needed to extinguish the same fire.

TABLE 1

## Fires in Narrow Boiling Point Range Petrol

Test No.	Fire area (ft <sup>2</sup> )	Liquid nitrogen			Extinction time (s)	Quantity of liquid nitrogen applied to fire (lb)	Remarks
		Nozzle diameter (in)	Approximate length of jet (ft)	Rate of discharge (lb/s)			
1	2.25 (1.5 ft x 1.5 ft)	0.625	1	Approx 0.5	8	4.0	-
2	"	1.093	3	0.8	2	1.6	-
3	4.5 (3.0 ft x 1.5 ft)	"	3	0.7 to 0.8	30	24.0	Liquid nitrogen jet splashed petrol out of tray, 4 or 5 ft <sup>2</sup> area fire burning outside of tray.
4	"	"	3	0.9	15	13.5	As above (Plate 1)
5	"	0.469	1 to 2	0.12	65	7.8	Approaching the critical rate of application.
6	2.25	3 litres of liquid nitrogen poured into burning petrol.			18	Approx. 5.0	The liquid nitrogen continued to "boil off" in the petrol, during which time it was difficult to re-ignite the fuel.

TABLE 2

## Fire in Wooden Cribs

Test No.	Nozzle diameter (in)	Extinguishing agent	Rate of discharge (lb/s)	Extinction time (Flames Out) (s)	Quantity of agent applied to fire (lb)	Oxygen concentration (per cent)	Remarks
7	1.093	Liquid nitrogen	0.8	5 to 10	32	-	Wood continued to crackle until 20-30 seconds. Agent applied for 40 seconds. No re-ignition of crib.
8	0.469	"	0.33	20	20	19.5	Agent applied for 60 seconds. No re-ignition of crib (Plates 2, 3, 4 and 5).
9	"	"	0.27	18	4.9	20.5	Agent applied for 18 seconds. No re-ignition of crib.
10	0.25	Water jet	0.33	-	20	-	Water applied for 60s, 3 or 4 small flickers of flame in lower half of crib after water application ceased. After a further 8 minutes only one small flicker remaining. Complete extinction after 10 minutes.

PAINT



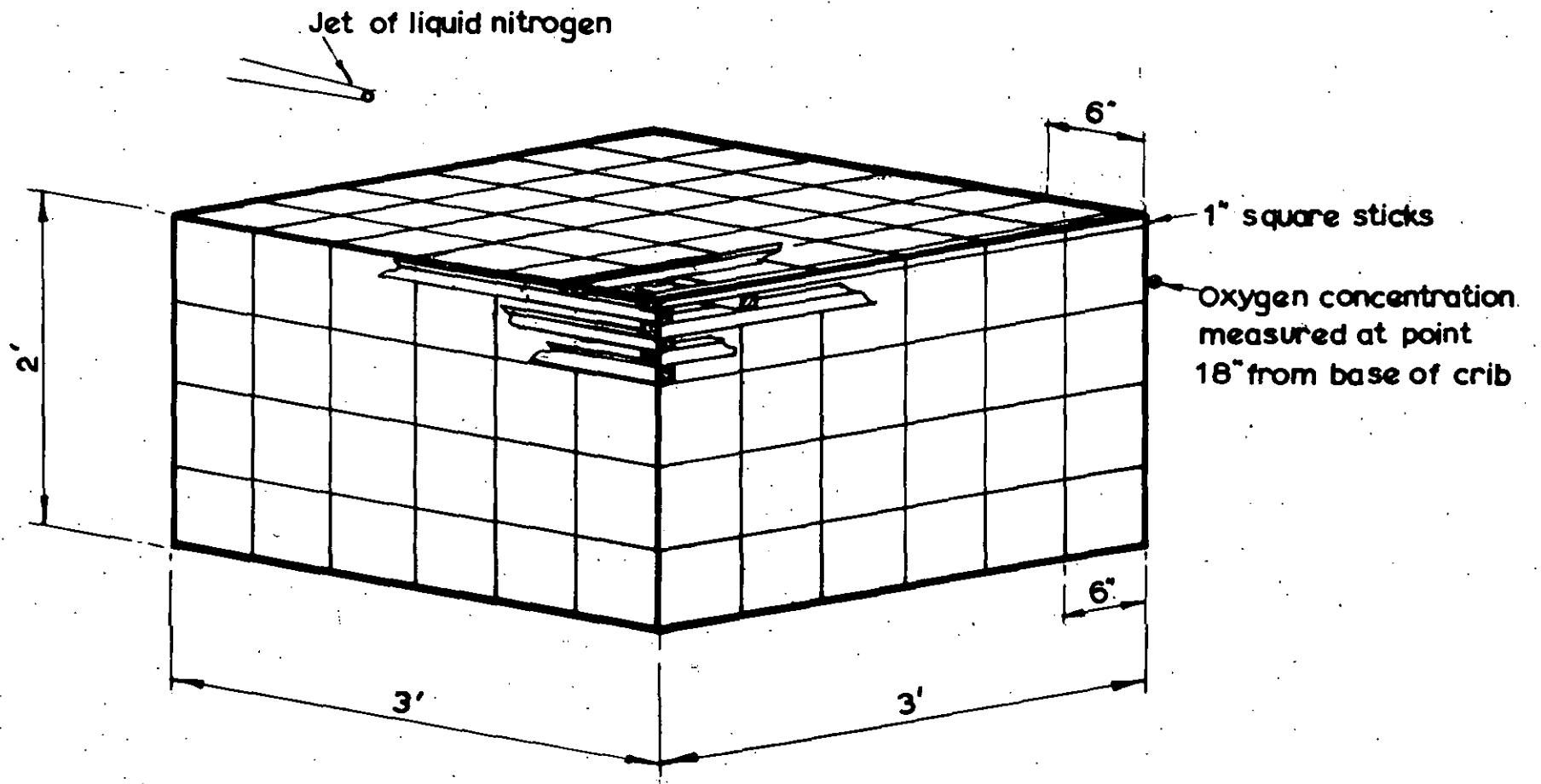
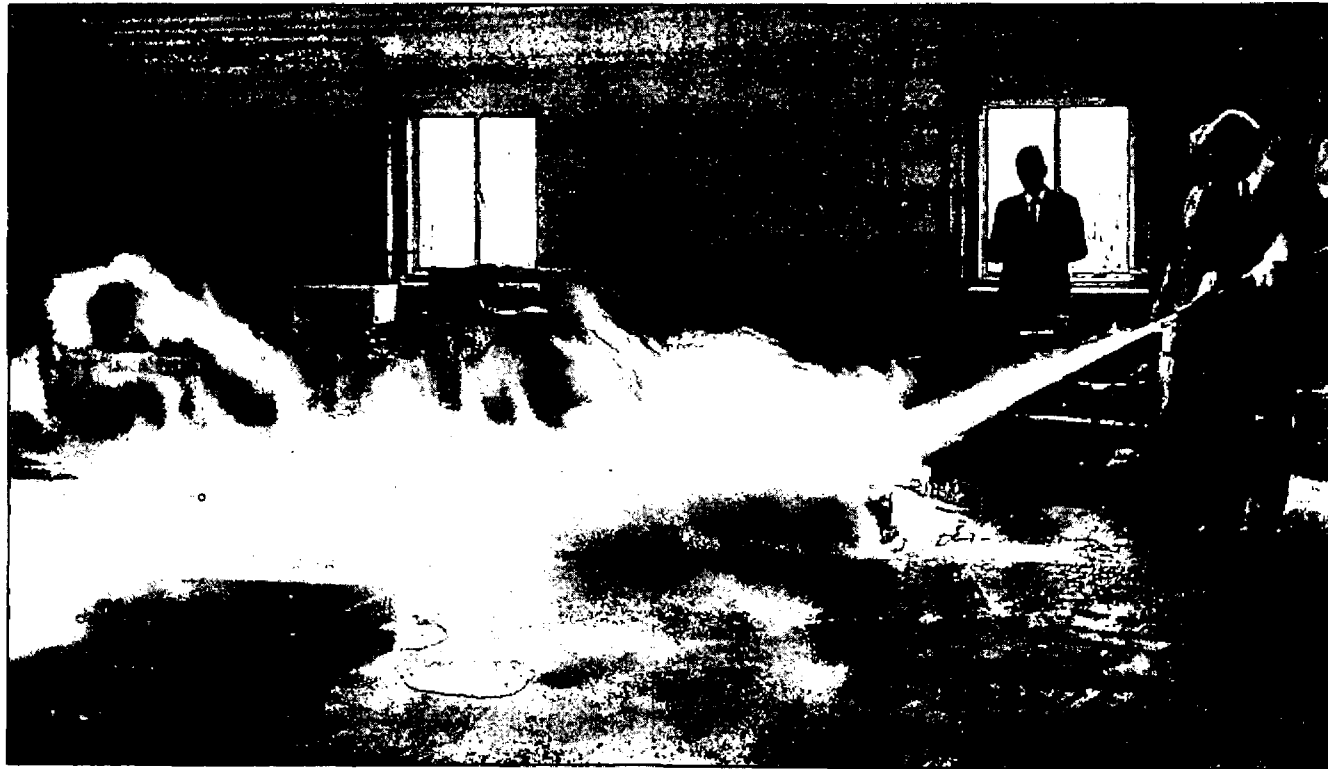

FIG.1. DETAIL OF WOODEN CRIB, SHOWING POSITION OF JET AND AIR SAMPLING POINT



TEST 4 . Ten seconds after commencement of  
liquid nitrogen into petrol fire

PLATE 1



TEST 8 Condition of crib fire after 4 min preburn

PLATE 2



TEST 8 Crib fire after 3 second discharge of nitrogen

PLATE 3



TEST 8 Crib fire extinguished after 20 seconds discharge

PLATE 4



TEST 8 Condition of crib after discharge

PLATE 5

2

.

.

.

3

4

5

.

6