

LIBRARY REFERENCE ONLY

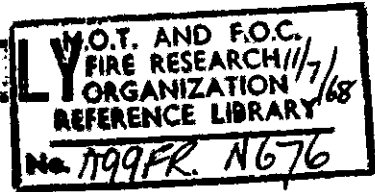

Fire Research Note

No. 676

FLAME ARRESTERS AS BARRIERS AGAINST
HOT METAL PARTICLES

by

Z. W. ROGOWSKI

January 1968

FIRE
RESEARCH
STATION

FLAME ARRESTERS AS BARRIERS AGAINST HOT METAL PARTICLES

by

Z. W. Rogowski

Summary

Crimped ribbon flame arresters, when exposed to arc discharges obtained by fusing copper wires, prevented ignition of flammable gas on the opposite side of the arrester, by the hot metal particles penetrating the arrester apertures. However particles produced by fusing aluminium wires remained incandive after penetrating the arrester apertures. These particles reacted with the surrounding oxygen, thus maintaining their high temperature.

If the fusing of the wires was accompanied by the explosion of propane-air mixture, the expanding gases assisted the passage of small incandive particles through the apertures of the arrester.

The particles produced by fusing of aluminium wires may however be safely contained within reinforced insulating sleeving, providing it was strong enough to withstand the pressures and the temperatures generated during fusing of such wires.

Crown copyright

This report has not been published and should be considered as confidential advance information. No reference should be made to it in any publication without the written consent of the Director of Fire Research.

FLAME ARRESTERS AS BARRIERS AGAINST HOT METAL PARTICLES

by

Z. W. Rogowski

Introduction

Laboratory investigations have been carried out in the past exploring the possibility of using flame arresters for the protection of electrical and other equipment used in flammable atmospheres^{1, 2}. The results of these investigations indicated that the flame arresters were capable of relieving the explosions without igniting the external explosive gas when applied to vessels of various volumes up to 85 l, which was the largest tested. Past work has been mainly concerned with obtaining the relation between arrester area and the maximum explosion pressure under a variety of conditions.

The present investigation evaluates the performance of crimped ribbon arresters when these are exposed to electrical arc discharges of various energies, obtained by fusing copper and aluminium wires with direct currents, in atmospheres of propane and air. Such discharges might be obtained from an electrical fault in the wiring of equipment protected with flame arresters.

Apparatus and materials

Explosion vessel

A 9 l mild steel cubical vessel was used for the experiments. This had detachable aluminium alloy (B.S. HP 30) covers, with central venting holes, for mounting flame arresters of diameters 2.9 and 11 cm. Several bosses were provided for introducing the power supply and the insertion of gauges. This vessel rested within a 440 l cubical enclosure, one side of which was provided with a relief vent sealed with 0.0038 cm thick polyethylene film.

Flame arresters

Two different types of flame arrester were used; both were made of crimped ribbon. Commercial flame arresters were made from cupronickel ribbon; one layer of crimped ribbon together with a layer of straight ribbon were wound round a central core and then cased into a length of brass tubing. These arresters are designated in this paper as type a. Non commercial flame arresters were of incoloy alloy and were made from alternate lengths of straight and crimped ribbon packed together. The layers of ribbon were joined by welds on both sides of the arrester, outside the working area. Both types of arrester were mounted in an appropriate vessel cover with a central vent of 2.9 or 11 cm diameter for non commercial arresters, and 11 cm diameter for commercial arresters. Table 1 shows details of the arresters used in the experiments.

Table 1
Details of the arresters

Diameter of arrester cm	Type	Ribbon metal	Ribbon thickness cm	Crimp height cm	Length of aperture cm
11.0	a	Cupronickel	0.0063	0.11	3.8
11.0	b	Incoloy alloy	0.0185	0.051	2.5
2.7	b	Incoloy alloy	0.0185	0.051	2.5

Pressure measuring apparatus

In some experiments explosion pressures were determined by the use of a quartz piezo-gauge. This was situated in one wall of the explosion vessel.

Power source and power regulating unit

Twenty lead-acid accumulators were used as a power source at 250 V. With these it would be possible to obtain for a short time a maximum current of 1700 A. with no external resistance. Fig. 1 shows the diagram of the circuit used.

Resistance A could be adjusted to obtain the desired prospective current. The prospective current is that which would flow in the circuit if the fuse wire were replaced by a resistance of negligible value, and which did not fuse. Contactor B was actuated by a relay to make the circuit. A double beam oscilloscope measured the voltage across the fuse wire C and the current across the shunt D. The traces of both current and voltage were obtained for all the wires with prospective currents of 330 and 1200 A.

Fig. 2 shows a photograph of the power supply and the control gear. E indicates accumulators, and A is the variable resistance; B is the contactor with an actuating solenoid through an intermediate relay, in order to reduce interference on the cathode ray oscilloscope.

Wires

10 cm lengths of tinned copper or aluminium wires of 0.019, 0.025, 0.046, 0.056 and 0.071 cm diameter (36, 33, 26, 24 and 22 S.W.G.) were fused. These were mounted in such a way that with 11 cm diameter arresters a 5 cm length of wire was 1.3 cm away and parallel with the arrester; with the 2.7 cm diameter arresters, 2.7 cm length of wire was 1.3 cm away and parallel with the arrester. In a few tests the whole length of the wire was 15 cm away and parallel with the arrester.

Shields for arresting the metal particles

Attempts were made to arrest the aluminium particles before they reached the arrester apertures. Mild steel shield, 0.3 cm thick, of diameter 16 cm was mounted below the 11 cm vent. Fig. 3 shows the method of mounting; the letters A, B, C and D indicate various positions of the fuse wire when used with and without the shield.

Photographs of the incandescent particles

With fuse wires of various diameters, particles emerging from the arrester were photographed on still and revolving drum cameras. Both of these cameras gave photographs showing the trajectories of the incandescent particles. These experiments were carried out with the explosion vessel filled with air or with the propane-air mixture.

Procedure

The explosion vessel fitted with the appropriate arrester and fuse wire was placed inside the 440 l enclosure fitted with the polyethylene diaphragm. Both vessels were then charged with a 4 per cent propane-air mixture; the volume of gas mixture passed was equal to ten volumes of the large enclosure. The fusing circuit was then made and if ignition occurred in the outer enclosure it vented by rupturing the polyethylene diaphragm. If there was no ignition the mixture was disposed of by igniting it subsequently with an electric spark. When photographs of fused particles were taken only the explosion vessel was filled with the propane-air mixture.

Results

Characteristics of current and voltage during fusing of copper and aluminium wires.

Fig. 4 shows the record of voltage and current while fusing a copper wire. Soon after making the circuit the current rose to the peak value A and then slightly declined to B. During this period the voltage across the wire rose steadily to C. Both traces during this period are represented by solid lines. At point B the current commenced to decline rapidly until it reached zero, at the same time the voltage rose and with some wires exceeded for a short time the open circuit value. The traces during this period were represented by a broken line and this was accepted as the arcing period. With thicker wires the maximum current attained the value of the prospective current; with thinner wires, however, this value was never reached.

With the thicker aluminium wires the period throughout which the current declined was much longer than with copper wires of the same thickness. Figs. 5 and 6 show the arc energies in joules plotted against the cross sectional area of the wire for the prospective currents of 330 and 1200 A respectively. The prolonged arcing periods occurred wherever aluminium wires showed higher arc energies than the copper.

Performance of the arresters with fused aluminium wires

Fig. 7 A and B shows the probability of ignition of the external mixture with wires of various diameters in position A (Fig. 3) with prospective currents of 330 and 1200 A respectively. The probability of ignition is higher with the larger prospective current but for both prospective currents the thinnest and thickest wires gave highest number of ignitions, with the exception of 0.019 cm diameter (36 S.W.G.) wire at a prospective current of 330 A.

Fig. 7 C and D shows the probability of ignition with 0.019 and 0.025 cm diameter (36 and 33 S.W.G.) wires with prospective currents of 330 and 1200 A respectively, with the wires in position D. The histograms show that moving the wire away from the arrester considerably reduced the probability of ignition with both low and high prospective currents; with the thinnest wire, however, the probability of ignition was larger with the smaller prospective current. The tests with the 330 A prospective current were repeated using arrester b, of 11 cm diameter, in position A. The results are shown in Fig. 8 and in all tests the explosions were transmitted.

Fig. 9 A shows the probability of ignition by a wire 0.019 cm diameter (36 S.W.G.), with a protective shield, using a prospective current of 330 A. The shield reduced the probability of ignition to 0.2. The tests were repeated with the shield smeared with silicone grease to arrest the particles, which could otherwise bounce off the shield. The presence of grease made no difference to the probability of ignition (Fig. 9B). Fig. 9D and E show the probability of ignition with the 0.019 cm (36 S.W.G.) and 0.025 cm diameter (33 S.W.G.) aluminium wires, with the shield present, but with the wires in position C. The probability of gas ignition with both wires was 0.1. When the 0.025 cm diameter (33 S.W.G.) wire was moved to position D there was no ignition (Fig. 9F).

Performance of the arresters with fused copper wires

Figs. 10 A and B shows the probability of explosion transmission with copper wires of various diameters in position A (Fig. 3), using prospective currents of 650 and 1200 A, with the arrester of type a. There was no transmission. Fig. 10 C illustrates the probability of ignition with copper wires of various diameters in position A fused with a prospective current of 1200 A with an arrester of type b (2.7 cm diameter). With thicker wires some transmission occurred. Fig. 10 D shows the results of similar experiments, but with the aluminium cover lined in the vicinity of the arrester with nickel foil. No transmission occurred in these tests when wires of 0.056 cm diameter (24 S.W.G.) and 0.071 cm diameter (22 S.W.G.) were used.

Photographic evidence

All the photographs obtained with a still camera showed traces of incandescent metal particles coming from the arrester apertures. These particles were free to travel over a distance of 39 cm before colliding with the roof of the 440 l outer enclosure. In no tests in which photographs were taken did this enclosure hold a flammable mixture, and when the inner vessel contained flammable mixture, this is indicated. Fig. 11A shows the traces of particles of aluminium wire 0.07 cm diameter (22 S.W.G.) emerging from the type a arrester. The wire was fused with a prospective current of 330 A while in position A. The bright region visible above the arrester is caused by arcing which occurred between the wire and arrester ribbon. Three incandescent particles are visible on this photograph. These travelled a distance of a few centimetres and then decelerated to fall under gravity. The photographs obtained when this experiment was twice repeated showed particles barely rising above the arrester surface. Fig. 11 B shows a photograph of a similar experiment with the 9 l vessel filled with 4 per cent propane-air mixture; a large number of incandescent particles penetrated the arrester. Most of the particles struck the ceiling of the outer enclosure and were deflected to the horizontal direction. Fig. 12A shows the traces of particles produced by a 0.07 cm diameter (22 S.W.G.) aluminium wire, in position A, fused with a prospective current of 1200 A. The arrester of type a was used. Several particle traces were recorded and these burned out while travelling upwards or when falling by gravity after deceleration. Fig. 12B shows the photograph of a similar experiment but with the 9 l vessel filled with the propane-air mixture. A large number of particles is visible and the majority of these impacted the roof of the outer enclosure. Fig. 12C shows a further experiment with a shield present and the wire at position B. There were a relatively large number of particle traces and although most of these impacted the roof, they produced very faint traces both before and after impact.

These experiments were repeated with 0.025 cm diameter (33 S.W.G.) aluminium wire. The photographs obtained were similar to those with the 0.071 cm diameter (22 S.W.G.) wire but the traces were less bright and fewer particles were evident in corresponding tests.

To test further whether gaseous explosion assisted the transmission of the particles, four experiments were carried out with the 9 l explosion vessel filled with the 4 per cent propane-air mixture. Aluminium wire 0.019 cm diameter (36 S.W.G.) was fused with a prospective current of 330 A. In the first test no particles were recorded; in three further tests, however, particles were photographed. Fig. 13 shows one photograph on which the particle traces, of greatly differing intensity, are visible. The bright particles apparently fragmented on impact with the roof of the outer enclosure.

Fig. 14 shows a photograph of particles of copper wire 0.07 cm diameter (22 S.W.G.) placed in position A and with the type a arrester. This wire was fused with a prospective current of 1200 A and no propane-air mixture was present. Four traces of particles are visible; these rose a few centimetres above the arrester, decelerated and fell by gravity. One particle left a trace which is only visible at the peak of its flight. Fig. 15 A and B show photographs of the traces obtained with the same wire in the same position but with the 9 l vessel containing a 4 per cent propane-air mixture. A 2.7 cm diameter type b arrester was used and the aluminium cover holding the arrester was lined with nickel foil for the test recorded at Fig. 15A. The photographs showed that in both tests most of the particles impacted the roof of the enclosure and gave faint traces, with the exception of one bright particle emitted from the arrester while the cover was unlined, Fig. 15B.

The maximum velocities of aluminium particles are shown in Table 2. These were calculated from drum-camera traces, and were considerably higher in tests when the explosion vessel contained a flammable mixture. The velocities also increased with the prospective current. The effect of wire diameter was somewhat varied but generally the increase in diameter led to increase in the maximum particle velocity. In all tests where the explosion vessel contained air the particles decelerated throughout their flight. When, however, the explosion vessel was filled with 4 per cent propane-air mixture, the great majority of particles accelerated after entrainment in the moving gases.

Fig. 16 shows the drum-camera record of traces of particles produced by fusing a 0.07 cm diameter (22 S.W.G.) aluminium wire with a prospective current of 1200 A, and with the explosion vessel containing air. All particles evidently decelerated throughout their flight.

Fig. 17 shows the photograph of the same experiment with the exception that the explosion vessel was filled with the propane-air mixture; the behaviour of the particles was entirely different. The particles initially ejected (A) decelerated at the beginning of their flight, they subsequently accelerated and finally decelerated again before impacting the roof of the enclosure. Most particles ejected after point B accelerated throughout their flight. Other drum-camera records indicated that with a given wire and prospective current the time over which the ejection of particles took place was longer in experiments where gaseous explosion followed the fusing of the wire. The time during which the particles burnt varied from 10 m sec to 150 m sec. Thin wires produced particles of shorter duration and for a given particle velocity gave much fainter traces.

Table 2

Maximum velocities of particles produced by fusing aluminium wires

Diameter of wire cm (S.W.G.)	Contents of vessel	Maximum particle velocity m/sec	Prospective current A
0.071 (22)	Air	3	330
	4 per cent propane/air	30	
	Air	55	1200
	4 per cent propane/air	76	
0.025 (33)	Air	3	330
	4 per cent propane/air	49	
	Air	18	1200
	4 per cent propane/air	73	

Maximum explosion pressures

Table 3 shows the maximum explosion pressures obtained while igniting the flammable gas with aluminium and copper wires of 0.019 cm (33 S.W.G.) and 0.07 cm diameter (22 S.W.G.), at prospective currents of 330 and 1200 A, with 11 and 2.7 cm diameter arresters. In some experiments with the 11 cm diameter arrester a shield screening the arrester was inserted. The corresponding pressures obtained with an inductive spark across a 1 mm gap are shown for comparison. The maximum explosion pressures obtained with ignition by fused wire increased with the increase of wire diameter but decreased with the increase of prospective current. The insertion of the shield doubled the maximum pressure measured with no shield. With the 2.7 cm diameter arrester the maximum explosion pressures obtained with fused wires and with an inductive spark did not differ greatly. On the other hand pressures obtained with an 11 cm diameter arrester, using fused wire as an ignition source, were lower than corresponding pressures obtained with spark ignition. Direct comparison was not possible as the maximum explosion pressure with spark ignition was affected by acoustic vibrations; if these vibrations were absent the maximum explosion pressure would not exceed 0.04 at (0.15 lbf/in²).

Attempts were made to contain the fragmented wire inside insulating sleeving having both ends clipped. Various materials were tested and the results are summarized in Table 4. In the majority of the tests where the explosion was transmitted through the arrester the sleeve burst, but with some glass fibre sleeves, the hot aluminium particles penetrated the fabric without fracturing it. When glass fibre sleeves coated with PVC, or terylene sleeves, were used the ends of the wire were joined to 3 mm diameter copper electrodes which were attached to the ends of the sleeves with an epoxy resin. Wire mounted in this way in a polyvinyl chloride - glass fibre sleeve did not fracture the sleeve, and did not ignite the surrounding flammable gas. A terylene sleeve however was fractured in one test out of eight and the gas outside the arrester was ignited.

Discussion

Mechanism of fusing wires with an electric current

The disruption of wires by electric currents is well understood. With currents of similar magnitude to those used in this work, the disruption of the wire occurs in two distinct stages. Initially the applied electric energy is spent on heating the wire element. While this occurs there is considerable magnetic pinch effect, and the metal may reach a temperature considerably higher than the melting point before the breaks in the wire are formed. At this stage arcs are established and persist until the wire element is destroyed by fragmentation and vaporization and the gaps are wide enough to extinguish the arcs. The size and velocity of particles depend on the arc energy, the thickness and the length of wire. Greater arc energies tend to

Table 3

Comparison of the maximum explosion pressures obtained when igniting 4 per cent propane-air flammable mixtures by fuse wires and an inductive spark

Arrester type and diameter	Wire metal	Wire diameter cm (S.W.G.)	Prospective current A	Pressure at (lb/in ²)		Maximum pressure with an inductive spark 5 cm below arrester at (lb/in ²)
				Wire position A	Wire position B with shield	
a 11 cm	Aluminium	0.019 (33)	1200	0.08 (1.2)	0.19 (2.8)	0.15 (2.2)
		0.070 (22)	1200	0.12 (1.7)	0.22 (3.2)	
		0.019 (33)	330	0.04 (0.6)	0.10 (1.5)	
		0.070 (22)	330	0.06 (0.9)	0.07 (1.0)	
b 2.7 cm	Copper	0.019 (33)	1200	1.25 (18.5)	n.d.	1.46 (21.5)
		0.07 (22)	1200	1.31 (19.3)	n.d.	
		0.019 (33)	330	1.44 (21.2)	n.d.	
		0.07 (22)	330	1.77 (26.0)	n.d.	

n.d. not determined

Table 4

Summary of tests with fused aluminium wires
protected by insulating sleeving

Prospective current 1200 A

(a) Ends of insulating sleeving clipped

Diameter of wire mm (S.W.G.)	Bore of sleeving mm	Wall thickness mm	Sleeving material	Explosion transmitted number of tests	Explosion contained number of tests
0.19 (36)	0.5	0.5	P.V.C.	4	5
0.71 (22)	0.5	0.5	P.V.C.	3	3
0.19 (36)	1.5	0.5	Woven glass	1	11
0.71 (22)	2.0	0.5	Woven glass	0	1
0.19 (36)	2.0	n.d.	Woven glass	0	10
0.71 (22)	2.0	n.d.	Woven glass	3	5

(b) Ends of insulating sleeving sealed with epoxy resin

0.71 (22)	2	n.d.	Varnished woven glass	1	10
0.71 (22)	2	1	Woven glass P.V.C. covered	0	10
0.71 (22)	2	n.d.	Varnished woven terylene	1	7

n.d. not determined.

p.v.c. polyvinyl chloride.

produce smaller particles travelling at higher velocities; increase in wire thickness has the opposite effect. With short wires the arc energy attains high values before the failure of the element takes place. As the length of wire is increased, the arc energy decreases but it cannot be less than the inductive energy stored in the circuit. The increase in length causes the energy per unit length of wire to diminish, thus reducing the corresponding stresses on the wire.

Direct current may produce arcs of longer duration than alternating current. With the latter, arcing may only occur during part of half the cycle, moreover within that period voltage fluctuates. For these reasons tests with direct current may be expected to produce arc energies at least equal or greater than alternating current of the same R.M.S value.

Behaviour of metal particles after disruption of the wire

There are distinct differences in the behaviour of hot aluminium and copper particles. The former, if their temperature is sufficiently elevated, will react vigorously with oxygen in a variety of atmospheres and, since this reaction is highly exothermic, high temperatures are attained. Copper, on the other hand, reacts more slowly and the reaction results in low energy emissions.

The ignition and burning of aluminium wires has been studied extensively and a summary of the more recent work has been published³. Pure aluminium in the form of wires or large particles ignites at a temperature of 2300°K , this being the melting point of alumina. Such a high temperature is necessary to disrupt the protective coat of oxide in order to expose the underlying metal to the reactants. Certain modifications to the surface of the metal may, however, considerably lower the ignition temperature. Several combustion modes were put forward; all these suggest combustion of vaporized aluminium very close to the surface of the metal. The temperature in the gaseous reaction zone of the metal has been measured³ and is said to be not less than 3500°K and possibly reaching 3800°K . Single aluminium particles injected into a flame will not ignite unless the temperature of the flame

exceeds 2318°K^3 . Thus the 4 per cent propane-air mixture would not ignite wires used in these experiments. Observations made during the tests described in this work confirmed this and even the thinnest wire would remain intact after being exposed to such an explosion. This, however, would not apply to smaller wires or particles, which can be ignited at much lower temperatures by different mechanism of ignition.

The behaviour of heated copper particles is largely unknown, but copper being non reactive, it cannot sustain a self supporting combustion. On the basis of the present tests a generalisation may be made on temperatures of copper particles in the experiments. Since copper wires showed similar maximum currents during pre-arcing period and similar arc energies, it is reasonable to assume that copper particles reached or exceeded a temperature of 2300°K .

Transmission of hot metal particles through the arrester apertures

Some work has been carried out in the past on the transmission of hot aluminium and copper particles produced by fusing wires, through the flanged gaps of flameproof apparatus. These investigators,^{4, 5, 6} used very high A.C. prospective currents and they showed that the presence of an explosive mixture in a vessel fitted with flanged gaps had no effect on the probability of an explosion transmission, but there was some evidence that larger currents result in higher probability of explosion transmission.

The present work showed that higher arc energies may somewhat increase the probability of ignition through the arrester. Photographic evidence indicated that this was caused by greater numbers of particles moving at higher velocities. The thinner and thickest wires gave the highest probability of igniting the flammable mixture outside the vessel; the intermediate diameter caused ignition less readily. The reason for this is not clear. It might seem that wires showing the largest arc energy per unit weight of aluminium should be the most incendive. This, however, does not apply as 0.04 cm (26 S.W.G.) and 0.07 cm-diameter (22 S.W.G.) wires showed the largest energy concentration. The interaction of particles and flow may account for this discrepancy. Photographic evidence showed that gaseous explosion accompanying fusing of the aluminium wire may increase the probability of ignition by entrainment of incandescent particles in the moving stream of gases. The role of expanding gases in explosion transmission may, however, be unimportant with wires fused at large arc energies, where many particles are capable of penetrating the arrester by the momentum imparted by the arc discharge.

The shield used in the tests will only arrest the particles produced by wires fused in positions remote from the arrester or in the middle of the shield near the side remote from the arrester. Once, however, wires are fused in a position where gases move at higher velocities, position B (Fig. 3) being an example, then the presence of the shield can actually assist the transmission of incandescent particles throughout the arrester. Thus, in practical applications, the presence of a shield will improve the performance of the arrester with aluminium wires fused in some positions but will have deleterious effects on the performance of the arrester with any wires fused in the vicinity of the space between the shield and the arrester. Consideration of relative positions of the moving particles and the moving gas may further elucidate this behaviour. For the particles to be transmitted by entrainment, both moving gases and the particles must be in the same place at a certain time. The region where gases move at high velocities is confined to the immediate vicinity of the shield's edge. With wires fused some distance away from the shield particles may impact the walls of the vessel and be at rest before the flow is established. On the other hand, many small particles may never reach the region where the flow of gases is being maintained. With wires fused near the arrester, flow commences shortly after the wire is fused and particles are generated within this region, thus conditions for entrainment are more favourable.

Although copper particles which penetrate the arrester are non incendive they must be well above the ignition temperature of propane-air mixture before emerging from the arrester. For with similar arc energies, copper particles could reach the temperature of 2300°K which is the ignition temperature of aluminium. Furthermore, incandescent copper ignited eroded aluminium thus lending further support to this assumption. It appears that the copper particles lost heat at a very high rate to emerge from the arrester at the temperature lower than ignition temperature of propane-air mixture.

Effect of fuse wire on the maximum explosion pressure

Large ignition sources in vented explosions are known to increase the maximum explosion pressure by creating multiple flamefronts and by generating turbulence in the unburnt gas. Tests with ignition by the fused wires confirm this and although the results are not directly comparable as the inductive spark source was further away from the arrester than the fuse wire, they do show some increase.

Effect of transmission of explosion by fused aluminium wires on the practical application of the method

The tests showed that arresters offer protection against ignition through the arrester by copper particles produced by electrical discharges. They do not, however, offer protection against burning aluminium particles produced by similar discharges. Photographic evidence indicated that the hazard is greater when an explosive mixture is present within the vessel; under these conditions relatively small prospective currents would result in the ignition of the flammable mixture on the outside of the vessel. Protection of arresters by simple shields is not considered to be practicable. The obvious solution of trying to arrest such particles by arresters with labyrinth type of apertures was not attempted as such arresters could not have been produced economically. Enclosing the aluminium wires within strong sleeving eliminated this danger as all the particles were contained within the sleeving. Another solution for ensuring safety is exclusion of aluminium and aluminium alloys wires in construction of such equipment. Aluminium or its alloys used as a material for bodies or components of containers presents a similar hazard; these metals when situated near the arrester may be eroded and ignited by hot copper particles. Present evidence indicates that this hazard occurs only when aluminium or its alloys are placed in close proximity of the arrester. It follows that a container made from aluminium could be made safe by lining the area within a few centimetres of the arrester periphery with metal other than aluminium.

Conclusions

1. Particles of copper produced by fusing copper wires with currents of 300 to 1200 A at 240 V. DC did not ignite the propane-air mixture after penetrating the apertures of crimped ribbon arresters.
2. Particles of aluminium produced by fusing aluminium wires with the same currents did ignite the propane-air mixture after passing through the arrester.
3. If fusing of the aluminium wire was accompanied by gaseous explosion this facilitated the transmission of incendiary particles produced by wires fused by low energies, and of particles produced by wires situated at remote positions from the arrester.
4. If particles of copper impacted aluminium alloy before entering the arrester they eroded and ignited portions of this alloy, and these portions may penetrate the arrester and ignite the propane-air mixture outside the test vessel.
5. Incendiary particles of aluminium could bypass obstacles placed in their trajectory.
6. Particles of aluminium produced by fusing a wire within an insulating sleeving were contained within such sleeving providing its ends were sealed and the sleeving material was strong enough not to be disrupted by the arc.

References

1. PALMER, K. N. and ROGOWSKI, Z. W. Joint Fire Research Organization F.R. Note 613.
2. PALMER, K. N. and ROGOWSKI, Z. W. Joint Fire Research Organization F.R. Note 658.
3. CHRISTENDEN, H. C., KNIPE, R. H. and GORDON, ALVIS, S. Pyrodynamics 1965 3 91-119.
4. MASKOW, H. The Eighth International Conference of Directors of Safety in Mines Research 1954. S.M.R.E. Paper No.28.
5. HULSBURG, F. The Seventh International Conference of Directors of Safety in Mines Research 1952. S.M.R.E. Paper No.28.
6. EINSELLE, A. S.M.R.E. Translation. No.3679.

Acknowledgment

Mr. M. R. Richardson and Mr. A. R. Pitt assisted in experimental work.

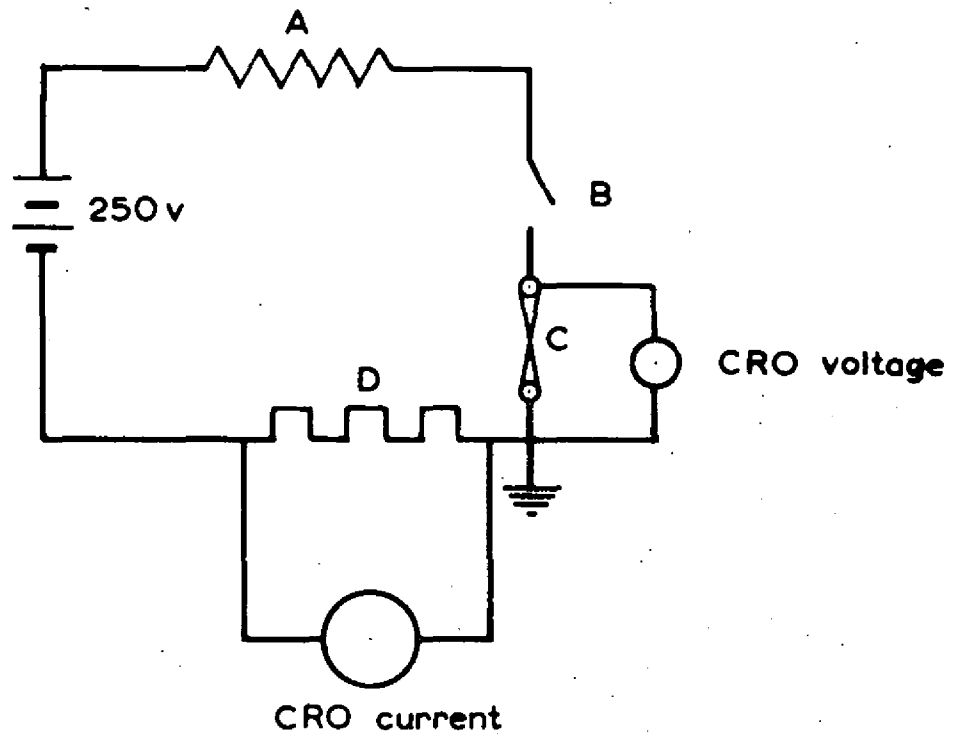

- A. Variable resistance
- B. Contactor
- C. Fuse wire
- D. Shunt

FIG.1. DIAGRAM OF THE CIRCUIT USED FOR FUSING THE WIRES

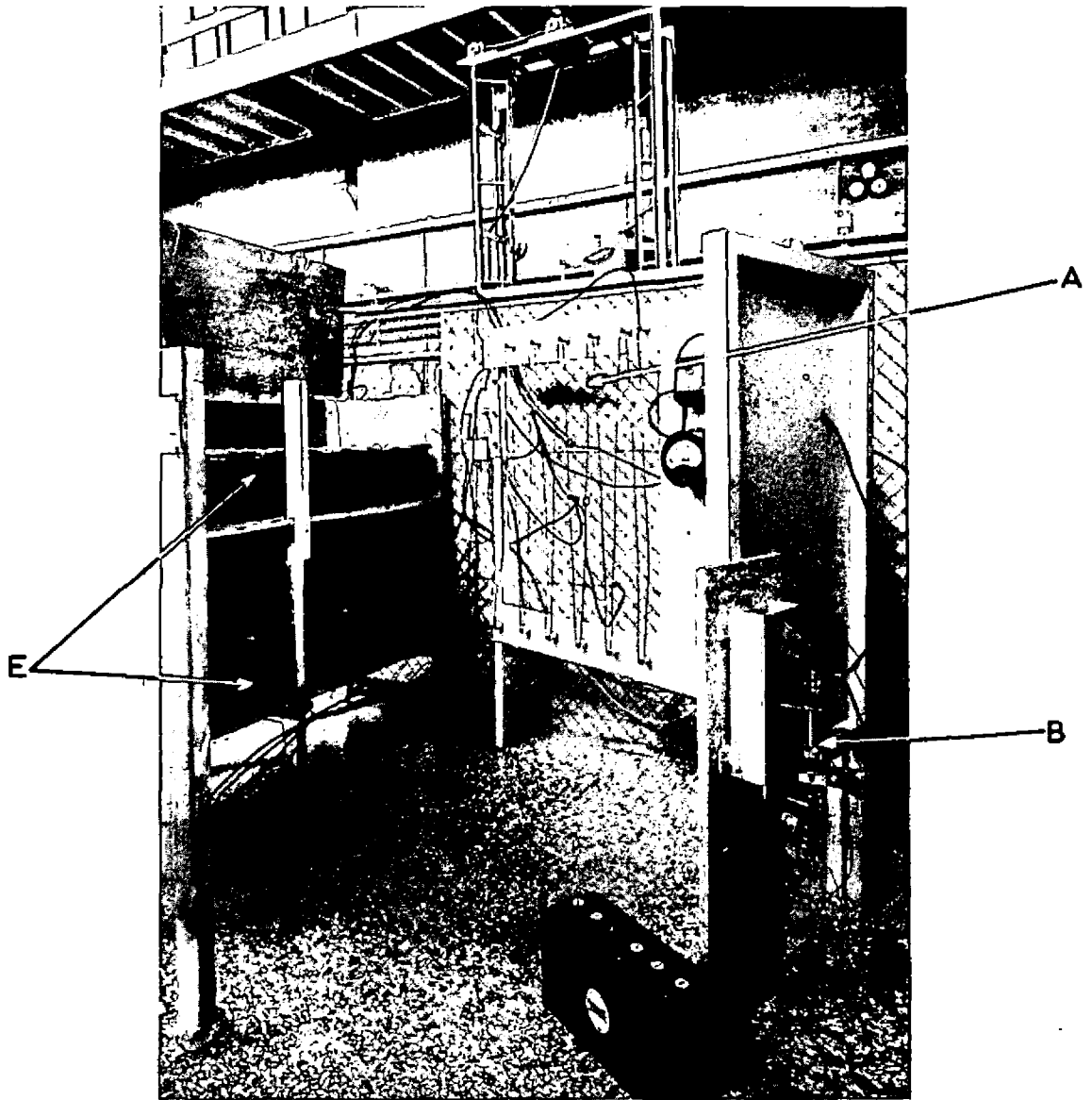

- A VARIABLE RESISTANCE
- B CONTACTOR
- E ACCUMULATORS

FIG.2. POWER SUPPLY AND CONTROL GEAR

This shield not present unless indicated in text

Arrester

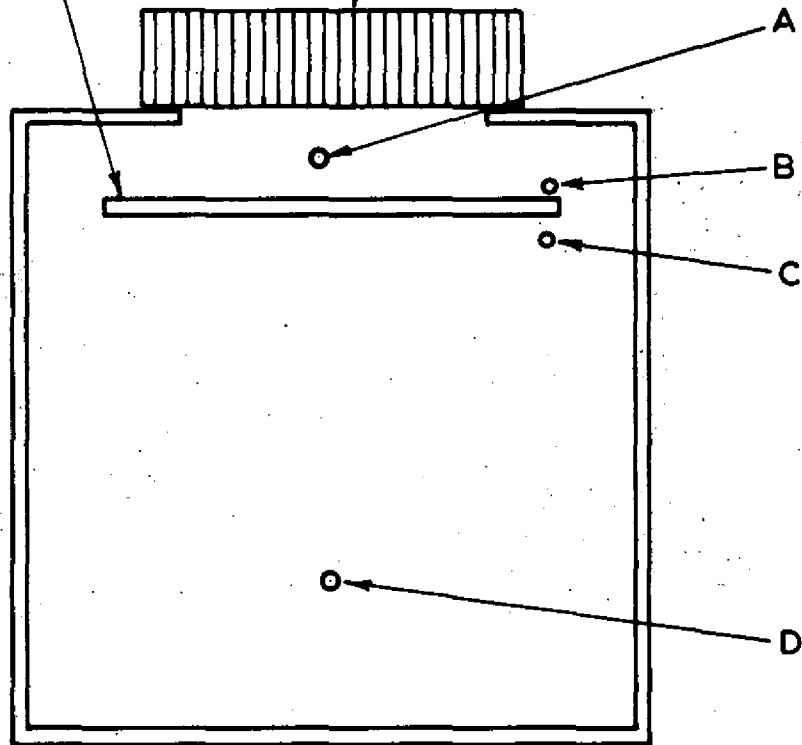

Not to scale

FIG. 3. SHOWING VARIOUS POSITIONS OF FUSED WIRES

118069 FR676

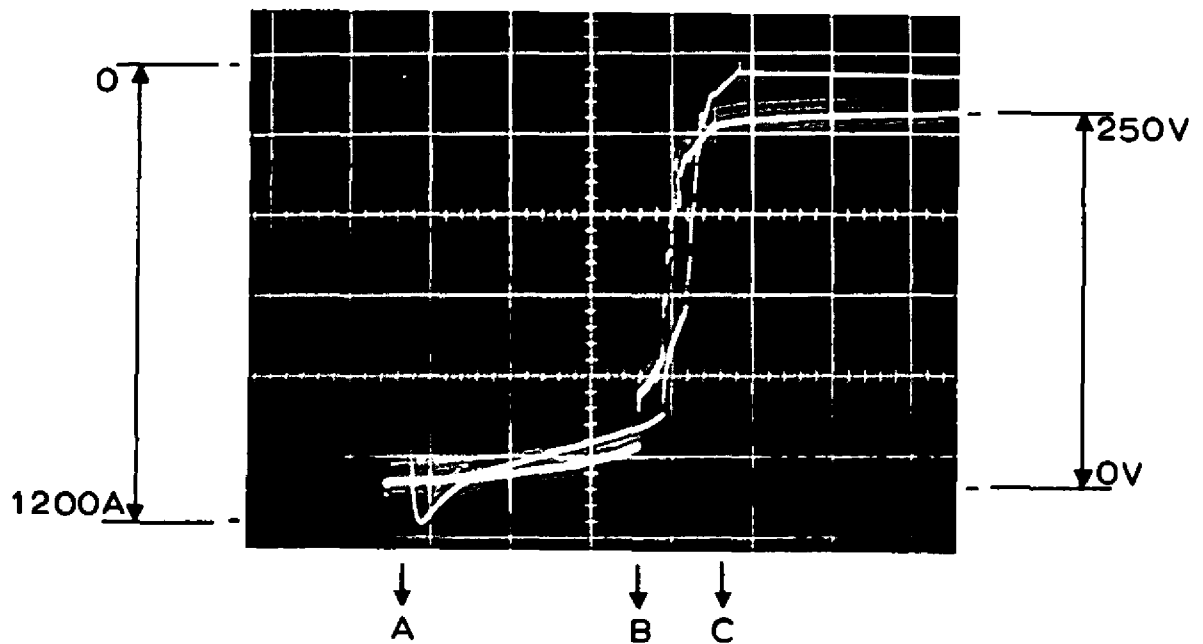

FIG.4. OSCILLOSCOPE RECORD OF VOLTAGE AND CURRENT WHILE FUSING 0.07cm DIAMETER (22 S.W.G.) COPPER WIRE AT A PROSPECTIVE CURRENT OF 1200 A

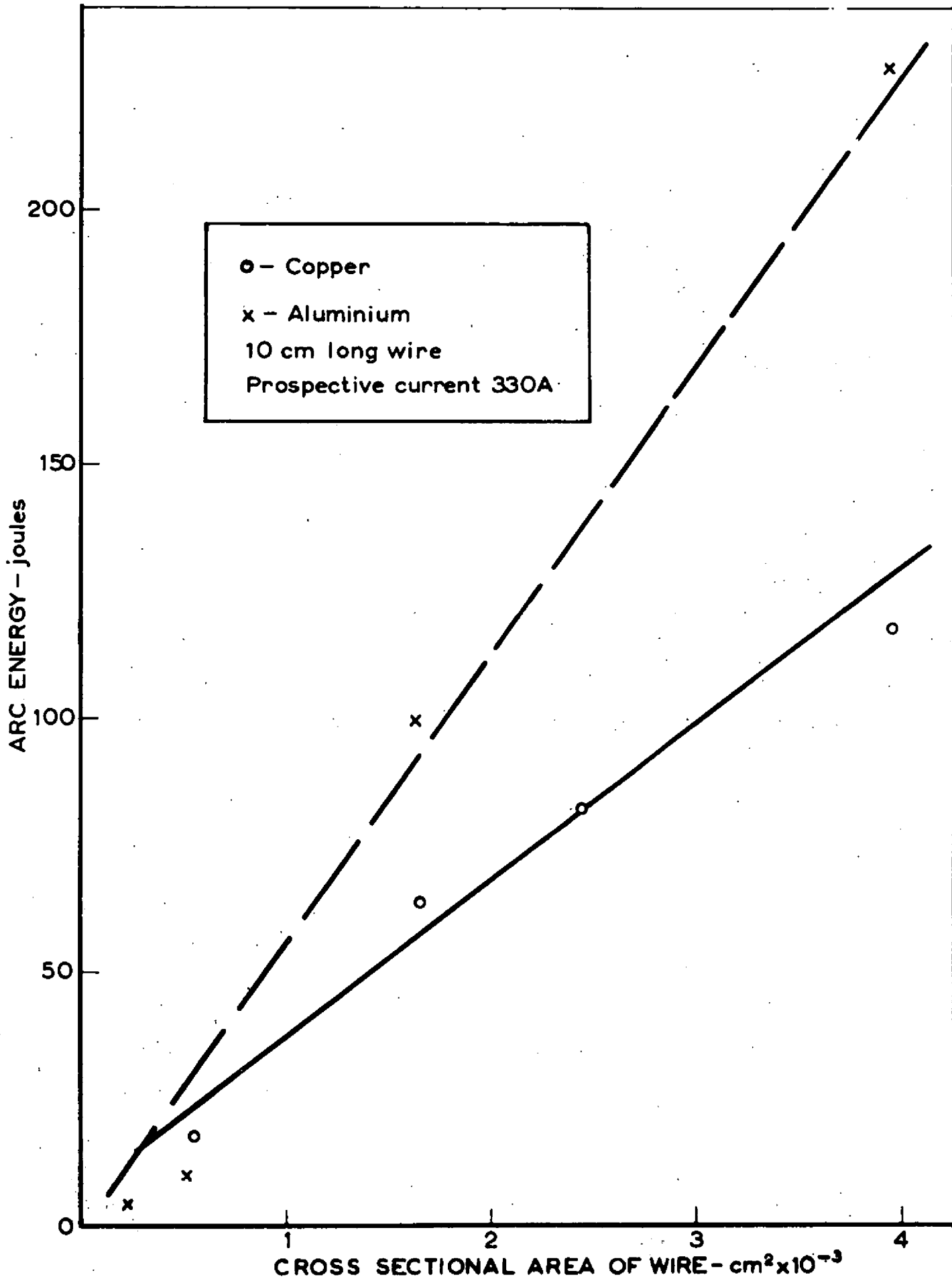

FIG. 5. RELATION BETWEEN THE THICKNESS OF WIRE AND ARC ENERGY

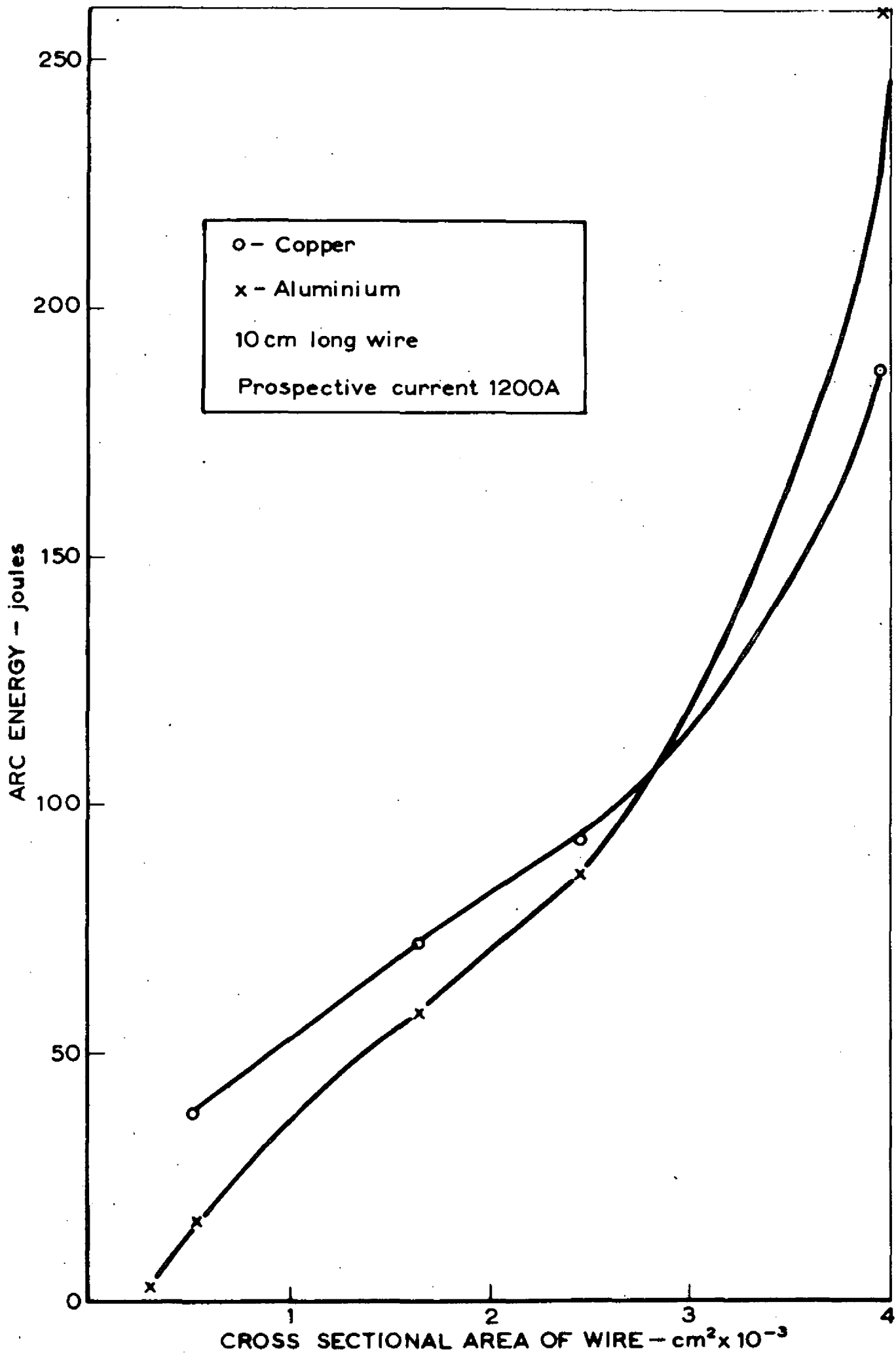
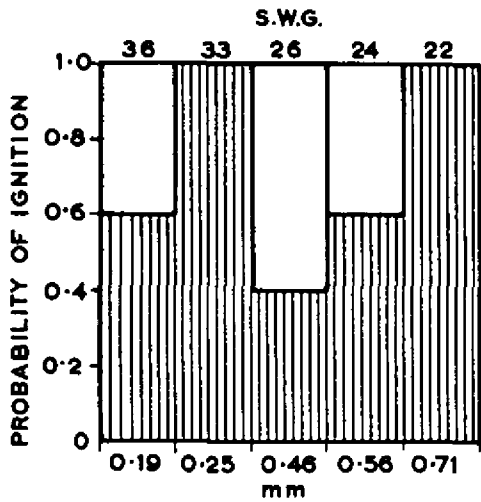

FIG. 6. RELATION BETWEEN THE THICKNESS OF WIRE AND ARC ENERGY

FR 676 / 80 x 1



Wire position A
Prospective current
330A

A

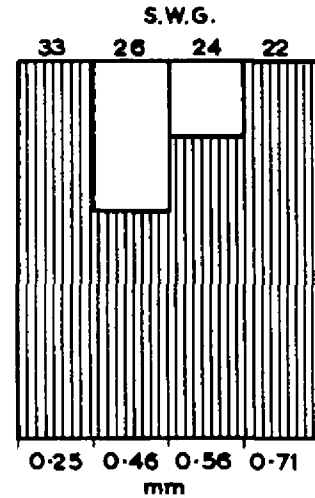

Wire position A
Prospective current
650A

B

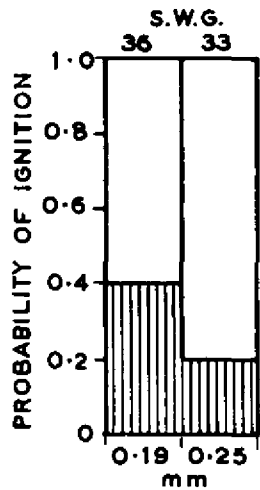

Wire position D
Prospective current
330A

C

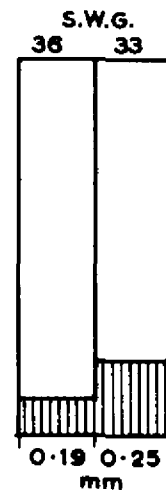

Wire position D
Prospective current
1200A

D



Ignition



No ignition

Arrester a, 11 cm diameter
All histograms based on ten tests

FIG. 7. PROBABILITY OF IGNITION BY FUSED ALUMINIUM WIRES IN VARIOUS POSITIONS IN RELATION TO THE ARRESTER

118072 FR076

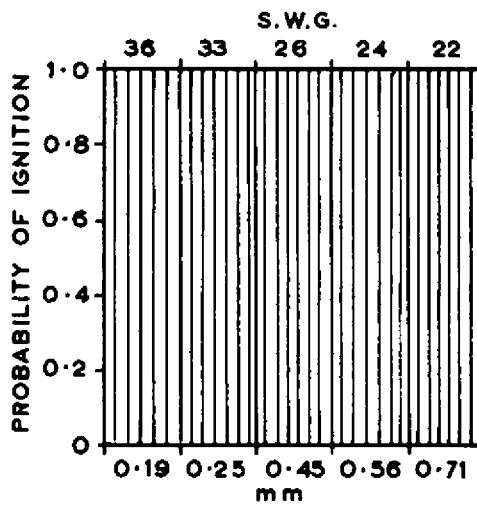

 Ignition

Arrester b, 11 cm diameter
 Prospective current 330A
 Histogram based on three tests

FIG. 8. PROBABILITY OF IGNITION BY FUSED ALUMINIUM WIRE IN POSITION A

110073 FR676

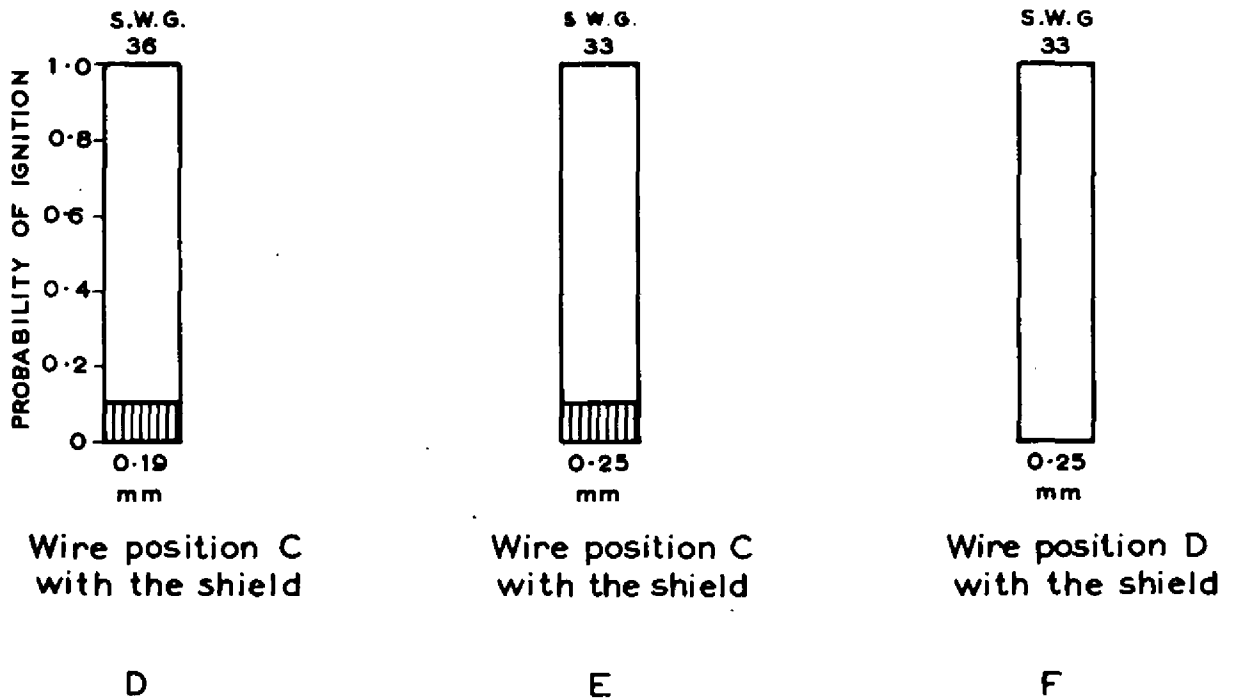
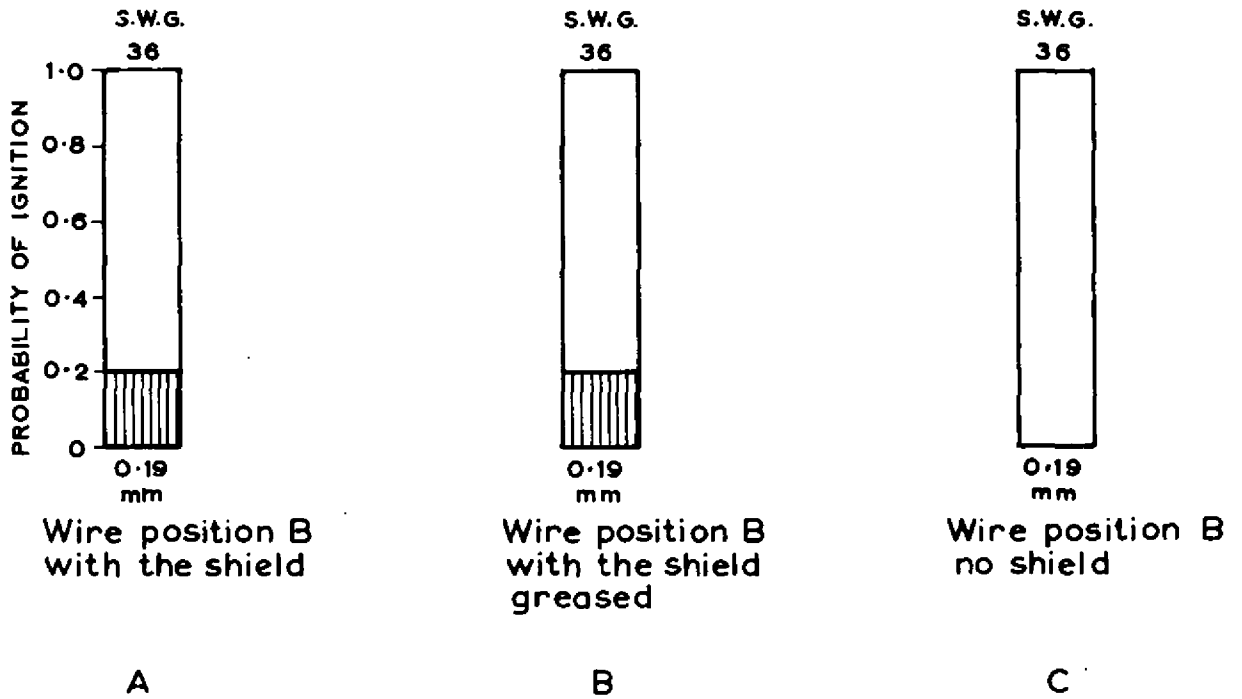

 Ignition
  No ignition

Arrestor a, 11 cm diameter
 Prospective current 330A
 All histograms based on ten tests

FIG. 9. PROBABILITY OF IGNITION BY FUSED ALLUMINIUM WIRES IN VARIOUS POSITIONS IN RELATION TO THE ARRESTER-WITH AND WITHOUT SHIELD

1/6074 FR. 676

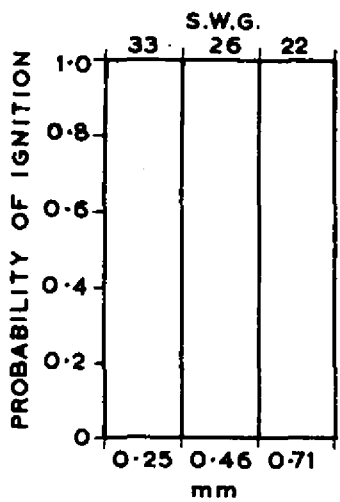

Prospective current
650A

A



Prospective current
1200A

B

Arrester a, 11 cm diameter
Histograms based on ten tests

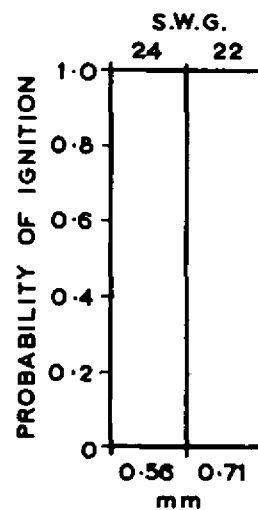
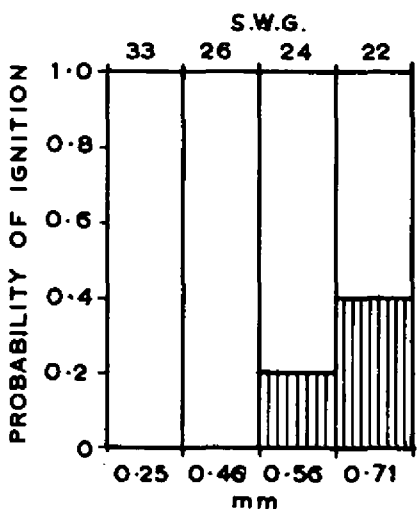

Aluminium cover around
arrester lined with nickel foil

C

D

Arrester b, 2.7 cm diameter
Prospective current 1200A
Histograms based on ten tests



Ignition



No Ignition

FIG. 10. PROBABILITY OF IGNITION BY FUSED COPPER WIRE IN POSITION A

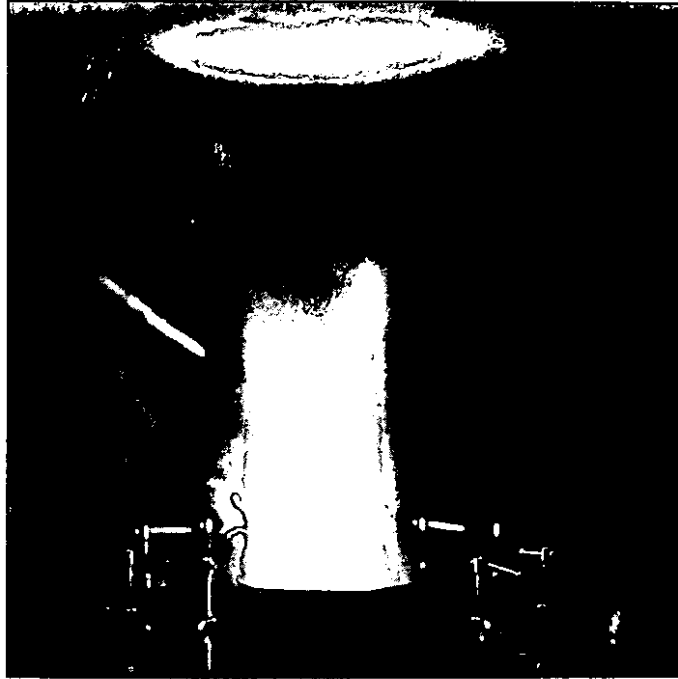

(A) TEST VESSEL CONTAINING AIR



(B) TEST VESSEL CONTAINING 4 per cent PROPANE-AIR MIXTURE

ARRESTER a 11cm DIAMETER, WIRE 0.07cm DIAMETER (22 S.W.G.), PROSPECTIVE CURRENT 330A. WIRE POSITION A

FIG.11. STILL PHOTOGRAPHS OF ALUMINIUM PARTICLES EMERGING FROM THE ARRESTER

Incendive
Particles

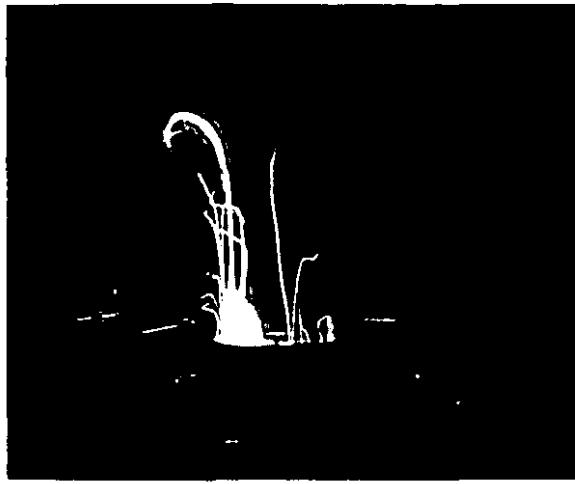

(A) TEST VESSEL CONTAINING AIR

Incendive
Particles



(B) TEST VESSEL CONTAINING 4per cent PROPANE-AIR

Non
Incendive
Particles

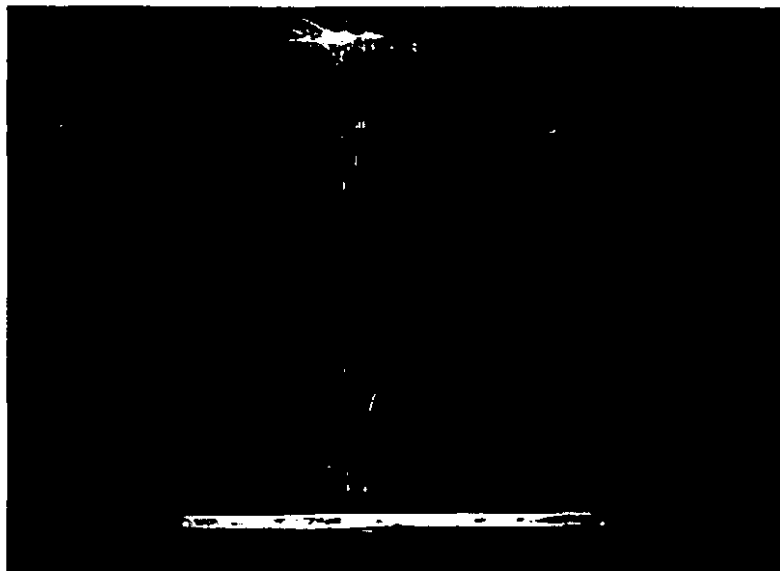

(C) TEST VESSEL CONTAINING 4per cent PROPANE -AIR
SHIELD IN POSITION

ARRESTER ϕ 11cm DIAMETER, WIRE 0.07cm DIAMETER (22 S.W.G.),
PROSPECTIVE CURRENT 1200A. WIRE POSITION A

FIG.12. STILL PHOTOGRAPHS OF ALUMINIUM PARTICLES EMERGING
FROM THE ARRESTER

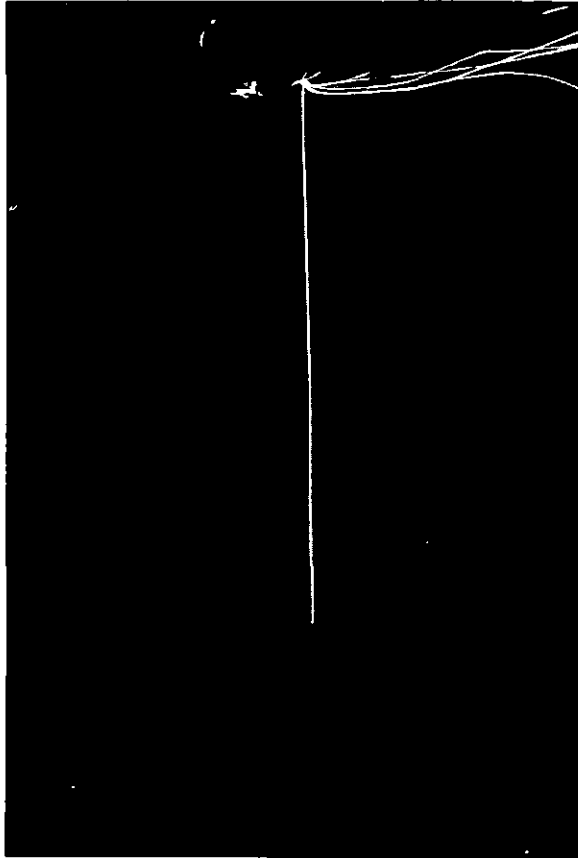

ARRESTER a 11cm DIAMETER, WIRE 0.019cm DIAMETER (36 SWG). WIRE POSITION
D. TEST VESSEL CONTAINING 4 per cent PROPANE-AIR

FIG.13. PHOTOGRAPH OF PARTICLES OF ALUMINIUM WIRE
EMERGING FROM THE ARRESTER

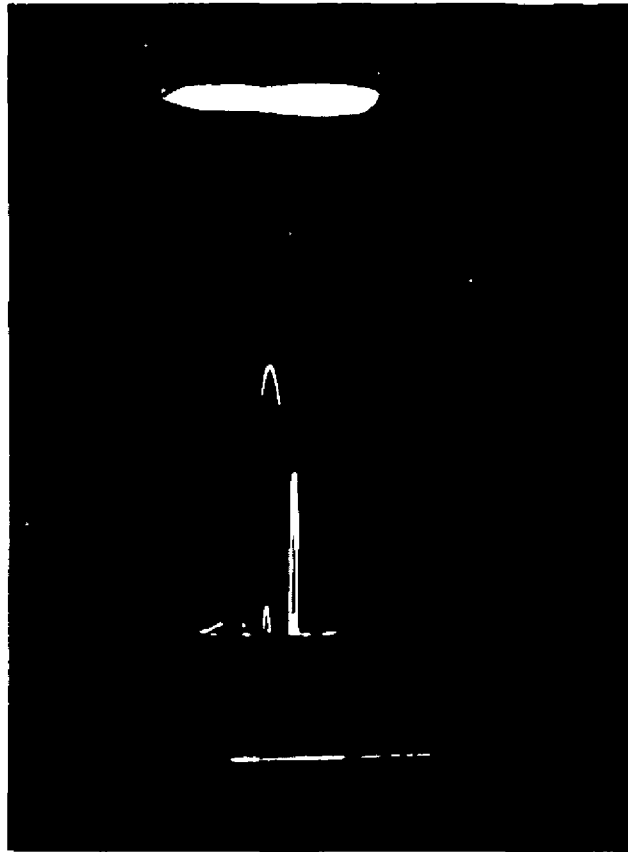
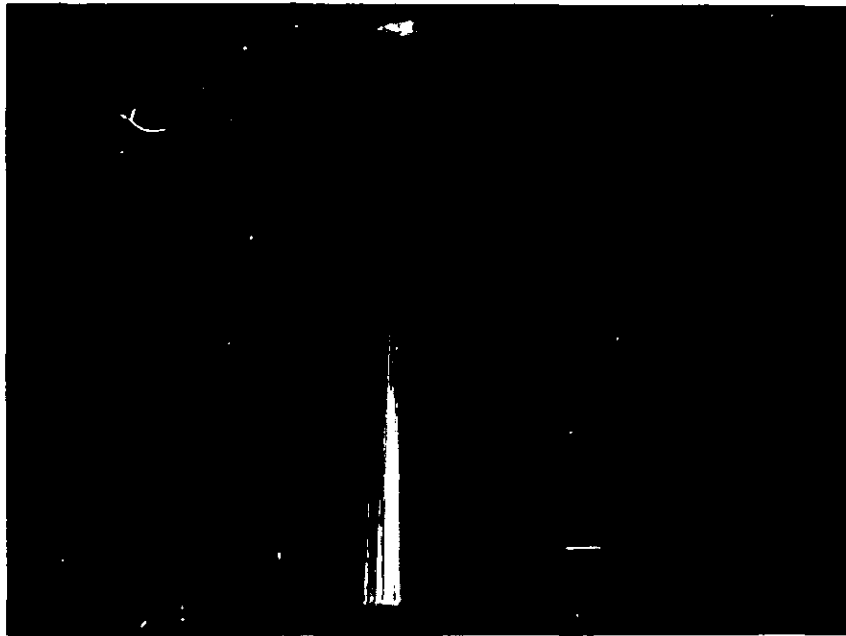
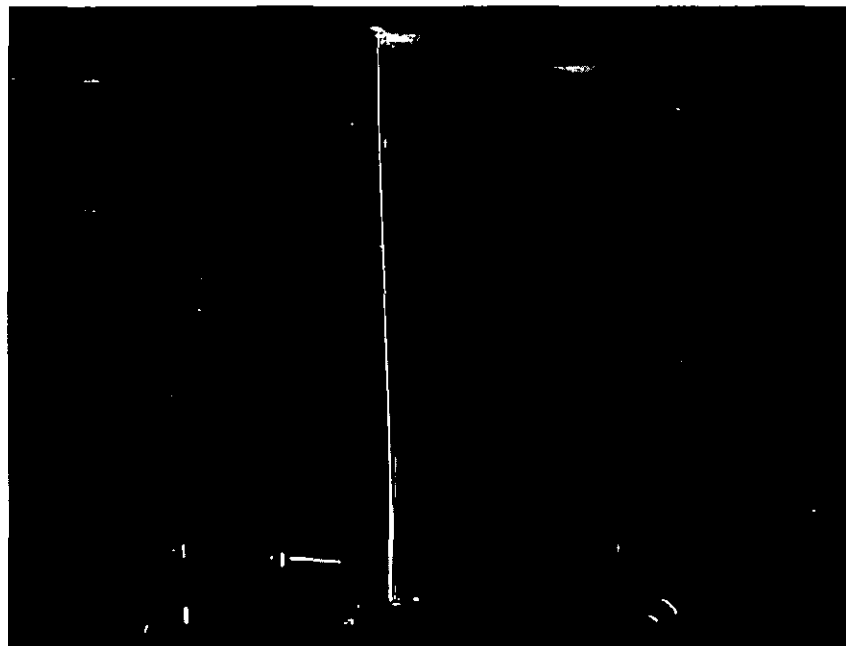

FIG.14 PHOTOGRAPH OF PARTICLES OF COPPER WIRE EMERGING FROM THE ARRESTER—TYPE α 11cm DIAMETER, WIRE 0.071cm DIAMETER (22 S.W.G.), PROSPECTIVE CURRENT 1200 A. WIRE POSITION A



(A) ALUMINIUM ALLOY COVER LINED WITH NICKEL FOIL



(B) ALUMINIUM COVER UNLINED

ARRESTER B 2.7 cm (1.15 in) DIAMETER, WIRE 0.07 cm DIAMETER (22 SWG.),
PROSPECTIVE CURRENT 1200 A. WIRE POSITION A

FIG.15. STILL PHOTOGRAPHS OF PARTICLES OF COPPER
EMERGING FROM THE ARRESTER

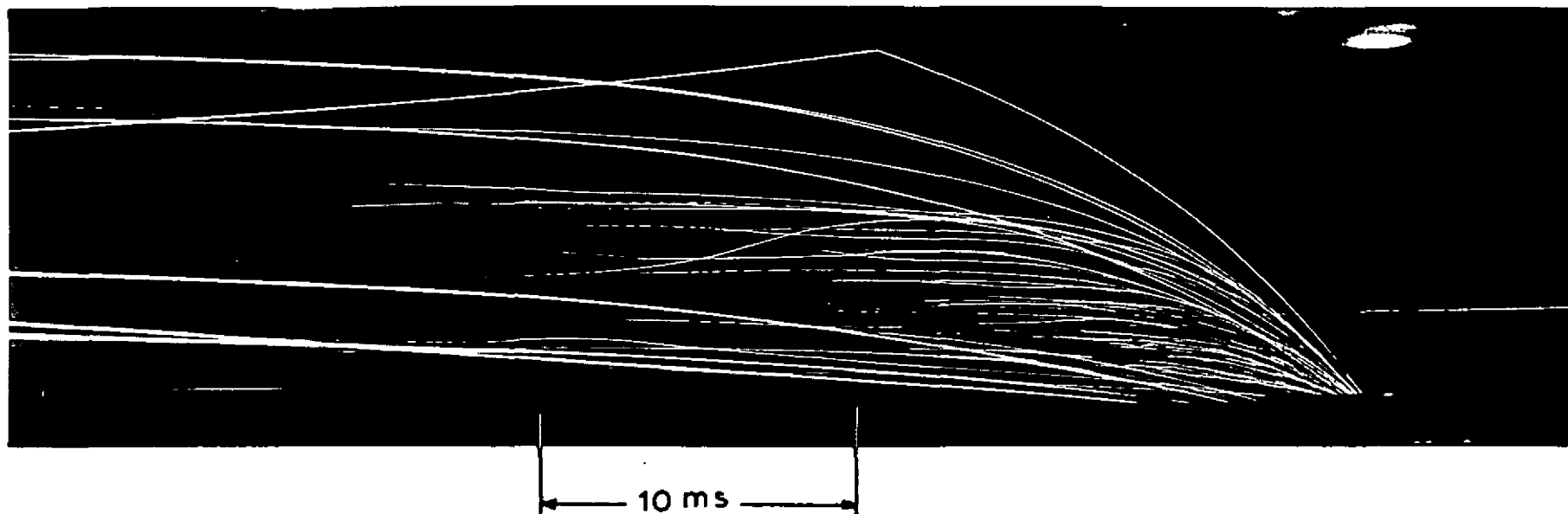

FIG.16. DRUM CAMERA RECORD OF PARTICLES PRODUCED BY FUSING ALUMINIUM WIRE
0.07cm DIAMETER (22 S.W.G.), ARRESTER α , PROSPECTIVE CURRENT 1200A IN AIR. WIRE
POSITION A

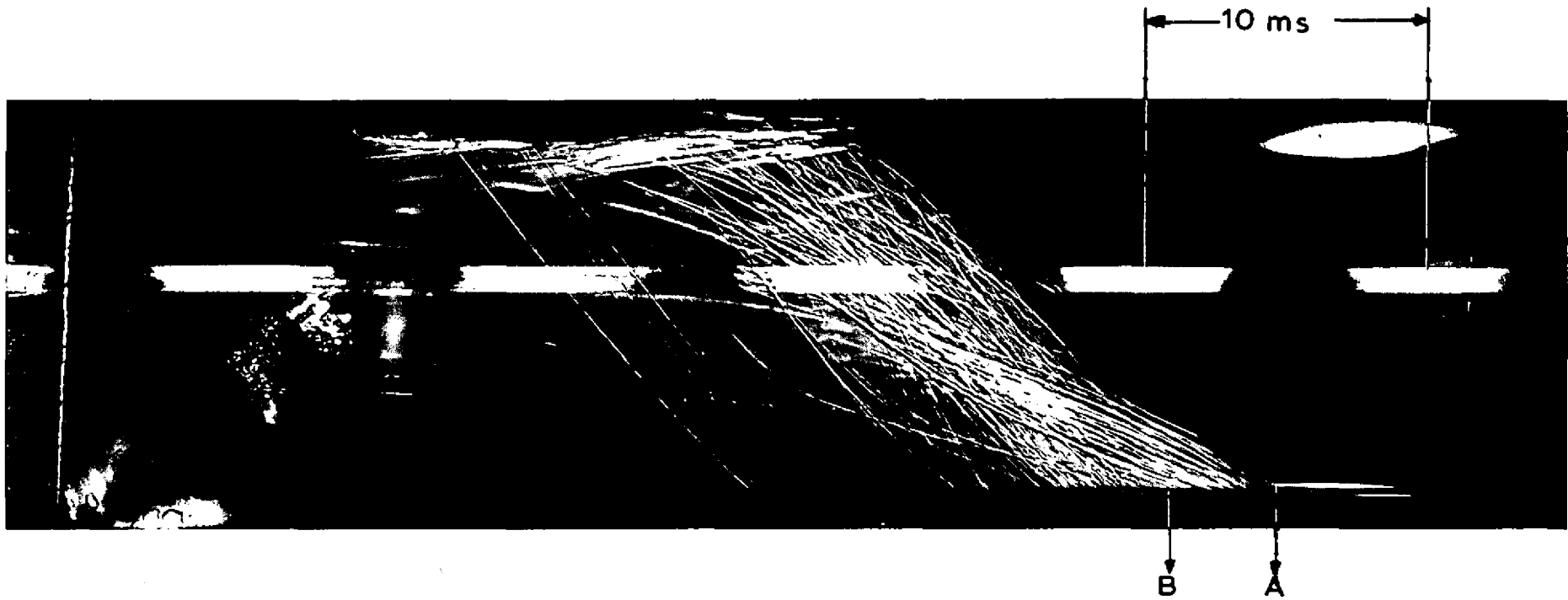

FIG.17. DRUM CAMERA RECORD OF PARTICLES PRODUCED BY FUSING ALUMINIUM WIRE 0.07cm DIAMETER (22 SW.G.), ARRESTER α , PROSPECTIVE CURRENT 1200A IN 4 per cent PROPANE-AIR MIXTURE, WIRE POSITION A

11

12