



LIBRARY REFERENCE ONLY

THE LIBRARY FIRE RESEARCH STATION BOREHAM WOOD HANTS.	6 1 72
No A99FR . N 892	

Fire Research Note No 892

**INTUMESCENT COATED HONEYCOMBS AS FIRE
RESISTANT MATERIALS**

by

D. I. LAWSON and E. G. BUTCHER

October 1971

**FIRE
RESEARCH
STATION**

F.R.Note No. 892
October 1971

INTUMESCENT COATED HONEYCOMBS AS FIRE
RESISTANT MATERIALS

by

D. I. Lawson and E. G. Butcher

SUMMARY

The use of an intumescent coated paper honeycomb as a fire resistant barrier for application to fire dampers, lightweight partitions and doors is described.

The results of tests are given and design criteria established for the three applications.

KEY WORDS: Fire, damper, honeycomb, intumescent, coating, fire-resistance test, partition, doors.

Crown copyright

This report has not been published and should be considered as confidential advance information. No reference should be made to it in any publication without the written consent of the Director of Fire Research.

INTUMESCENT COATED HONEYCOMBS AS FIRE
RESISTANT MATERIALS

by

D. I. Lawson and E. G. Butcher

INTRODUCTION

Intumescent paint under normal conditions is a relatively thin coating which has the same protective function as any other paint. On being heated by fire, it will, by reason of a foaming agent included in its formulation expand to form a thick insulating coating which will protect the material to which it is applied.

The thicker the final foamed layer the longer the period of fire protection which will be obtained. When the surface to be protected is horizontal more than one coat of paint is an advantage but when the surface is vertical the thickness of the paint must be limited since in its early stages the intumescent layer is fluid and excessive thickness will fall away from the surface it is designed to protect.

The use of a honeycomb^{1,2,3} matrix to carry the intumescent paint overcomes this difficulty and provides a protective layer to which there is no thickness limitation.

Practical applications

The principle of the honeycomb matrix used to support a thick layer of intumescent paint has several possible applications⁴, for instance, to lightweight fire resisting partitions or door constructions, to a fire damper construction for ventilation ducting, to suspended ceilings or to preformed protective casings for structural steelwork.

Experiments have now been carried out on the first two of the above applications and design data are available.

Lightweight Partitions

Lightweight partitions and doors constructed by cementing a facing material such as hardboard or thin plywood onto each side of a paper honeycomb core are already in fairly common use but when constructed in this relatively simple way they will have very little, if any, resistance to fire.

However if the internal core material, usually a paper honeycomb, is coated with intumescent paint before the facing sheets are cemented into place the partition structure will, according to the tests on small specimens described below achieve a fire resistance which will depend only on the dimensions and paint application to the core.

The dimensions of the honeycomb cell and the weight of intumescent paint application to the cell walls are of course related since the primary requirement is that the intumesced paint should completely fill the honeycomb cell and obviously the larger the honeycomb cell the heavier the application of paint needs to be. On this basis however, the total paint weight per unit area of partition will be the same and independent of cell size and depend only on honeycomb thickness and increasing the honeycomb thickness will increase the fire resistance of the partition.

In the constructions used in the test described below a honeycomb cell size of 25 mm was used in all the specimens. Hardboard 4 mm thick was used as the facing panel and an intumescent paint itself was used as the adhesive to cement the facing panels to the honeycomb core. Hence the internal faces of these were coated with intumescent paint as well as the surfaces of the honeycomb core. Four thicknesses of honeycomb were used, 13 mm, 25 mm, 38 mm and 51 mm, and in addition the thickness of paint application was also varied.

The intumescent paint used was one of those commercially available.

Tests have been carried out in a gas fired furnace in which the B.S. 476 standard time-temperature curve for fire resistance tests can be followed.

The maximum sized specimen used was 1 m x 1 m but for most of the tests smaller specimens of 0.23 m x 0.23 m were used.

The British Standard Fire Resistance test, B.S. 476 : Part 8 requires that the element of structure being tested (a) shall not collapse, (b) shall not develop cracks, fissures or other orifices through which flames can pass and (c) the average temperature on the unexposed face shall not increase by more than 139 degrees centigrade above the initial temperature nor shall the temperature at any point of the unexposed face increase by more than 180 degrees centigrade nor reach a value of 221°C whichever is the lesser value.

For the case of partitions the above three criteria are applied in assessing the test results but in the case of doors the last requirement, that for insulation is not required.

The results of the tests carried out are shown in Figures 1 and 2. Figure 1 relates to partitions in which the insulation requirement would apply and Figure 2 relates to doors. In both the weight of paint application per unit area of

partition or door is related to the Fire Resistance. It should be noted however that these results relate to tests on small specimens and need to be confirmed for large elements before the results can be taken as applying to a standard Fire Resistance Test for a full size component.

The design lines given in Figures 1 and 2 can also be stated as follows:-
For Partitions

$$T = (12W + 9) = 3(4W + 3)$$

For Doors

$$T = (16W + 12) = 4(4W + 3)$$

where

T is the Fire Resistance in minutes

and

W is the paint weight in kg per sq metre

The general arrangements used in the tests described are shown in Plate 1 in which four small specimens are in position in the furnace awaiting the start of the test.

In plate 2 the same sections are shown at the end of the test, the photograph being taken from the furnace side of the specimen.

In plate 3 a larger specimen is shown, a door section 0.9 m square; (a) is the section before test and (b) and (c) are after test from the furnace side and unexposed side respectively.

Fire dampers in ventilation ducts

The intumescent coated honeycomb has also an application as a fire damper in a ventilation duct, and in this it has the merit that it is cheap, has no moving parts, can be resistant to corrosive vapours and can easily be replaced.

The construction used for this application, which is shown in Fig.3, allows a section of coated honeycomb to be easily slipped into position in a ventilation duct.

In the normal, 'no-fire' state the honeycomb will present a very small obstruction in the duct thus allowing the ventilating air to flow unimpeded but immediately a fire occurs and the hot gases flow into the ventilating duct the intumescent paint will swell and fill the cores of the honeycomb and form a complete seal across the duct, so preventing the fire from spreading about the building by means of the ducting.

In its normal state, with a honeycomb cell size of 9 mm and an assumed paint thickness of 0.2 mm the honeycomb structure will occupy only $\frac{1}{10}$ of the total duct area and with a larger cell size the blanked off area will be correspondingly less.

Tests have been carried out on a series of damper assemblies using the construction shown in Fig.3 and the testing furnace already described. Plate 4 shows the honeycomb section being slipped into its holder immediately prior to test and Plates 5 and 6 show the two honeycomb dampers before and after a 1 hour test viewed from the furnace side of the ducting. Plate 7 shows the same dampers seen from the unexposed side at the end of the same test, i.e. after 1 hour exposure in a furnace following the standard time/temperature curve.

The results of this series of tests is shown in the graph of Figure 4. In all of the tests shown here the honeycomb cell size was 9 mm, the honeycomb thickness was 38 mm and the relation between the weight of paint application and the period of fire resistance obtained is shown. Two types of commercially available paint were used.

The relation shown in the graph can also be expressed as:-

$$T = 12.5 W$$

where T is the fire resistance

and W is the weight of paint application in kg per square metre of damper area.

Tests were also carried out in the same furnace and with the same mounting arrangement but with an air extract suction applied to the damper.

In these tests the honeycomb damper successfully sealed the duct against a negative pressure of 2.5 mm water gauge and the application of this pressure did not affect the fire performance in any way.

In later tests the honeycomb damper was subject to a real fire situation. Three outlet grilles, each 0.23 m square were placed at a height of 1.5 m along one wall of a small fire chamber (5 m x 3.5 m x 3 m high).

One grille was left completely open, another had a honeycomb damper placed at its opening and the third had a honeycomb damper and an air extract system coupled to it. The paint weights used on the honeycombs in this test was that which would give 45 minutes fire resistance.

A fire was initiated in the room using 65 kg of wood fuel arranged in the form of a crib 1.8 m long, 0.6 m wide and 0.6 m high and placed at the end of the room adjacent to the ventilation grilles.

The fire developed quickly because of the small stick size used in the crib and both of the grilles fitted with the honeycomb dampers were completely sealed 1 minute after starting the fire and no smoke or flames were passed by them for the whole of the duration of the fire, which was approximately 20 minutes. In contrast a very considerable quantity of smoke and some flame emerged from the grille which had no damper fitted for the whole of the fire duration.

Conclusions

- (1) Paper Honeycomb structures coated with intumescent paint can achieve a Fire Resistance of up to one hour in the three applications described.
- (2) The required Fire Resistance (T) can be related to the weight of paint application (W) as follows:
 - (a) For partitions $T = 12W + 9$
 - (b) For doors $T = 16W + 12$
 - (c) For dampers $T = 12.5 W$

where T is expressed in minutes and W in kg/m^2

The use of these formulae should not however be applied outside the range of the experimental points shown on Figs 1, 2 and 4.

- (3) The saving in overall weight for this type of construction over that for traditional partitioning is very considerable and is illustrated in Fig.5, which shows that a partition constructed of the intumescent coated honeycomb will be only $\frac{1}{3}$ of the weight of a traditional construction giving the same fire resistance.

ACKNOWLEDGMENT

In all of this work the authors are indebted to Mr C Shore who has been responsible for all of the constructions and for the carrying out of the tests described.

REFERENCES

- (1) LAWSON, D.I. Intumescent Matrices as Fire Resistant Partitions
Fire Research Note No. 859 1971.
- (2) LAWSON, D.I. U.K. Patent Application 43423/71. Materials with intumescent surfaces.
- (3) LAWSON, D.I. U.K. Patent Application. The fabrication of intumescent surfaces.
- (4) LAWSON, D.I. U.K. Patent Application. The use of intumescent matrices as insulating coatings.

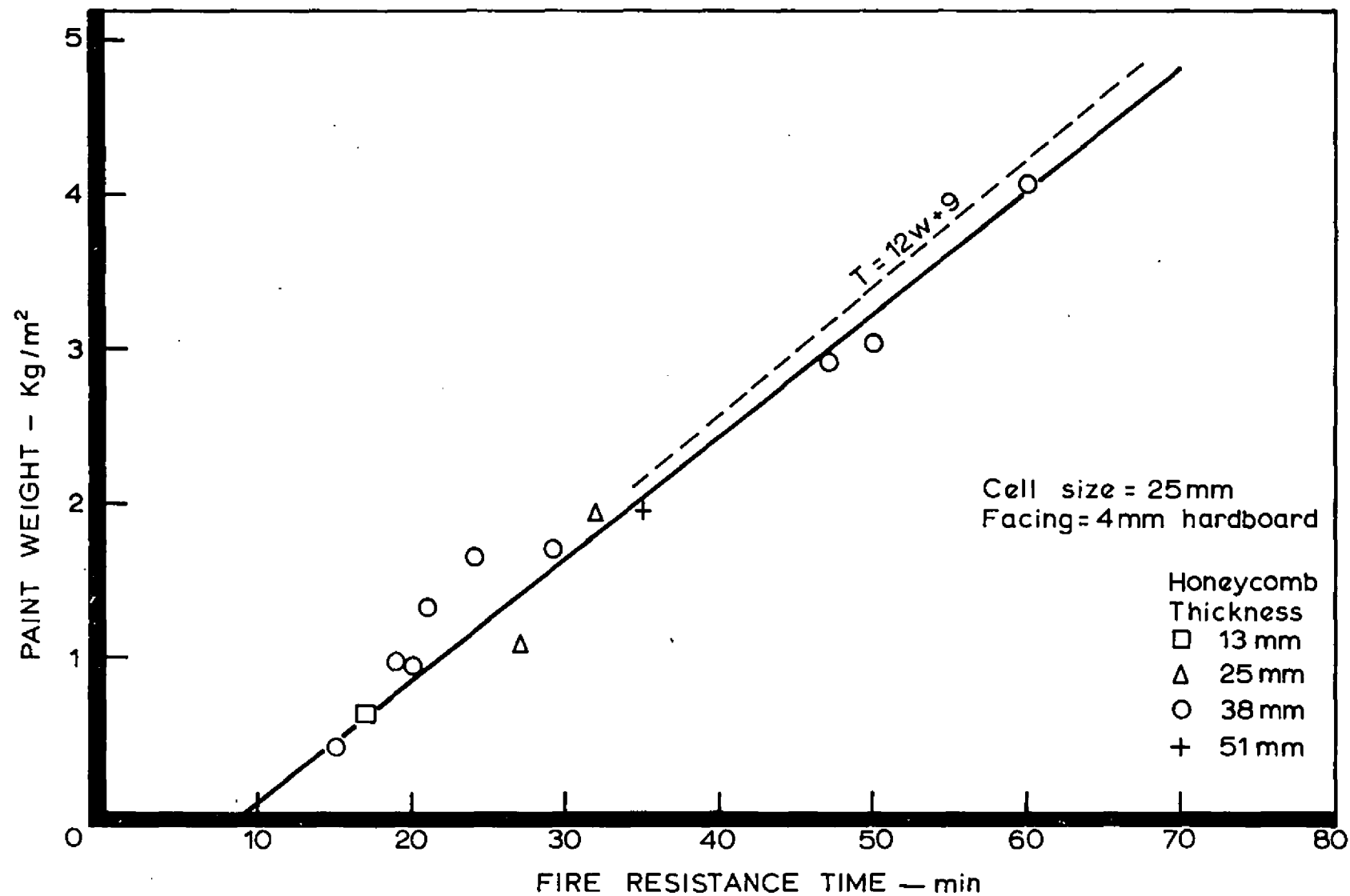

FIG. 1. FIRE RESISTANCE OF PARTITIONS (RESULTS FOR SMALL SPECIMENS, NOT FULL SIZE ELEMENTS AS REQUIRED FOR BS 476)

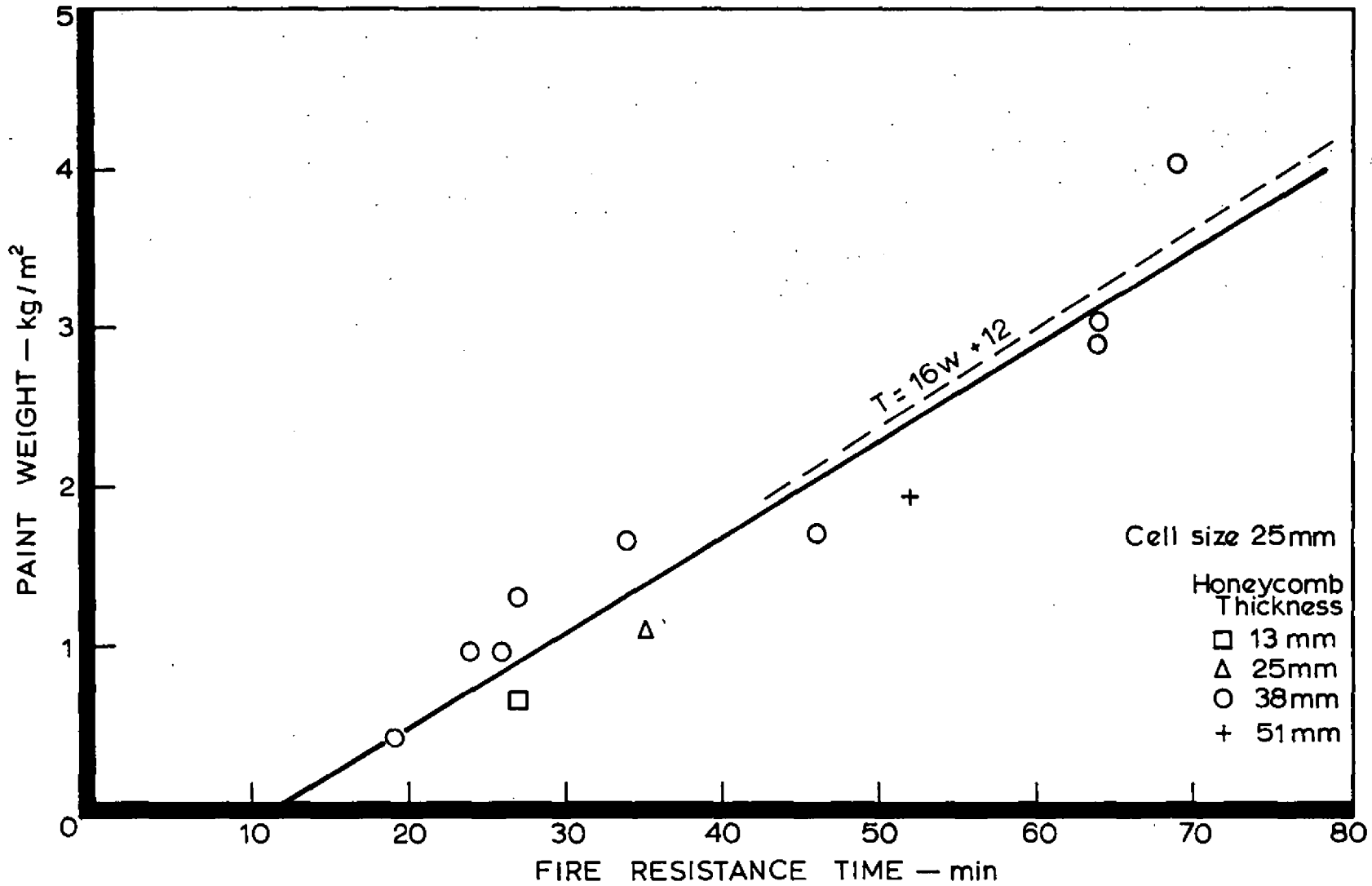
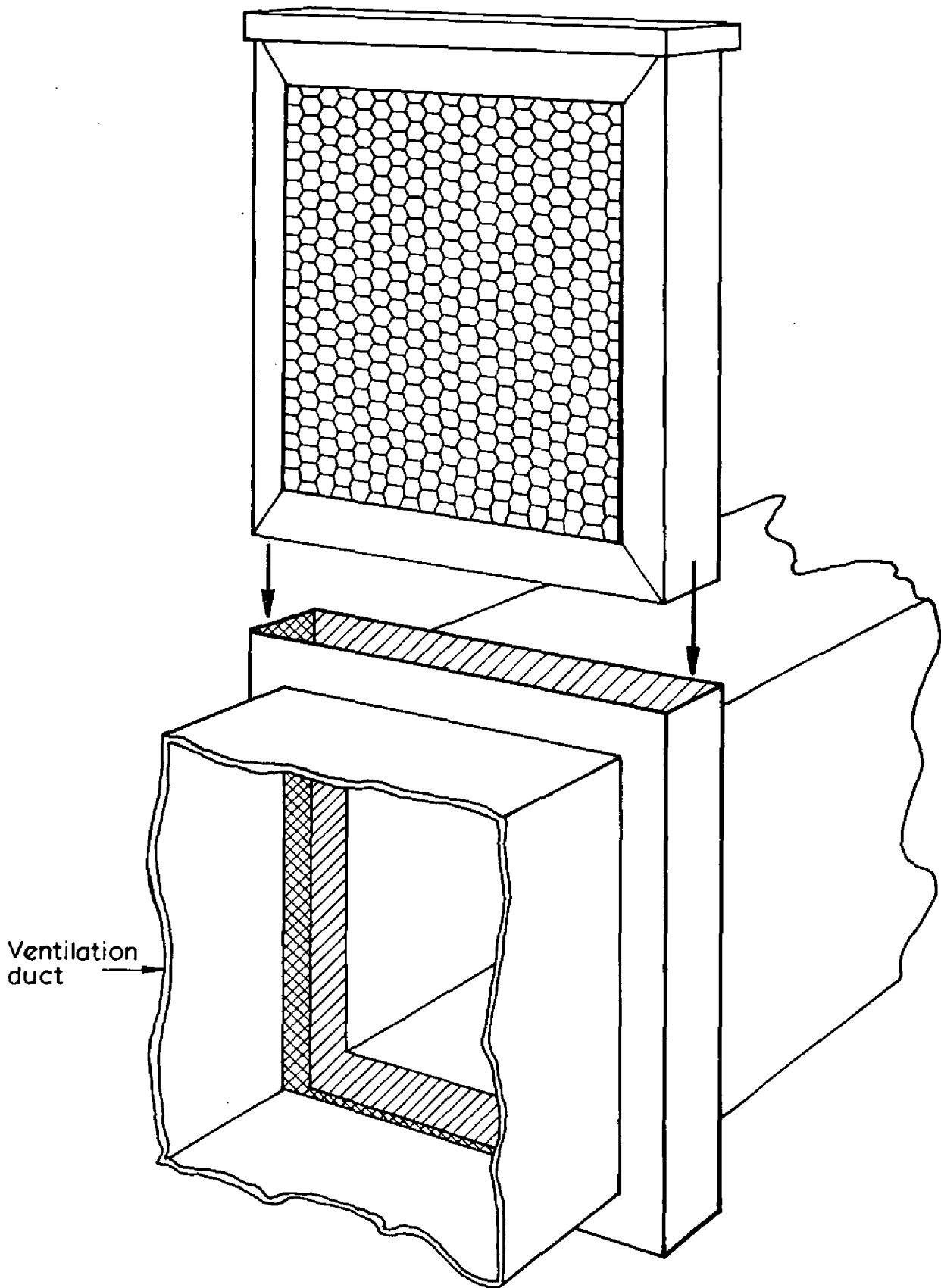

FIG. 2. FIRE RESISTANCE OF DOORS (RESULTS FOR SMALL SPECIMENS, NOT FULL SIZE ELEMENTS AS REQUIRED FOR BS 476)



Ventilation
duct

FIG. 3. REPLACEABLE FIRE DAMPER

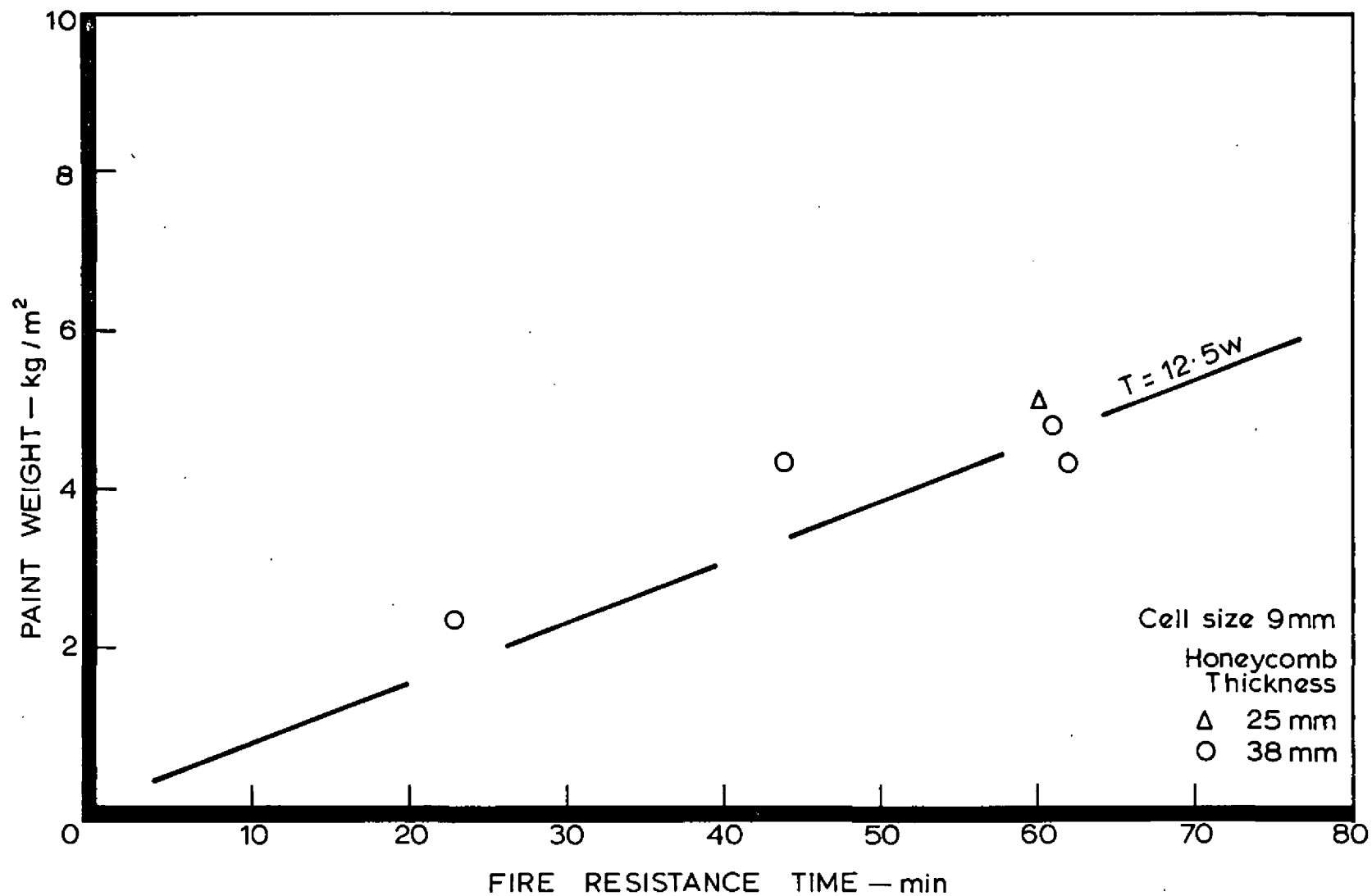

FIG. 4. FIRE RESISTANCE OF HONEYCOMB DAMPERS, (RESULTS FOR SMALL SPECIMENS NOT FULL SIZE ELEMENTS AS REQUIRED FOR BS 476)

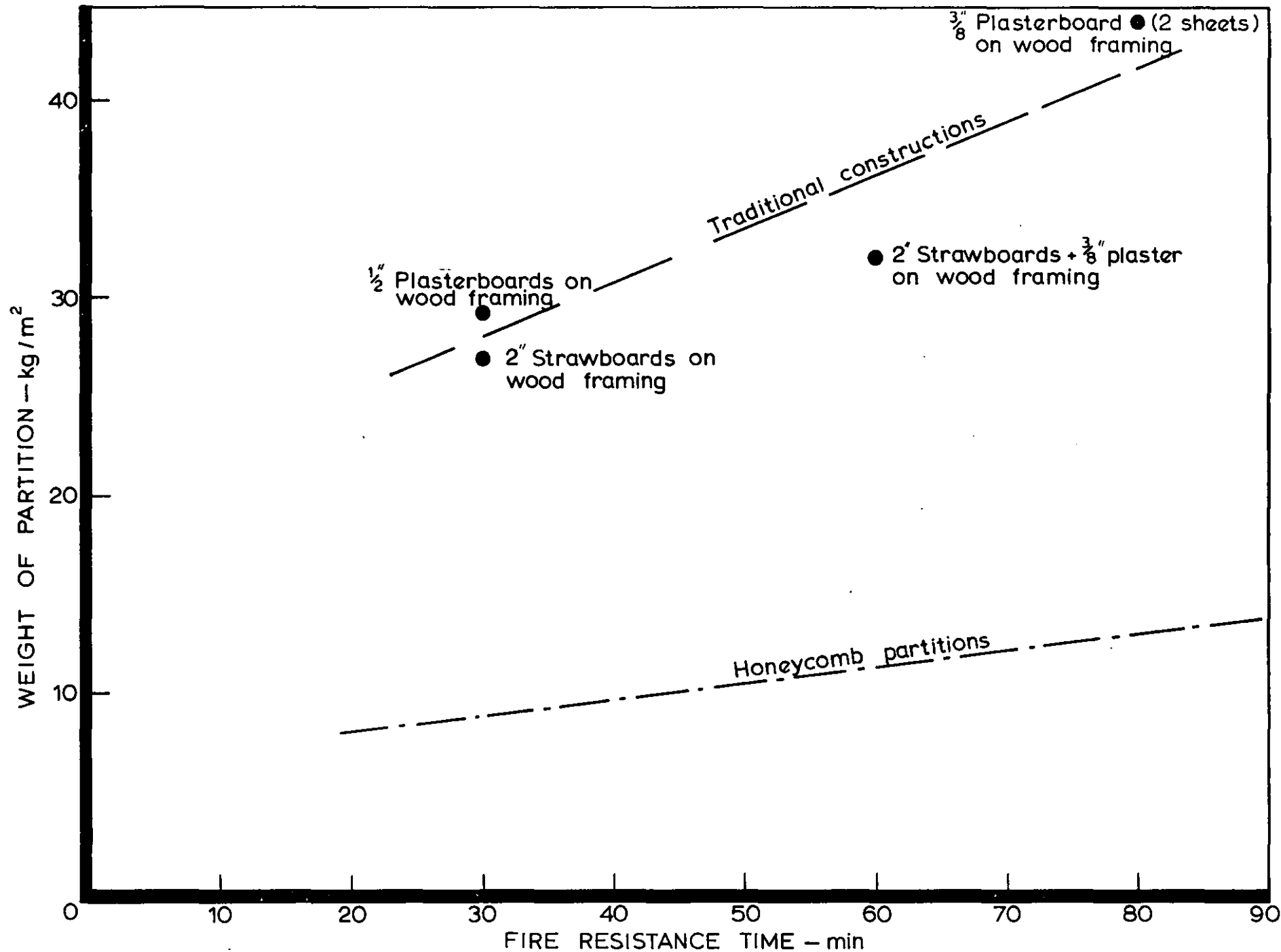
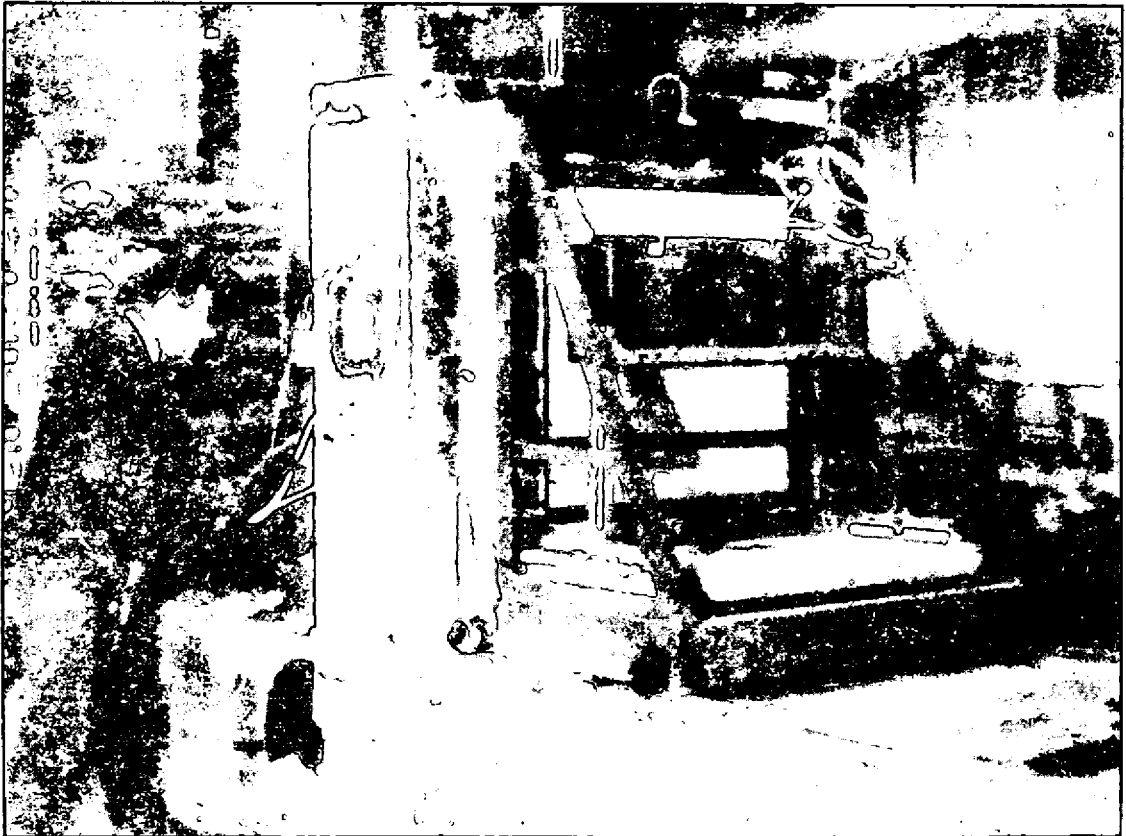

FIG. 5. COMPARISON BETWEEN WEIGHTS OF HONEYCOMB PARTITIONS AND TRADITIONAL CONSTRUCTIONS



GENERAL VIEW OF TEST FURNACE SHOWING PARTITION
SPECIMENS READY FOR TEST

PLATE 1



GENERAL VIEW OF TEST FURNACE SHOWING HONEYCOMB
FIRE DAMPER TEST IN PROGRESS

PLATE 1 (a)



(a) Furnace side before test

TEST OF PARTITION SPECIMENS

PLATE 2 (a)

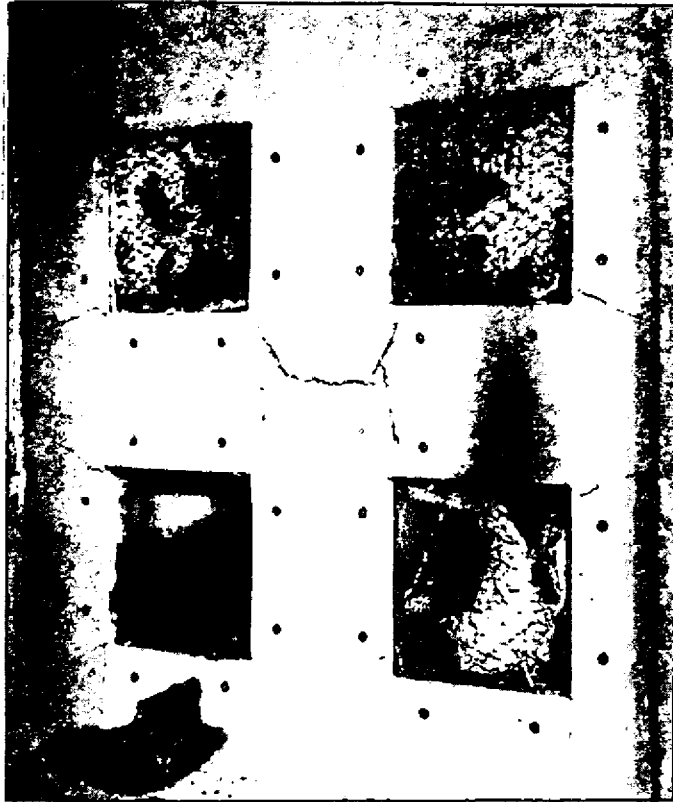

(b) Furnace side after test

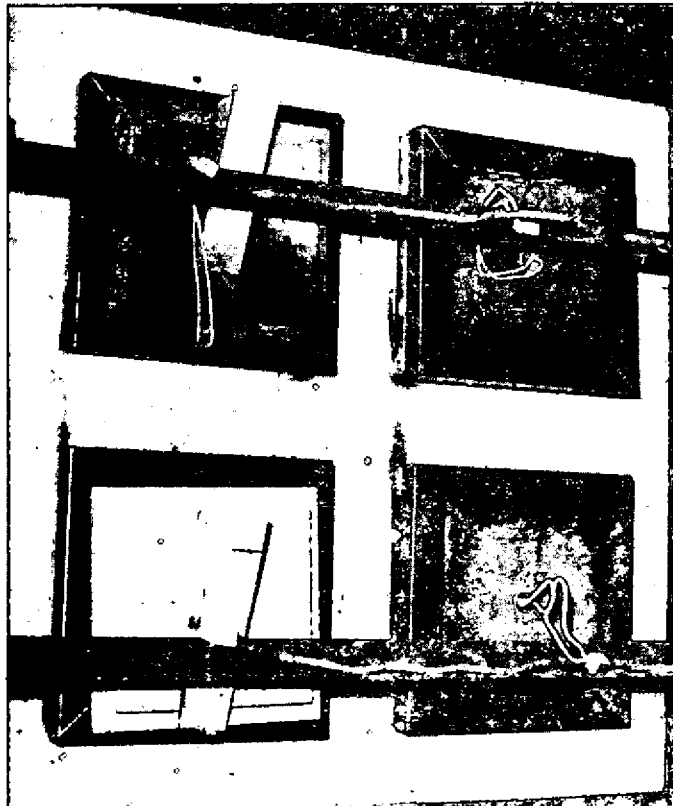

(c) Unexposed side after test

TEST OF PARTITION SPECIMENS

PLATE 2 (b) & (c)



DOOR SECTION BEFORE TEST

PLATE 3 (a)



(b) Furnace side

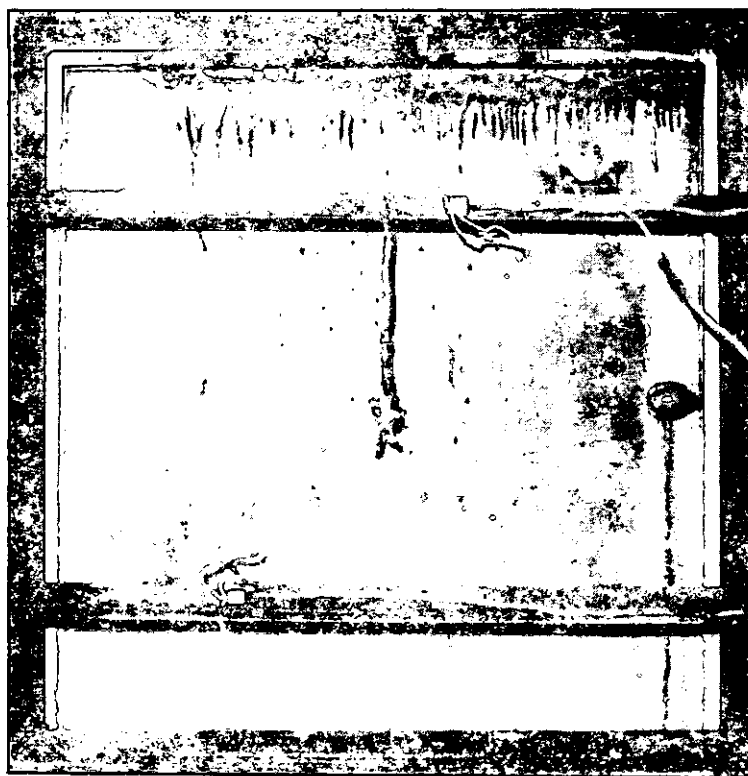

(c) Unexposed side

DOOR SECTION AFTER TEST

PLATE 3 (b) & (c)

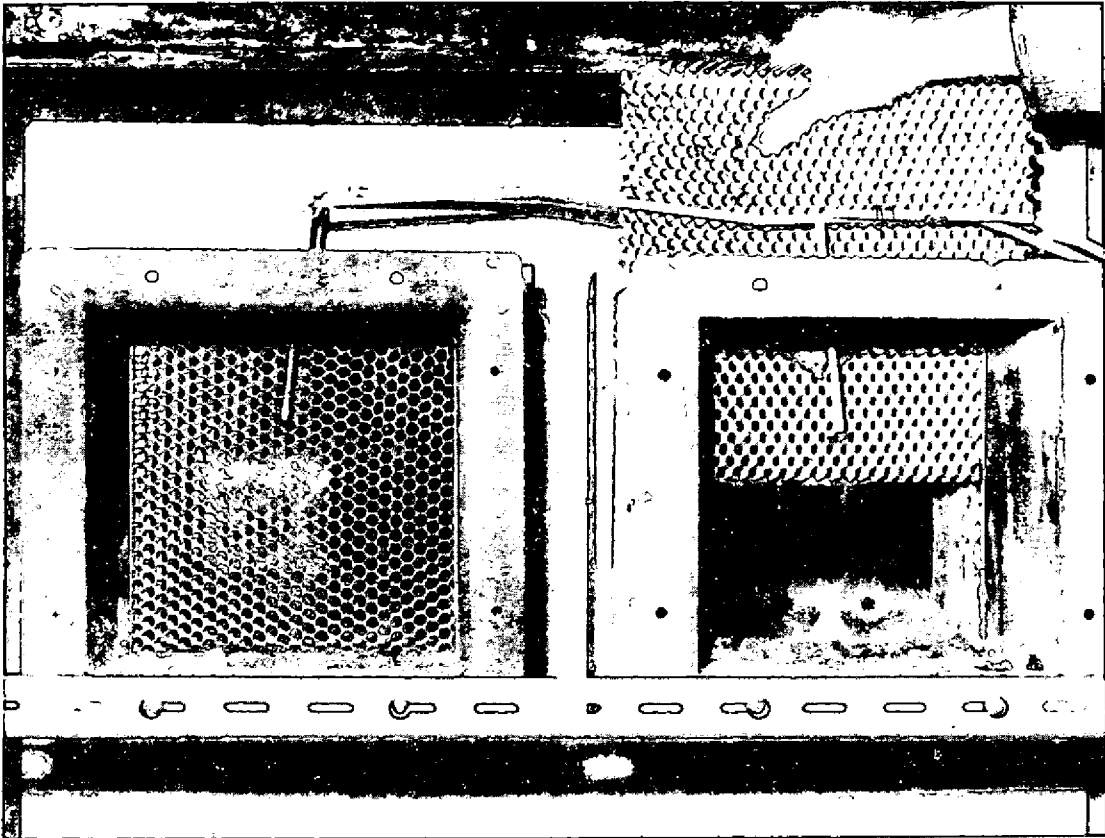

HONEYCOMB BEING PLACED IN POSITION IN
DUCT IN PREPARATION FOR TEST

PLATE 4

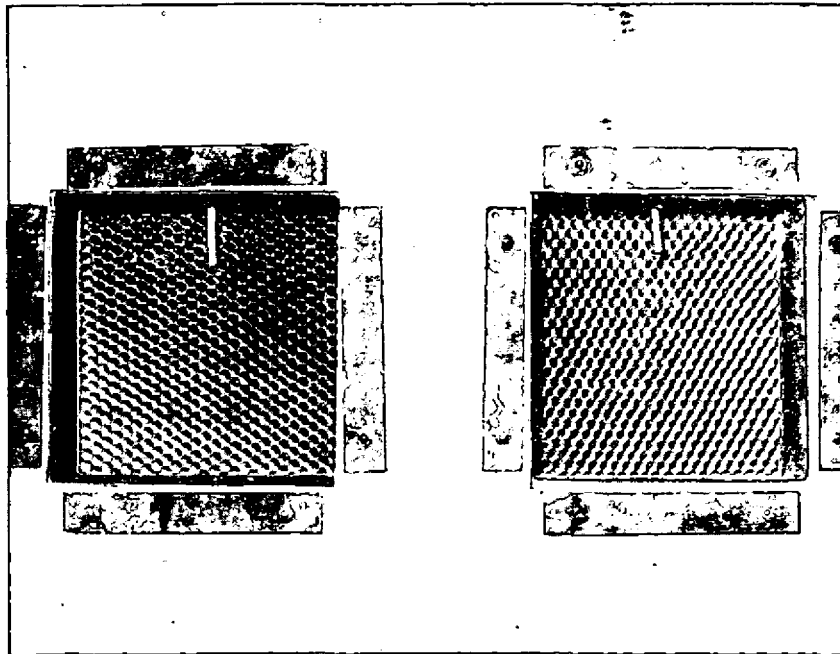

HONEYCOMB DAMPERS SEEN FROM
FURNACE SIDE BEFORE TEST

PLATE 5

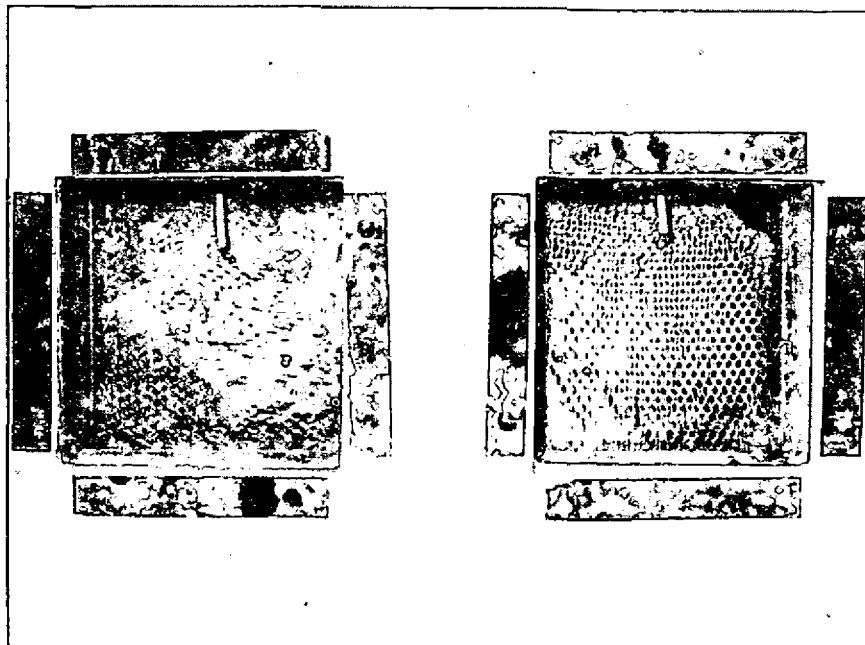

DAMPERS OF PLATE 5 AFTER TEST
SEEN FROM FURNACE SIDE

PLATE 6

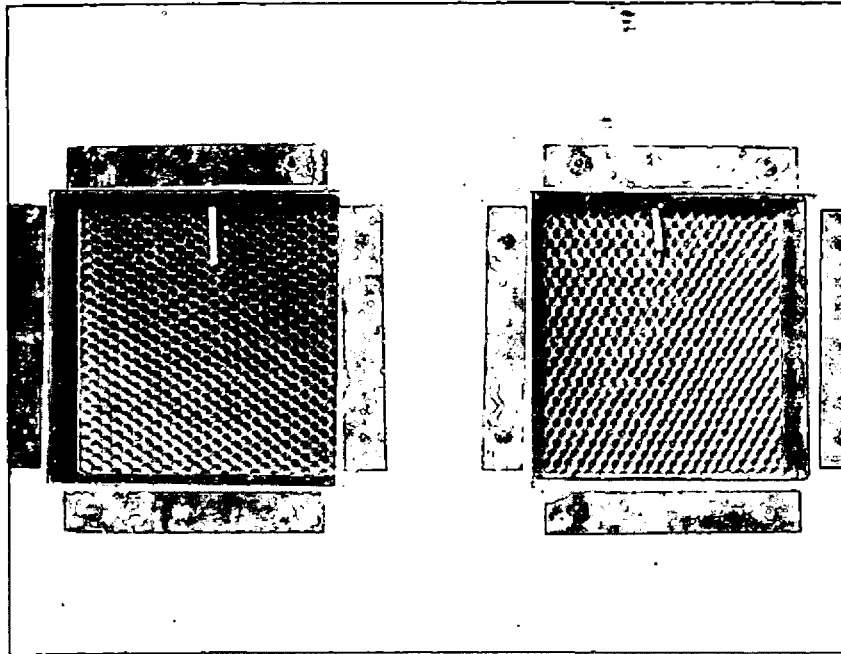

HONEYCOMB DAMPERS SEEN FROM
FURNACE SIDE BEFORE TEST

PLATE 5

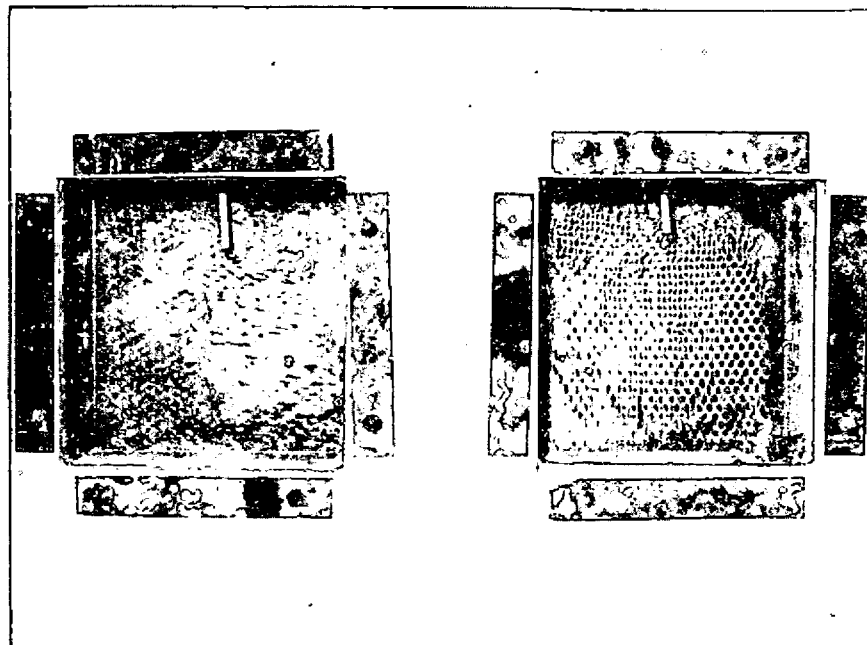

DAMPERS OF PLATE 5 AFTER TEST
SEEN FROM FURNACE SIDE

PLATE 6

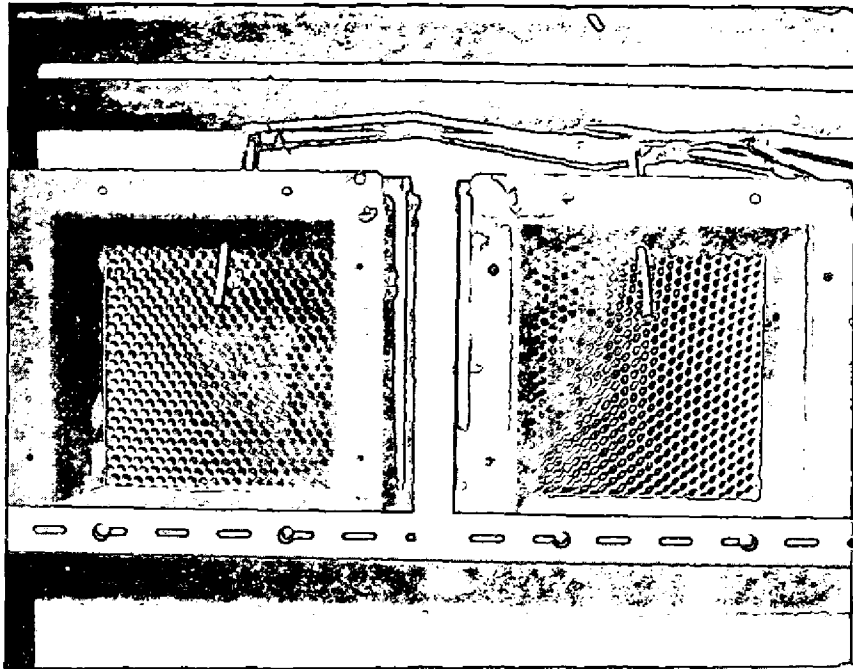

(a) Before test



(a) After test

DAMPERS SEEN FROM UNEXPOSED SIDE

PLATE 7



