



THE LIBRARY
FIRE RESEARCH STATION
BOREHAM WOOD
HERTS.
No. A99FR. N 944
32
11
72

Fire Research Note No. 944

**THE RAPID EXTINCTION OF FIRES IN
HIGH-RACKED STORAGEES**

by

P. NASH, N. W. BRIDGE and R. A. YOUNG

August 1972

FIRE RESEARCH STATION

Fire Research Station
Borehamwood
Herts
Tel. 01-953 6177

©

THE RAPID EXTINCTION OF FIRES IN HIGH-RACKED STORAGEES

by

P. Nash, N. W. Bridge and R. A. Young

SUMMARY

A quick-acting sprinkler system has been developed for the protection of racked storages. It consists essentially of a number of "zones" of open sprinkler heads, each zone of heads being each on the same vertical supply pipe which is fed from a horizontal mains supply pipe on the opening of a valve. The valve is operated by a line detector distributed throughout the racking within the protected "zone", so that a fire starting within the zone brings the appropriate sprinklers into action.

It has been shown experimentally that this system is very successful in detecting and controlling a fire during its very early stages, and some of the most difficult fires have been extinguished by it.

KEY WORDS: Storage, high-racked, sprinkler, system, extinguishing

Crown copyright

This report has not been published and should be considered as confidential advance information. No reference should be made to it in any publication without the written consent of the Director of Fire Research.

CONTENTS

INTRODUCTION

Part 1. Description of the quick acting sprinkler system

1. Main features of the system
2. The line detector
3. Water flow control
4. Additional facilities
 - 4.1. Monitoring
 - 4.2. Fire-warning
 - 4.3. Audible alarm
 - 4.4. Manual operation
 - 4.5. Neighbouring-zone operation
 - 4.6. Venting

Part 2. Experiments with quick acting sprinkler system

1. General description
2. Experimental arrangements
 - 2.1. Racking
 - 2.2. Pallets
 - 2.3. Sprinkler system
 - 2.4. Water supply
3. Stored goods and materials
 - 3.1. Steel drums in corrugated cardboard cartons
 - 3.2. Wood wool bales
 - 3.3. Polyurethane foam blocks
 - 3.4. Boxes of aerosols
 - 3.5. Foamed polythene reels
4. Instrumentation and detection equipment
 - 4.1. Temperature measurements
 - 4.2. Smoke detector
 - 4.3. Infra-red detector
5. Experimental procedure
6. Results
7. Conclusions

Table 1. Details of ignition points

Table 2. Results of experiments with quick acting sprinkler system

Part 3. Alternative systems

1. General
2. Igniter cord line detector
3. Water flow control
 - 3.1. Fuse-operation
 - 3.2. Electrical operation
4. Open circuiting line detectors
5. Frangible discs

REFERENCES

THE RAPID EXTINCTION OF FIRES IN HIGH-RACKED STORAGES

by

P. Nash, N. W. Bridge and R. A. Young

INTRODUCTION

The present annual direct loss due to fires in stored goods in warehouses in the United Kingdom is about £30 M¹. Large modern high-racked storages can contain several million pounds worth of goods, apart from the high cost of the storage building and its equipment. A fire in this type of warehouse can be disastrous not only because of the direct loss but also because of the disruption of manufacture and supplies. The extinction of such fires before they cause major damage is therefore of vital importance. The problem of fire control is very difficult because of the rapid vertical spread of fire which can occur in the well-ventilated spaces of a racked system. Previous experimental work on fires in racked storages in UK²⁻⁵, USA⁶, and Germany⁷ has been concerned with sprinklers distributed at intermediate levels within the racking and operated by the usual glass bulb or fusible link. The use of high expansion foam has also been studied⁸.

In nearly all these experiments, the fire has spread right through to the top of the racking, causing considerable fire, smoke and water damage. This occurs because the sprinklers generally operate after the flame has passed above them, although in one case, where the sprinkler operated ahead of the fire, the fire was stopped. After reaching the top of the rack, the fire has tended to spread horizontally beneath the ceiling, opening a number of ceiling-mounted sprinklers and causing additional water damage. While a system of ceiling and intermediate sprinklers is capable of containing a fire, it does not appear to be able to keep fire and water damage to a very low level.

A new approach to this problem is necessary in order to provide a more satisfactory solution to the fire problem, and a system has been designed which detects and extinguishes the fire in the slow initial stages of its growth. This system employs a line detector, of similar operating temperature to that of a sprinkler bulb, but distributed round the racking, in order to ensure that wherever the fire starts within the racking it will be detected, and water applied, before it grows beyond the initial stages.

The system can be designed to operate either individual sprinklers, or zones of sprinklers of any desired number from two upwards.

In paper presented at the FPA Conference on Fire Protection for High Bay Warehouses⁹, Nash suggested several operational requirements for a detection/ extinction system: these were:

- (a) The detection system should be capable of detecting a small fire anywhere in the storage system before it has time to spread beyond the first 'cell' of pallets in which it starts. This suggests a detection time of 0-2 mins for a normally developing fire.
- (b) The extinction system should be brought to bear on the fire in not more than, say, 1 minute after detection and should be capable of completely extinguishing the fire in not more than 8 minutes after detection, still within the cell of origin.
- (c) The detection/extinction system should not endanger personnel and should prevent the fire from so doing. It should keep the production of smoke to an absolute minimum.
- (d) The total system should be relatively cheap, and a cost figure was suggested not exceeding 10 per cent of the building and racking installation.
- (e) The system should be highly reliable and should 'fail safe' by giving warning if it is inoperative.

The system which is described in the first part of this paper meets these criteria in most respects, as can be seen from the results of the experiments reported in Part 2.

The cost of a complete system is not readily estimated at this stage. The system will provide a number of additional facilities, such as continued monitoring of the system with fault warning indication and manual operation of any zone, etc.

Part 1. Description of the quick acting sprinkler system

1. Main features of the system

The most important feature of the new arrangement of sprinklers is the division of the racking into "zones", each zone being protected by a group of open sprinklers. The size of zone used for the experiments at Cardington contained twelve standard sized pallet loads, two by two at each of three levels as shown in Fig. 1.

Each of the three 4-pallet cells is protected by one sprinkler head fitted on a vertical drop pipe passing through the centre of the cell. The drop pipe is supplied with water from the horizontal range pipe when a valve opens. This is achieved by an electrically fired explosive charge, which operates from a line detector.

The layout of the line detector within one zone is also shown in Fig.1.

Previous work^{4,5} had shown that a developing fire could be checked by opening at least one sprinkler ahead of the fire, and preferably two or more should be operated simultaneously. Since the racking at Cardington has six levels, it was decided to use two zones, with three sprinklers in each, to cover the full height. Half the length of the racking was converted to this arrangement giving a total of six zones as shown in Fig.2.

2. The line detector

The line detector used consists of a pair of steel wires, each insulated with a cellulosic layer, and the two twisted together. Further layers of insulation round the twisted pair give protection against mechanical damage, moisture, etc.

On heating to 68°C, the innermost layer of insulation melts, and a good contact is made between the two wires. This allows current to flow which fires the explosive device described below.

The circuit is shown in Fig.3, with the detector represented as a parallel pair.

No figures are available on the reliability of operation of the detector, but it is expected to be very reliable. This type of detector has been in use, mainly in USA, for about 30 years.

The resistance of the wire is about 10 ohms per conductor, for the length used in one zone, i.e. about 30 m (100 ft) and the additional resistance through the contact after operation is less than $\frac{1}{2}$ ohm.

3. Water flow control

The device used to allow water to flow from the 50 mm (2 in) horizontal range pipe into the 25 mm (1 in) drop pipe is a frangible disc made from nylon, with an electrically-fired miniature plastic detonator fixed in its housing as shown in Fig.4.

The outer diameter of the nylon disc is 50 mm (2 in) and the thickness is $12\frac{1}{2}$ mm ($\frac{1}{2}$ in) between radii of $12\frac{1}{2}$ mm and 25 mm. Over the central region, up to radius $12\frac{1}{2}$ mm, the thickness is reduced to 1.4 mm (.055 in). This region is blown out when the detonator fires, and the nylon bits are washed out through the

open sprinkler heads. They could be collected in a trap instead, if different types of nozzle were to be used.

Electrical characteristics of the detonator are given in Table 1. Other explosive devices used in alternative arrangements described in Part 3 have identical electrical characteristics.

Experience so far with the nylon disc is not sufficient to give accurate reliability data, though the discs used in the fire tests have operated each time. The detonator is of a standard type, and if it is supplied with sufficient current, the probability of firing is 99.9% at 99% confidence level¹⁰.

4. Additional facilities

4.1. Monitoring

Since the system uses an electrical detector and an electrically operated detonator, monitoring can easily be provided as shown in Fig.5. The current passed by the indicator must be low enough to prevent accidental firing of the explosive device. It has been found satisfactory to use a 6 V 40 mA bulb, in series with a suitable resistor to eliminate switch-on surges and to allow operation from a 24 V supply. If the bulb lights, continuity of both detonator and line detector is proved.

A short circuit in the indicator wiring could cause the frangible disc unit to fire, which is thus "fail safe", but steps should be taken to reduce this possibility.

4.2. A fire-warning light can be added to the circuit of Fig.5 as shown in Fig.6.

4.3. An audible alarm may be added so that operation of any zone causes its operation. Figure 7 shows a simple way of doing this with two alternative types of alarm. One could be an electronic alarm, or relay driving a bell, etc. The other is a small frangible disc unit, which on firing, allows gas to flow to a siren.

A zener diode is used in series with the small actuator, to prevent false indication of continuity.

4.4. Manual operation can be provided as shown in Fig.7 by means of push-buttons which can be located either on the indicator board, or at the bottom of the vertical set of zones which the buttons operate.

4.5. Automatic operation of neighbouring zones can be provided as soon as any one zone operates. For instance, a zone above the one which operates due to the fire may be operated using the circuit of Fig.8.

4.6. Venting and automatic smoke-stopping devices. The alarm circuit may be used to open roof vents automatically, but since the detector operates at an early stage of fire development, it is unlikely that venting will be necessary. Should, however venting be considered desirable, it could be operated in conjunction with an inflatable smoke-stopping device, which projects down into an aisle from the roof when inflated. A pair of such devices, one each side of the fire zone, could effectively channel the smoke upwards through the vent, and prevent its spread to other, unaffected parts of the building.

An automatic call to the fire brigade may also be initiated by the alarm circuit.

Table 1

Electrical characteristics of explosive actuators

| | |
|----------------------------|---|
| No fire current | 0.275A minimum (.01% probability, 95% confidence) |
| All fire current | 0.48A continuously applied |
| | 0.80A for 10 ms |
| All fire energy | 6 mJ applied in less than 10 ms |
| Recommended firing current | 1A min |
| Resistance | 0.9 - 1.6 Ω |
| Functioning time | Not greater than 30 ms at 0.55A |
| | Approx 2 ms at 2.0A |

Part 2. Experiments with quick-acting sprinkler system

1. General description

A series of seven experiments was made in which the system, as described in Part 1, controlled or extinguished fires in a variety of materials. The experiments were designed to provide a severe test of the system against goods known to produce rapidly-developing fires or fires which are difficult to extinguish.

The goods ranged from Category 1 to Category 4 of the Extra High Hazard, High Piled Storage Risks as classified in the 29th Edition of the FOC Rules for Automatic Sprinkler systems.

2. Experimental arrangements

The basic experimental arrangements were the same as thos which were used for the previous series of large scale tests at Cardington³ so that a direct comparison of the results could be made.

2.1. Racking

Half the length of the main rack was used, being 11.4 m (37.3 ft) in height and 8.5 m (28 ft) in length, providing 72 pallet spaces, in two rows (back to back), on six levels. At each level, the vertical columns of the rack divided it into three sections, each providing space for 4 pallets, 2 x 2 back to back. The dimensions of each section or 'cell' were (9 ft x 7 ft x 6 ft) high.

2.2. Pallets

Standard wooden 4-way entry pallets, 1020 x 1220 mm (40 x 48 in) were used in all experiments.

2.3. Sprinkler system

The system used was that described previously and was arranged in the rack to protect 6 zones, each zone being 1 cell in area, 3 cells in height (Fig.2). The operation of the grangible disc in one zone by the detector system fixed at each level in that zone, would allow water to flow to three 15 mm ($\frac{1}{2}$ in) open conventional sprinklers.

Main water supply pipes 50 mm (2 in) diameter were fixed horizontally along the central longitudinal axis of the rack at the top of the third and sixth levels. Three vertical supply pipes were dropped from each of these through the centre of each cell and were of 25 mm (1 in) diameter.

2.4. Water supply

Water was supplied to the main horizontal feeds, via a manifold, from a petrol-driven pump capable of delivering 4.1 m³/min (900 gallons/min). Throughout each test the pressure was maintained at 5b (72 lbf/in²) with 1 zone in operation. In the test where 2 zones operated, the pressure was reduced to 4b (58 lbf/in²), in order to simulate approximately the pressure/flow characteristics of an ordinary sprinkler system.

3. Stored goods and materials

3.1. Steel drums in corrugated cardboard cartons

The first three experiments were made with all 72 pallets filled with this load. This was done in order to make direct comparisons with previous work with the same load and to investigate the effect of different ignition points on the detection time. In each of the three experiments the 710 x 460 x 460 mm (28 x 18 x 18 in) cartons contained 3 empty 5 gallon drums, packed in wood wool, and arranged 9 to a pallet.

3.2. Wood wool bales

Three pallet loads of cartons were replaced by pallets loaded with four $\frac{1}{2}$ cwt bales of wood wool. These were positioned, one on the right hand side of the front face of the central bottom level cell, and two on the front face of the cell above. This was considered to be sufficient, as the system would have been considered to have failed if the fire spread to the second level.

3.3. Polyurethane foam blocks

Four pallets were loaded with the foam blocks, which were each 460 x 460 x 80 mm high (18 x 18 x 3 in high). The blocks were placed in four stacks on the pallet, each stack being of 12 blocks 0.9 m (36 in) high. The pallets were placed on the front face of the central zone, on the bottom and second levels only.

3.4. Boxes of aerosols

The same four pallets as above were each loaded with 125 cardboard boxes each containing 12 aerosol cans of fly killer. The boxes covered the whole area of each pallet and were stacked to a height of 1.2 m (48 in).

3.5. Foamed polythene reels

The reels of foamed polythene, a wallpaper substitute, were stood vertically 3 to a pallet, each reel being approximately 510 mm (20 in) diameter and 760 mm (30 in) high. The same four pallet spaces were filled with this load as in 3.3 above.

4. Instrumentation and detection equipment

4.1. Temperature measurements

The temperature was measured with fine wire thermocouples on the front face of the central cells on the 1st, 3rd and 5th levels, at the centre of the control cells on the 2nd, 4th and 6th levels. The output from the thermocouples was recorded on a multi-channel U.V. recorder.

4.2. Smoke detector

An ionisation-chamber type smoke detector was installed at a height of 13.7 m (45 ft) above the centre of the central cells, and connected to control and indicating equipment. The time at which the detector operated was recorded.

4.3. Infra-red detector

An infra-red fire detector was fixed at a height of 13.7 m (45 ft) at a distance of 1 m (3.3 ft) out from the front face of the rack, and 3 m

(9.8 ft) from the centre of the central cell. This was connected to the same control equipment as the smoke detector.

5. Experimental procedure

Before each fire was lit, the air temperature and humidity at ground level were measured, together with the moisture content of cardboard boxes within the rack. The depth of water in the supply tank was measured and the sprinkler system pressurised. The power supply to the line detector and frangible unit was switched on and the control unit observed to check that each zone was operational.

In the experiments 1, 2 and 3 the fire was started by lighting the torn edge of a cardboard box in the positions detailed in Table 2.

In experiments 4, 6 and 7 about 2 lb of wood-wool was lit on the floor under the centre of a loaded pallet. In the fifth experiment⁵, the base of one of the stacks of polyurethane foam was lit with a match.

Photographs were taken at timed intervals of the progress of the fire in each experiment, and the flame height was recorded against time.

The operating time of the line detector which was also coincident with the time of operation of the frangible disc and the application of the water was recorded.

In the experiments 2 and 6 the fire was completely extinguished by the sprinklers. In the remaining experiments, when it was clear that the fire was under control with no possibility of further spread, a hose-reel jet was used to complete extinction.

At the end of each experiment the quantity of water delivered by the system was calculated from the change in depth of the water in the supply tank.

6. Results

- 6.1. Maximum flame height reached in any test was 2.4 m (8 ft).
- 6.2. Maximum damage to goods by fire was 2 pallet loads.
- 6.3. Twelve pallet loads were wetted in 6 tests, and in the other test 24 pallet loads were wetted.
- 6.4. Negligible amounts of smoke were produced, even in tests involving plastic materials.
- 6.5. The average volume of water used was approximately 2.8 m³ (630 gal).

6.6. The maximum duration of any experiment was 11 min 15 s.

6.7. The time taken to renew the line detector and to replace the frangible disc was about 30 min.

6.8. The maximum air temperature recorded was 190°C, which was maintained for a period of 15 s in Experiment 5. This was measured on the front face of the rack in the 1st level.

The results are shown in more detail in Table 3.

7. Conclusions

This series of experiments has provided useful information on the effectiveness of the proposed rapid-acting sprinkler system in extinguishing fires in a variety of goods in racked storages. It has shown that:

7.1. A system can be designed to prevent fires spreading from the cell in which they originate, no matter what the nature of the stored goods within the FOC classification.

7.2. Potentially serious fires can be controlled with a very small volume of water, the maximum used in any experiment being 5.7 m³ (1260 gallons). This suggests that the extra cost of the line detector system could be offset against smaller costs for water storage facilities.

7.3. The volume of smoke produced, even in the experiments involving plastics, was negligible, and would not have prevented access to the rack by Fire Brigade personnel nor caused significant smoke damage outside the fire area.

7.4. The use of a quick-acting sprinkler system combining a robust and relatively insensitive line detector with an explosively-operated valve and open sprinklers, provides a complete answer to the problem of controlling fires in racked storages with the minimum of water, smoke and fire damage. It also provides a system in which replacement is quick and easy so that the storage can be in use again with minimum delay. Other additional facilities can readily be provided.

7.5. No distortion of the racking was detected at any time, so the racking could be used again immediately.

Table 2

Details of ignition points

All fires were lit in the central cell at the first level

| Experiment No. | Ignition point |
|----------------|--|
| 1 | A. Box torn (1 ft from front face in gap between pallets on face of bottom level cell. |
| 2 | B. Box torn (2 ft 6 in) in gap as above. |
| 3 | C. Box torn in centre of one pallet load on the front face. |
| 4 | D. 2 lb of wood wool on floor under centre of pallet containing wood wool. |
| 5 | E. Base of stack of polyurethane foam, half way into centre of rack, in gap between pallets. |
| 6 | D. As above. |
| 7 | D. As above. |

Table 3. Results of experiments with quick-acting sprinkler system

| Test No. | Combustibles | Ignition point | Frangible disc operating time | | Flame height maximum m (ft) | Duration of water application | | Point detector operating times | | Volume of water used m ³ (gal) |
|----------|--------------------------------|----------------|-------------------------------|-----|--------------------------------|-------------------------------|-----|--------------------------------|-------------------------------|--|
| | | | min | sec | | min | sec | Infra-red min sec | Ionisation chamber min sec | |
| 1 | Steel drums in cardboard boxes | A | 2 | 40 | 1.2 (4) | 1 | 35 | N.O. | N.O. | 1.4 (310) |
| 2 | " | B | 8 | 43 | 2.1 (7) | | 37 | N.O. | 8 43 | 0.3 (74) |
| 3 | " | C | 7 | 15 | 1.8 (6) | 3 | 45 | 6 04 | 5 50 | 2.2 (490) |
| 4 | Wood wool bales | D | | 50 | 2.4 (8) | 5 | 10 | 1 10 | 1 10 | 3.5 (780) |
| 5 | Polyurethane foam blocks | E | 1 | 28 | 2.1 (7) | 9 | 32 | N.O. | N.O. | 4.1 (900) |
| 6 | Aerosols | D | 5 | 05* | 2.4 (8) | 6 | 10* | N.O. | 4 02 | 5.7 (1260) |
| | | | 5 | 10 | | 6 | 05 | | | |
| 7 | Polythene foam reels | D | 2 | 05 | 2.1 (7) | 4 | 55 | 2 10 | 1 40 | 2.8 (625) |

*Fire started at the edge of this zone, bringing two zones into operation

Part 3. Alternative systems

1. General

An entirely non-electrical form of the system has also been used successfully on a number of experimental fires, including polyurethane foam blocks.

2. Igniter cord line detector

The line detector used was a fast burning cord, distributed round the zone in a slightly simpler form than that shown in Fig.1. "Igniter cord" is normally used to fire charges for quarrying etc. It consists of a paper string, impregnated with black powder, and surrounded with an ignitable composition. The whole is sheathed with polythene of about $\frac{1}{8}$ mm (.005 in) thickness, giving a flexible cord, about 3 mm diameter, which will ignite when heated to about 170°C. It will then burn (in both directions from the ignition point) at about 30 cm/sec (1 ft/sec). For each zone, about 60 ft of cord was used.

3. Water flow control

3.1. The water flow device was a modified multiple jet control valve, shown in Fig.9. The original glass bulb is retained in the special fitting and gives the valve a second chance to operate if the line detector/explosive charge fails to work. Normally, the igniter cord will burn up to the device well in advance of the fire, and ignite the black powder charge through the small interconnecting hole. The strut is then blown off, allowing the other parts to fall away, and water to pass through the valve.

This can also be applied to individual sprinkler heads, which might then replace some heads in systems already in use, to give increased speed of operation without increasing temperature sensitivity of any part of the system.

This form of the system has a disadvantage in that it cannot easily be monitored like the electrical system, but on the other hand it needs no power supplies.

The igniter cord can also absorb water slowly, by diffusion through the plastic coating, and this causes a great reduction in burning rate which would defeat the object of using the cord. It seems likely that this detector could be used in temporary systems, and particularly in low-humidity environments.

3.2. The double acting valve unit of Fig.9 can be modified to use another form of electrically-fired explosive device, as shown in Fig.10. The explosion causes a small piston to move out about 3 mm against the strut, which is dislodged allowing the water to flow.

4. Open circuiting line detectors

Any of the electrically fired explosive devices may be used with a line detector which produces an open-circuit, or at least a large increase in resistance, instead of the previously described short-circuiting type. A circuit for this is shown in Fig.11, with monitoring lamps added. Operation of the circuit is as follows.

The resistor R passes enough current to trigger the thyristor into conduction, but this is normally bypassed through the line detector. When the resistance of the line detector increases sufficiently, the current fed to the thyristor gate fires it, and hence the explosive device.

One possible form of line detector is a slow igniter cord, which has a central wire of aluminium to give the initial low resistance. The ignitable composition is applied at intervals along the wire, so that sensitivity is not appreciably reduced, but ignition of one section will not cause the entire cord to burn out, as it would if the composition were continuous. When any part of the composition is ignited it burns through the wire, giving an open circuit.

Another possible form of open circuiting detector is a plastic cord plated with an electrically conducting, but mechanically weak, coating. When the plastic melts, it ruptures the coating to give a large increase in resistance.

A possible defence against mechanical damage to this type of line detector is the use of two lines, electrically in parallel, positioned in the racking on either side of a structural member, so that a fire would operate both lines in quick succession, but mechanical damage to both simultaneously is unlikely.

5. Frangible discs

An alternative form of frangible disc is a glass disc, shattered by a piston actuator having a sharp or chisel point. This has not yet been used in experimental fires, but is under active development. This may be a more practicable form of frangible disc from the installation point of view, since the piston actuators can be replaced, or removed for test firing, etc, without having to drain any part of the system.

REFERENCES

1. Fire Protection Association. Fire Prevention No.93, p.27. December 1971.
2. YOUNG, R. A. Fire tests with sprinklers on high piled stock. Fire Research Note 814. March 1970.

3. NASH, P. BRIDGE, N. W. and YOUNG, R. A. Some experimental studies of the control of a developing fire in high racked storages by a sprinkler system. Fire Research Note No.866. April 1971.
4. NASH, P., BRIDGE, N. W. and YOUNG, R. A. Experiments with sprinklers in high racked storages (2) Extinction with face mounted sprinkler. Fire Research Note No.914. January 1972.
5. NASH, P., BRIDGE, N. W. and YOUNG, R. A. Experiments with sprinklers in high racked storages (1) Extinction with centrally mounted sprinklers. Fire Research Note No.916. January 1972.
6. Factory Mutual Research Corporation. Rack storage fire protection committee report.
7. Walther & Cie. Report on tests of Walther sprinkler systems. KÖln-Dellbrück, May 1970.
8. NASH, P., BRIDGE, N. W. and YOUNG, R. A. The extinction of fires in storages of racked goods using high expansion foam. Fire Research Note No.857. January 1971.
9. NASH, P. Control of fire in high racked storages. Fire Protection Association 1970.
10. Private communication from Nobels Explosives Co Ltd.

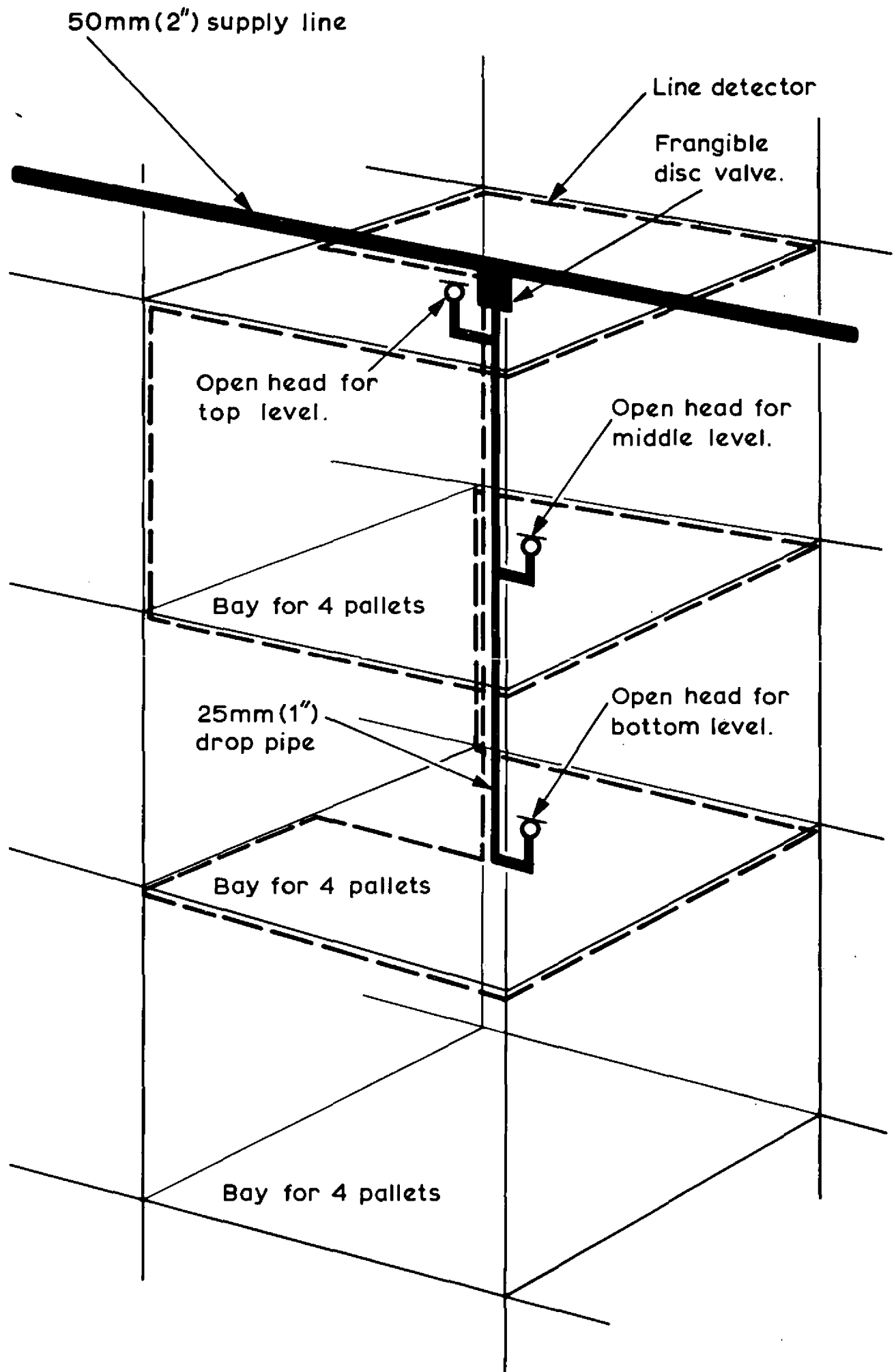

FIG.1 LAYOUT OF PIPEWORK & LINE DETECTOR IN RACKING, FOR 1 ZONE.

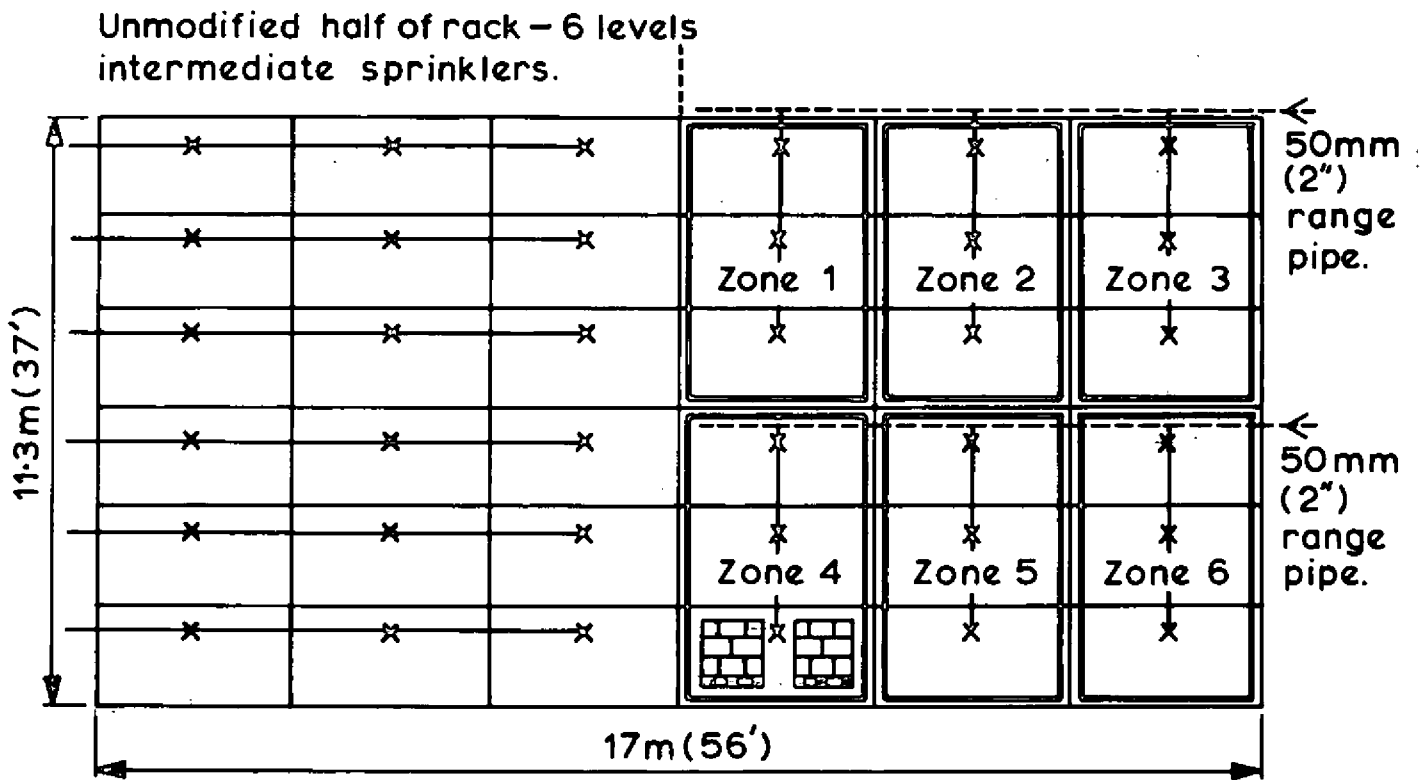

FIG. 2 FRONT ELEVATION OF RACKING SHOWING 6 ZONES.

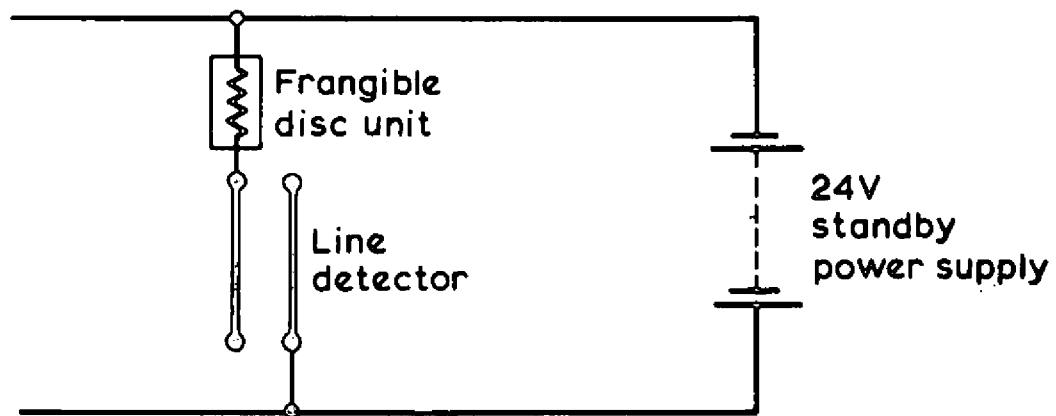

FIG 3. BASIC CIRCUIT FOR 1 ZONE

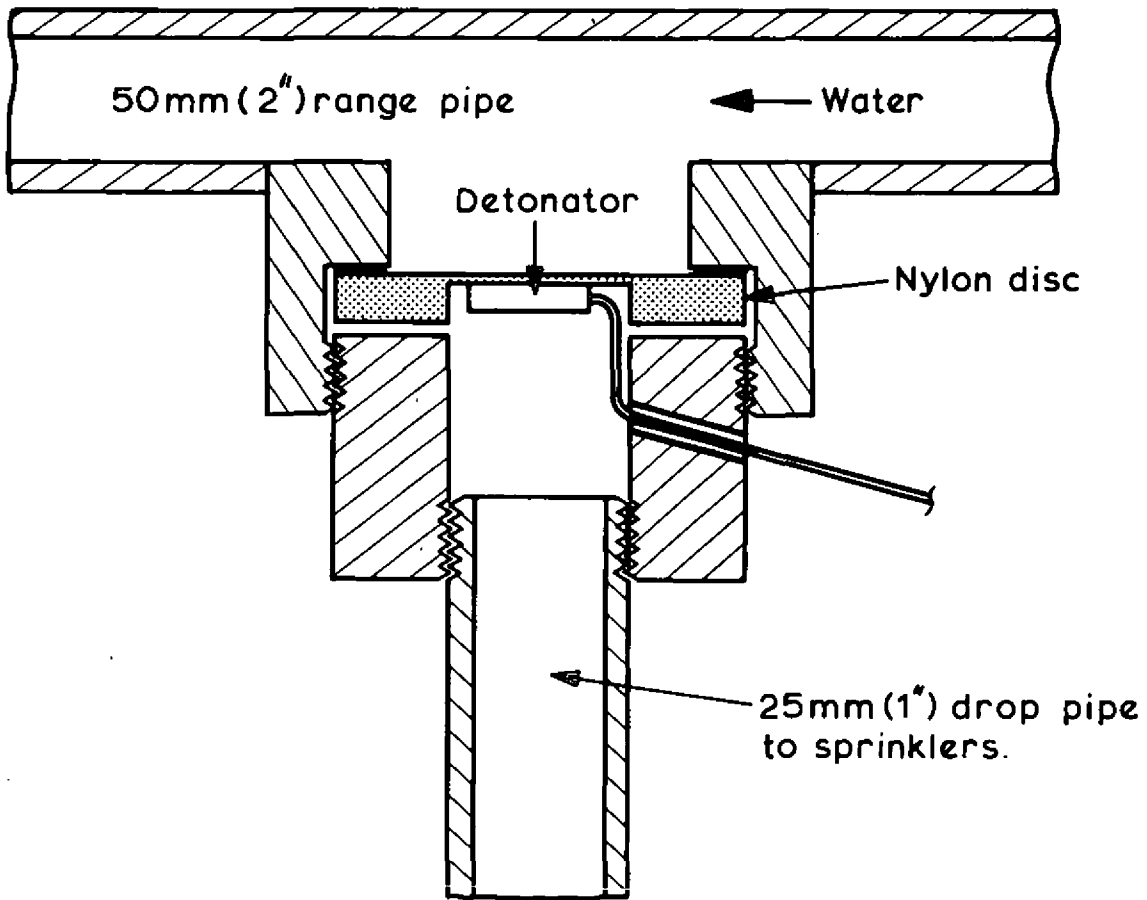

FIG.4 NYLON FRANGIBLE DISC IN HOUSING.

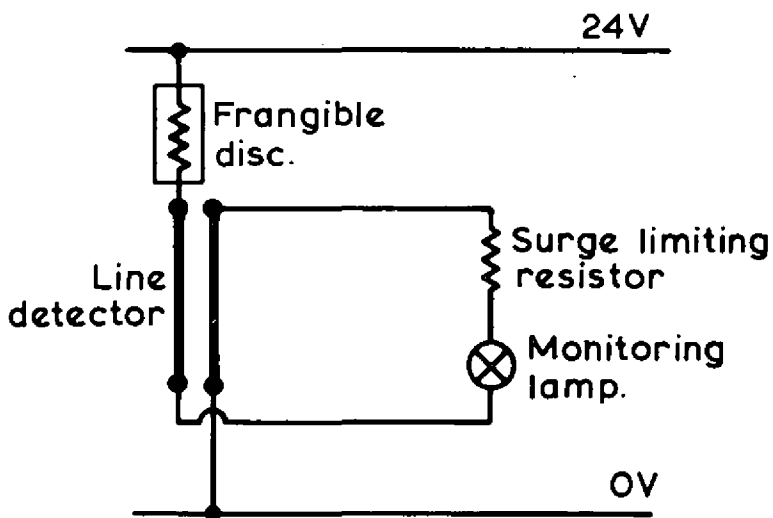

FIG.5 BASIC CIRCUIT & MONITORING.

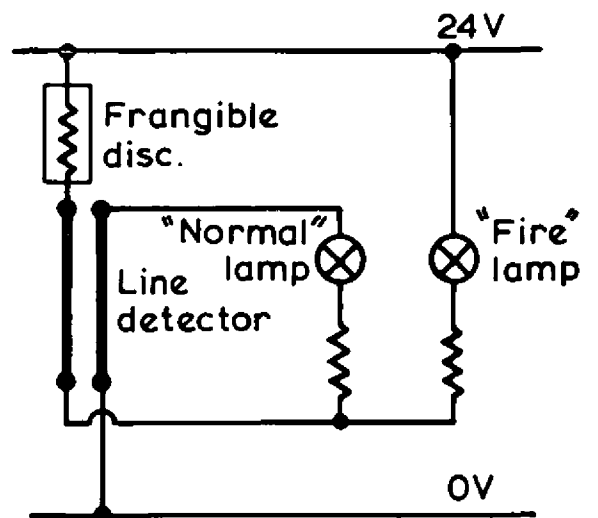

FIG.6 BASIC CIRCUIT & MONITORING & ALARM LAMP.

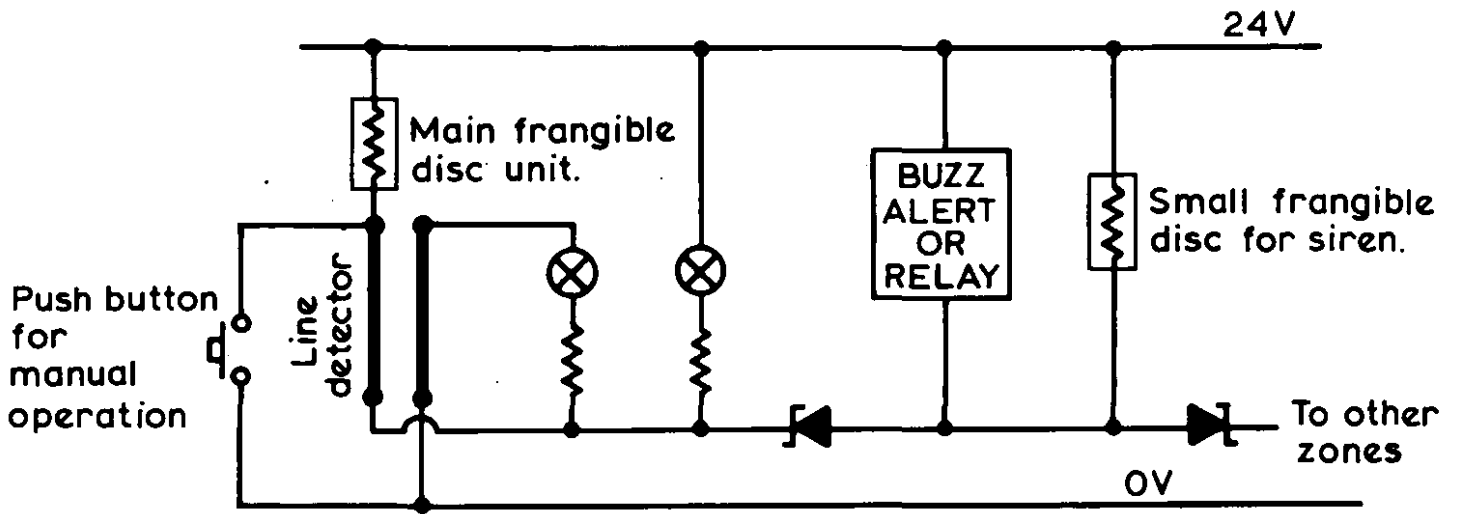

FIG.7 ADDITION OF AUDIBLE & VISUAL ALARMS, AND MANUAL OPERATION.

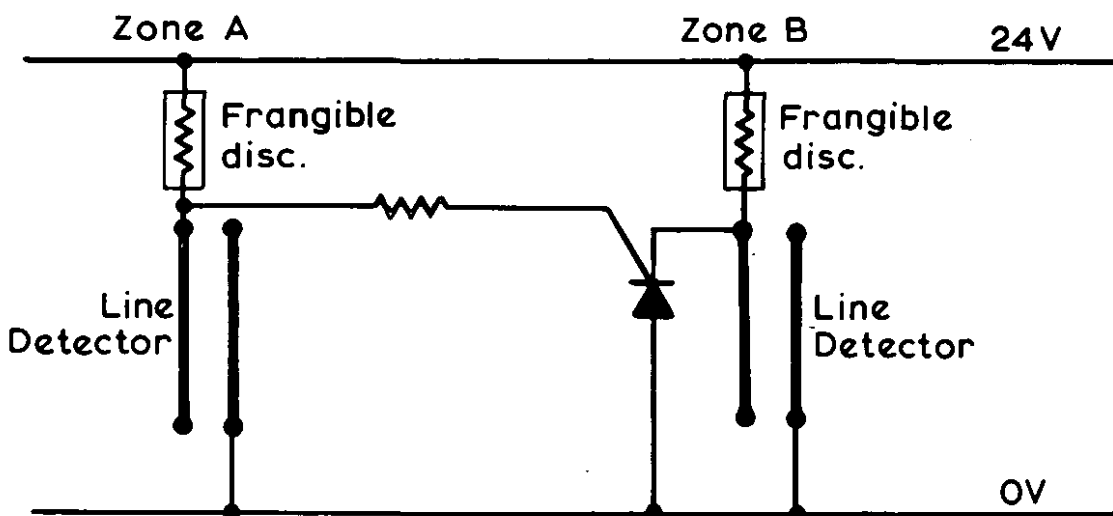

FIG.8 ONE METHOD FOR AUTOMATICALLY FIRING ONE ZONE FROM ANOTHER.

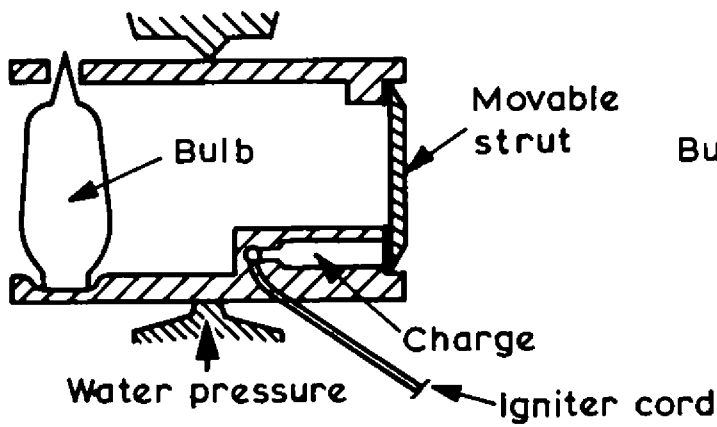

FIG.9 DOUBLE-ACTING
MULTIPLE JET
CONTROL.
(BLACK POWDER CHARGE TYPE)

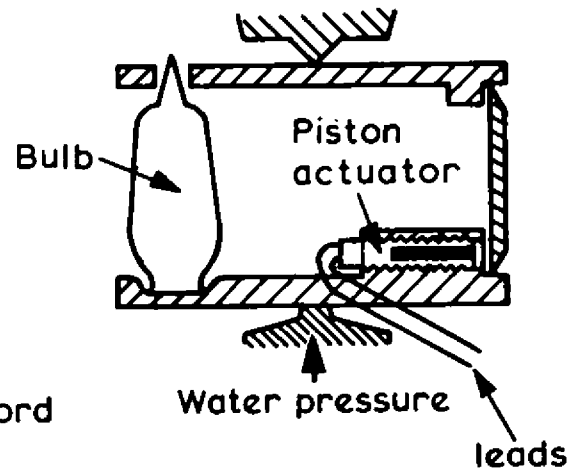

FIG.10 DOUBLE-ACTING
MULTIPLE JET
CONTROL.
(PISTON ACTUATOR TYPE.)

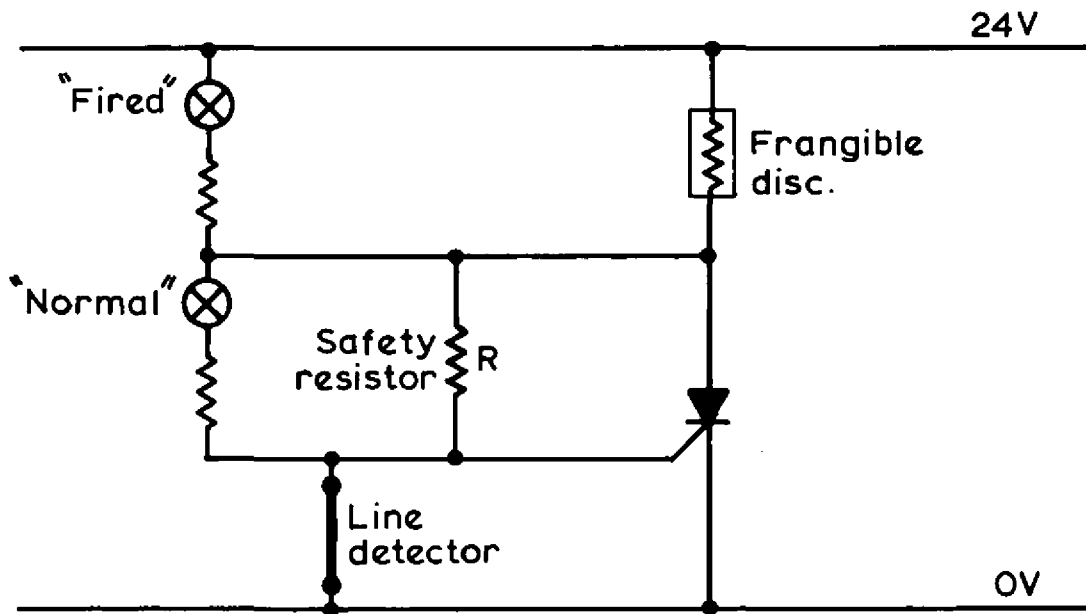

FIG.11 CIRCUIT FOR OPEN CIRCUITING
DETECTOR.