

Delayed Extinction of Flames Spreading Downward over Paper Sheets

KEIJI TAKENO and TOSHISUKE HIRANO

Department of Reaction Chemistry
The University of Tokyo
Tokyo, Japan

ABSTRACT

The mechanisms of delayed extinction of flames spreading downward over paper sheets have been explored experimentally. The transient temperature fields near spreading flames were examined using schlieren photography and fine thermocouples. Just after an instantaneous increase of free-stream velocity, the flame was observed to approach the pyrolysis zone and its length increased. At the same time, the temperature of the pyrolysis zone surface started to increase at the rate of several hundreds °C/s. Then, the flame turned away from the pyrolysis zone surface and finally became small to extinction. At a few tens ms after the velocity increase, the temperature of the pyrolysis zone surface reached its maximum of several tens °C higher than that before the free stream velocity increase. Based on the experimental results, the heat transfer process of delayed extinction has been discussed in detail. The phenomena to be considered for the theoretical prediction of rate or limit of flame spread were elucidated.

INTRODUCTION

Flame spread over various combustible materials is basic knowledge for better understanding of the process of fire development, so that a number of studies on it have been performed [1-9]. Through these studies, the mechanisms of flame spread have been explored to a greater extent and several excellent models of flame spread have been proposed.

At real fires, the profiles of temperature, velocity, concentration of oxygen, and pressure of ambient air stream scarcely stay to be steady. Flame spread phenomena must be largely influenced by the changes of these surrounding conditions. However, most of the previous studies on flame spread over combustible materials are concerned with flame spread under steady conditions. Only a few studies have concerned with the flame spread under unsteady conditions.

Typical problems of unsteady flame spread are concerning the limit for flame spread and the transition to extinction[10-14]. Various groups have studied the flame spread limit. Hirano et al.[10] have examined the stream lines and the temperature distributions adjacent to the downward spreading flame and shown that the flame spread phenomena near blow-off limit depend mainly on the velocity component of the free-stream normal

to the leading flame edge. Frey and T'ien[12] have measured the flame spread rates and the temperature profiles under the conditions very close to extinction. Also, Altenkirch et al.[14] have examined the buoyancy effects on downward flame spread near the extinction limit. In the latter two studies, the power-law correlations established in the stable flame spread were shown not to remain valid near the extinction limit. Kodama et al.[15] have numerically analyzed the process of convective extinction of spreading diffusion flame and presented the distributions of gas temperature, velocity, and concentrations of fuel and oxygen near the flame spread limit. In these studies, the extinction phenomena have been considered to be predictable by assuming quasi-steady states.

In very few studies, the transient processes of flame spread have been examined. Sato et al.[16] experimentally examined the extinction phenomena of a downward spreading flame over paper sheets with a velocity change of an air stream and have pointed out that the spreading flame behavior depended not only on the free-stream velocity but also on its changing rate. However, their study was at its first stage and no information on the heat transfer from the gas to solid was obtained, so that the process of extinction of spreading flames at a velocity increase is still ambiguous.

In the study of Sato et al.[16], two modes of extinction were observed when the free-stream velocity u_{∞} was instantaneously increased from that for stable flame spread. One was delayed extinction caused by the consumption of the pyrolysis zone, and the other was instantaneous extinction caused by the high air stream velocity near the leading flame edge. In the present study, the mechanisms of delayed extinction of flames spreading downward over paper sheets have been explored experimentally. The transient temperature fields near spreading flames were examined using schlieren photography and fine thermocouples.

EXPERIMENTAL APPARATUS AND PROCEDURES

The flame spread experiments were performed in a rectangular vertical combustion chamber shown in Fig.1, the inside of which was 4.5x4.5 cm cross section and 10.0 cm long, which was mounted on a converging nozzle of a wind tunnel. For examining the phenomena by direct or schlieren photography, optical Pyrex plates were fitted to the two opposed walls of the chamber. The air stream flowing upward in the combustion chamber was generated by a blower. The test pieces of combustible solid used in the experiments were the filter paper sheets of 0.026 and 0.05 cm thick. The test pieces cut in 4.5x10.0 cm surface area were dried for more than 24 hrs in a desiccator and placed at the center of chamber, being vertical to the optical Pyrex window with supported by several fine wires.

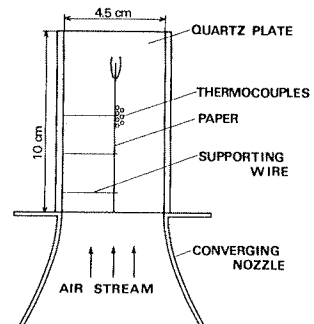

Fig.1 Vertical combustion chamber

Ignition was performed at the downstream end of the paper sheet using a heated nichrome wire. The air stream velocity was started to change when the leading flame edge passed at 5.0 cm from the upstream end

of paper sheet. The transient behavior of flame spread after change of air stream velocity was recorded using a 16 mm high-speed schlieren system composed of a high pressure 500 W mercury vapor lamp, two concave mirrors of 10 cm in diameter (100 cm in focal length), a knife edge, and a high speed camera. The temperature distributions were measured by 0.05 mm Pt-PtRh(13%) thermocouples installed in and out of touch with the paper surface. The precise positions of thermocouples were examined by analyzing photographs taken by a motor-driven 35 mm camera.

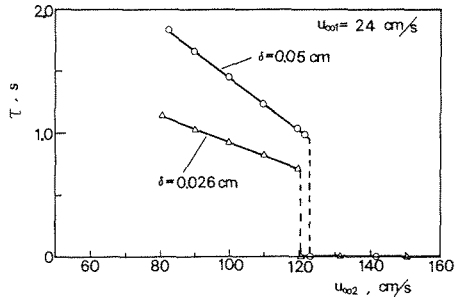

Fig.2 Variations of τ with $u_{\infty 2}$

RESULTS AND DISCUSSION

Aspects of Extinction

It has been shown in previous studies[7,8,10,11,16] that the rate of downward flame spread, V_f , depends on the upward free-stream velocity u_{∞} . As u_{∞} is increased, the flame becomes small and V_f decreases to zero[10,11,16]. $u_{\infty*}$, the value of u_{∞} for $V_f=0$ depends on the configuration and material properties of the solid combustible and the composition of the ambient gas stream. The measured values of $u_{\infty*}$ for the paper sheets of δ (thickness)=0.026 and 0.05 cm were 80.2 and 81.5 cm/s, respectively.

When u_{∞} is instantaneously increased from $u_{\infty 1}$ ($u_{\infty 1} < u_{\infty*}$) for steady flame spread to $u_{\infty 2}$ ($u_{\infty 2} > u_{\infty*}$) above the critical value for flame spread, extinction of the flame which has been stably spreading occurs. As indicated in the study of Sato et al.[16], there are two modes of extinction in such a case. One is delayed extinction and the other is instantaneous extinction. The time τ from the instantaneous velocity change to extinction for delayed extinction is much longer than that for instantaneous extinction.

The variation of τ with $u_{\infty 2}$ for $u_{\infty 1}=24$ cm/s was examined and the result is shown in Fig.2. u_{∞} was instantaneously increased from $u_{\infty 1}$ to $u_{\infty 2}$ within less than 2 ms, the value of which was examined by a hot wire anemometer of 2 μ s in response time. The purpose of the present study is to explore the delayed extinction to a further extent, so that typical sets of $u_{\infty 1}$ and $u_{\infty 2}$ for delayed extinction were adopted. The value of $u_{\infty 1}$ adopted in the experiments was 24 cm/s and the values of $u_{\infty 2}$ were 90, 100, and 110 cm/s.

Transition of Gas Phase Temperature Field to Extinction

A typical series of high-speed schlieren photographs is presented in Fig.3, which represent the variation of overall temperature field near the flame in the process of delayed extinction. t represents the time after instantaneous change of u_{∞} .

Before change of u_{∞} ($t < 0$), the maximum distance d_f between the flame and pyrolysis zone surface is 2.6 mm. At $t = 15$ ms, the high temperature region near the leading flame edge is found to become narrow. At $t = 30$ ms the value of d_f become minimum to 1.2 mm. The schlieren photograph at this instant indicates that the flame following to its leading edge approaches to the solid surface. This implies that the rate of heat transfer from gas to solid increases during the period from the velocity change to this stage.

At $t = 55$ ms, d_f becomes to be 1.6 mm which is larger than that at $t = 30$ ms, and at $t = 80$ ms, it becomes smaller again. This flame fluctuation repeats at a period of 25 ms. Its amplitude decreases gradually as the flame becomes small but continues until $t = 1.7$ s when extinction of the flame occurs.

A typical series of temperature distributions measured using fine thermocouples is presented in Fig.4. The thermometric error due to the radiation loss from the heated thermocouples was corrected [17,18]. The response time of the used thermocouples was estimated to be about 10 ms. This response time is not adequate for measuring of the temperature variation to occur within 10 ms, but it is assumed sufficient for examining the overall temperature variation in a period longer than a few tens ms.

It is seen that the variation of the temperature field examined using thermocouples agrees fairly well with that examined using high speed schlieren photography. The result of the thermocouple measurement (Fig.4) shows that the highest temperature layer, which must coincide

Fig.3 A series of high-speed schlieren photographs representing the variation of overall temperature field near the flame to the delayed extinction ($u_{\infty 1} = 24$ cm/s, $u_{\infty 2} = 90$ cm/s, $\delta = 0.05$ cm) t ; time after velocity change.

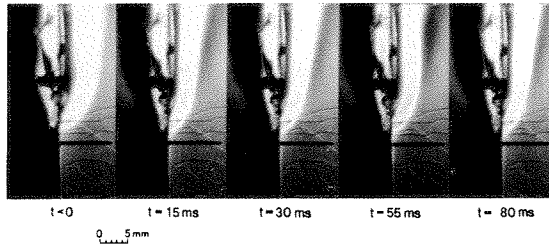
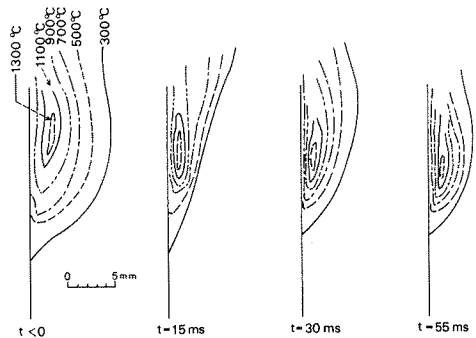

Fig.4 A series of temperature distributions near the flame to the delayed extinction ($u_{\infty 1} = 24$ cm/s, $u_{\infty 2} = 90$ cm/s, $\delta = 0.05$ cm) t ; time after velocity change.



with the layer of the highest rate of combustion reaction, gradually shifts to the upstream side. This phenomenon is inferred to be caused by consumption of pyrolyzing solid during delayed extinction[16].

In the case for $u_{\infty 2}=90$ cm/s, the measured maximum distances d_f between the highest temperature region and the solid surface at $t<0$ and $t=75$ ms were 2.6 and 1.4 mm, respectively. The ratio of the boundary layer thickness on a flat plate at $u_{\infty 1}$ to that at $u_{\infty 2}$ is given to be $(u_{\infty 1}/u_{\infty 2})^{0.5}$. In the aforementioned case, the ratio is $(24/90)^{0.5}=0.52$, which is much the same with $1.4/2.6=0.54$. This fact implies that the distance from the flame to solid surface is closely related to the boundary layer far ahead of the leading flame edge.

Behavior of Pyrolysis

Typical temperature variations examined at several points on the surface of a paper sheet in the process of delayed extinction are shown in Fig.5. The locations of thermocouples at the moment of velocity change are indicated in the figure inserted in Fig.5. The experiment was conducted under the same conditions with that of Fig.4.

It is seen from the temperature histories recorded by the thermocouples A, B, and C that the temperature on the pyrolysis zone surface is almost constant before the velocity change. In this case, the constant temperature is about 510 °C. Just after the velocity change, the temperature suddenly starts to increase at a rate of several hundreds °C/s, and reaches a maximum when t is a few hundreds ms. The maximum temperatures recorded by the thermocouples A, B, and C are several tens °C higher than those before the velocity change. Then, the temperature decreases and a temperature maximum appears at $t=2.7$ s before the temperature becomes room temperature.

The thermocouples D and E seems to be at the points on the pre-heat zone surface at the moment of velocity change. At the point for D, the temperature decreases just after the velocity change, then increases after $t=0.35$ s, passes a maximum at $t=1.2$ s, and finally decreases to be room temperature at $t=3.5$ s. The temperature variation at the point E is

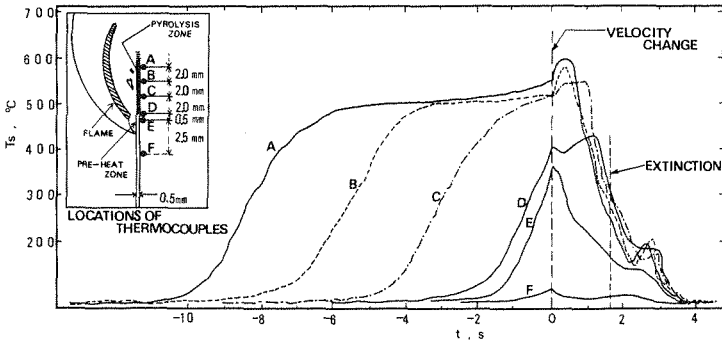

Fig.5 Temperature variations at several points on the surface of a paper sheet in the process of delayed extinction ($u_{\infty 1}=24$ cm/s, $u_{\infty 2}=90$ cm/s, $\delta=0.05$ cm).

very simple. After the velocity variation, it decreases monotonously to be zero at $t \approx 3.0$ s.

The thermocouple F was at the point far ahead of the leading flame edge at the velocity change ($t=0$). Its variation is very small. A slight temperature increase is recorded at a period near $t=0$.

The heat q'' transferred from the flame to the pyrolysis zone surface per unit time and area of one side of the paper sheet can be assumed to be equal to the half of the sum of heats needed for the endothermic pyrolysis reaction and temperature increase of the sheet. Since the paper sheet is thermally thin, the heat transfer through the inside of the sheet can be neglected [9,19]. At such a situation, the following equation must be valid.

$$q'' = \frac{1}{2} \left[\delta \rho c_p \frac{dT_s}{dt} - \delta H A_p \exp\left(-\frac{E_s}{RT_s}\right) \right] \quad (1),$$

where T_s is the temperature of the pyrolysis zone surface, c_p the specific heat at constant pressure, ρ the density of pyrolyzing paper sheet, A the pre-exponential factor, R the gas constant, E_s the activation energy of paper, and H the heat of decomposition per unit mass of paper. In the process to derive Eq.(1), the pyrolyzing rate is assumed to be proportional to ρ .

Before the velocity change, the first term of the right hand side of Eq.(1) can be neglected. Thus, the following relation is valid.

$$q''^* = \frac{1}{2} \left[-\delta H A_p^* \exp\left(-\frac{E_s}{RT_s^*}\right) \right] \quad (2),$$

where the superscript * refers to the stable flame spread.

Assuming that the mode of heat transfer from the flame to the pyrolysis zone surface is convection, q'' and q''^* can be evaluated by the following approximate relations.

$$q'' = \lambda_g ((T_f - T_s) / d_f) \quad (3)$$

and

$$q''^* = \lambda_g ((T_f - T_s^*) / d_f^*) \quad (4),$$

where T_f and λ_g represent the mean values of the thermal conductivity of the gaseous mixture and the flame temperature, respectively. Although the length and strength of flame, which affect the value of q'' and q''^* , should depend on the length of pyrolysis zone [16], its length is supposed to change little just after velocity change.

Using Eqs. (1) through (4), the following relation representing the variation of T_s with time can be derived.

$$\frac{dT_s}{dt} = \frac{AH}{c_p} \left[\exp\left(-\frac{E_s}{RT_s}\right) - \frac{\rho^* d_f^*}{\rho d_f} \left(\frac{T_f - T_s}{T_f - T_s^*}\right) \exp\left(-\frac{E_s}{RT_s^*}\right) \right] \quad (5)$$

At the moment just after the velocity change, either of $(T_f - T_s)/(T_f - T_s^*)$ and ρ^*/ρ can be assumed to be unity without loss of accuracy. In the present study, T_s^* can be evaluated from the measured temperature history as shown in Fig.5. Further, the ratio of d_f^*/d_f can be measured on the schlieren photographs or from the temperature distributions. Using measured values of T_s^* and d_f^*/d_f as initial values and other constants, i.e.,

$$\lambda_g = 6.16 \times 10^{-5} \text{ [cal/(cm}\cdot\text{s}\cdot\text{K)]},$$

$$A = 1.0 \times 10^{10} \text{ [s}^{-1}\text{]}, \quad H = 180.0 \text{ [cal/g]}, \quad T_f = 1400 \text{ [}^\circ\text{C]},$$

$$E_s/R = 1.52 \times 10^4 \text{ [K]}, \quad c_p = 3.53 \text{ [cal/(g}\cdot\text{K)]},$$

the variations of T_s just after the velocity change were calculated. The results are shown in Fig.6. It is seen that the calculated variations of T_s after the velocity change agrees fairly well with the measured ones. As $u_{\infty 2}$ is increased, the temperature increasing rate increases. This fact implies that the rapid increase of T_s is caused by the increased heat flux induced by the approach of the flame to the pyrolysis zone surface.

The increase of T_s must enhance the pyrolysis reaction and consequently the pyrolysis gas ejection velocity increases. The behavior of the flame just after the velocity change can be interpreted by considering this increase of the pyrolysis reaction rate. The appearance of the second temperature peak at the temperature history recorded by the thermocouple D implies the extension of the leading flame edge to the upstream direction. This phenomenon is attributable to the flame size increase caused by the increase of the pyrolysis gas ejection velocity.

At the final stage of the delayed extinction, the surface of residual carbon was observed to become bright yellow. Surface combustion was supposed to occur. The small temperature peaks recorded by the thermocouples A, B, and C just before the recorded temperatures became room temperature must be due to this surface combustion. The fact that the peak temperatures were low is attributable to the detachment of the thermocouples from the solid surface at this stage.

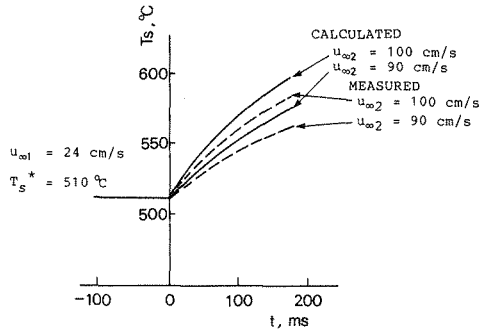

Fig.6 Calculated temperature variations on the pyrolysis zone surfaces just after velocity change ($\delta=0.05$ cm).

CONCLUDING REMARKS

The delayed extinction of the flame spreading over a paper sheet after the velocity change of an upward ambient air stream has been studied in detail using high-speed schlieren photography and fine-wire thermocouples.

Just after the velocity change, the flame approaches the pyrolysis zone surface. Consequently, the heat flux from the flame to the pyrolysis zone increases and the pyrolysis zone temperature increases. This process was confirmed in the present experimental study. The approach of the flame to the pyrolysis zone and the rapid increase of the pyrolysis zone surface temperature were shown.

Since the pyrolysis reaction is endothermic, the increase of the paper sheet temperature enhances the reaction rate and causes the increase of ejection velocity of the pyrolysis gas. The flame behavior after the velocity change can be interpreted well by considering this phenomenon. As pointed out already, the second temperature peak recorded by the thermocouple D indicates the extension of the leading flame edge to the upstream direction caused by this gas ejection velocity increase.

The knowledge obtained through the present study seems useful to increase understanding not only of delayed extinction but also of stable flame spread over solid combustibles. In the study using static flame spread apparatus, it is not so easy to examine the effect of one variable on flame spread under the conditions to keep other ones fixed. When the ambient air stream is changed in a static manner, the pyrolysis zone temperature and the gas ejection velocity must be changed at the same time. By adopting the manner used in the present study, only the air stream velocity can be changed, at least during the period just after the velocity change. The most important knowledge on this viewpoint is concerning the effect of the air stream velocity on heat and mass transfer to and from the pyrolysis zone. The variation of the pyrolysis temperature with the ambient air velocity should be taken into account in the future model of flame spread along combustible solid surface.

REFERENCES

1. Friedman, R., A: Fire Research Abstracts and Reviews, 10, 1 (1968).
2. Magee, R., S. and McAlevy III, R., F.: Journal of Fire and Flammability 2, 271 (1971).
3. Sirignano, W., A.: Combustion Science and Technology, 6, 95 (1972).
4. Williams, F., A.: Sixteenth Symposium (International) on Combustion p.1281, The Combustion Institute (1976).
5. Sibulkin, M. and Little, M.W.: Combustion and Flame, 31, 197 (1978).
6. Quintiere, J. G.: Fire and Materials, 5, 52 (1981).
7. Fernandez-Pello, A.C., Ray, S.R., and Glassman, I.: Eighteenth Symposium (International) on Combustion, p.579, The Combustion Institute (1981).

8. Fernandez-Pello,A.C.and Hirano,T.:Combustion Science and Technology, 32, 1 (1983).
9. Ito, A. and Kashiwagi, T.:Twenty-First Symposium (International) on Combustion, (to be published), The Combustion Institute (1987).
10. Hirano,T.and Sato,K.:Fifteenth Symposium (International) on Combustion, p.233, The Combustion Institute (1975).
11. Hirano,T.,Sato,K.,and Tazawa,K.:Combustion and Flame, 26, 191 (1976).
12. Frey,A.E.and T'ien,J.S.:Combustion and Flame, 26, 257 (1976).
13. Hirano,T.and Tazawa,K.:Bulletin of Japanese Association of Fire Science and Engineering, 26, 1, 7 (1976).
14. Altenkirch,R.A., Eichhorn,R.,and Shang,P.C.:Combustion and Flame, 37, 71 (1980).
15. Kodama,H.,Miyasaka,K.,and Fernandez-Pello,A.C.:Twenty-First Symposium (International) on Combustion,PS 174,The Combustion Institute (1986).
16. Sato,K.,Miki,K.,and Hirano,T.:Fire Dynamics and Heat Transfer, 25, 9 (1983).
17. Kaskan,W.E.:Sixth Symposium (International) on Combustion, p.134, The Combustion Institute (1957).
18. Fristrom,R.M.and Westenberg,A.A.:Flame Structure, McGraw-Hill, 1965, Chapter 8.
19. Fernandez-Pello,A.C.and Santro,R.J.:Seventeenth Symposium (International) on Combustion, p.1201, The Combustion Institute (1979).

