

# Soot Generation in Fires: An Important Parameter for Accurate Calculation of Heat Release

S. BROHEZ and C. DELVOSALLE  
*Faculté Polytechnique de Mons, Chem. Eng. Dep.,  
56 Rue de l'Epargne, 7000 Mons, Belgium*

G. MARLAIR  
*INERIS, Explosion and Fire Dep.,  
Parc ALATA, BP n°2, 60550 Verneuil-en Halatte, France*

A. TEWARSON  
*Factory Mutual Research Corporation,  
1151 Boston-Providence Turnpike, Norwood, MA 02062, USA*

## ABSTRACT

Oxygen consumption (OC) calorimetry and carbon dioxide generation (CDG) calorimetry are usual methods to determine the heat release rate (HRR) in bench-scale and large-scale fire tests. The paper emphasises on measuring problems associated with fires releasing large amounts of soot. Until now, the soot-related energy transfer was hardly ever taken into consideration in practical applications of HRR calculations. From standard CDG calorimetry, a generalised relationship is introduced in order to take into account the soot generation in the accurate determination of the heat release produced in sooty fires. The analysis of the significance of this correction factor is discussed by theoretical consideration as well as from results of lab-scale experiments recently carried out on chemicals by means of the INERIS fire calorimeter.

**KEYWORDS:** fire tests, heat release rate, carbon dioxide generation calorimetry, soot generation

## NOTATION LIST

- $a$  Number of carbon atoms in the test molecule  $C_aH_bO_cCl_d$   
 $C_s$  Mass concentration of smoke particles ( $g \cdot m^{-3}$ )

$E_{CO_2}$	Energy release per unit mole of CO <sub>2</sub> produced for complete combustion (kJ.mole <sup>-1</sup> )
$E'_{CO}$	Energy release per unit mole of CO produced for incomplete combustion to CO (kJ.mole <sup>-1</sup> )
$E''_S$	Energy release per unit mole of soot produced (assumed to be carbon) for incomplete combustion to soot (kJ.mole <sup>-1</sup> )
$f_i$	Yield of i (mass of i produced to mass of fuel lost)
$I_0$	Intensity of incident light
$I$	Intensity of the transmitted light through smoke
$k$	Light extinction coefficient (m <sup>-1</sup> )
$L$	Optical path length through smoke (m)
$\dot{m}$	Mass flow rate (g.s <sup>-1</sup> )
$M$	Molecular weight (g.mol <sup>-1</sup> )
$\dot{q}$	Heat Release Rate (kW)
$r$	Ratio of HRR without soot correction to the actual HRR.
$\dot{V}_e$	Volume flow rate in the exhaust duct (m <sup>3</sup> .s <sup>-1</sup> )
$x_i$	Ratio of yield of product i to yield of CO <sub>2</sub> (normalised yield of product i)
$Y_i$	Molar fraction of i
$\Delta H_{CO}$	Energy release per unit mole of CO consumed in the burning of CO (283 kJ.mole <sup>-1</sup> )
$\Delta H_S$	Energy release per unit mole of carbon consumed in the burning of carbon (393.5 kJ.mole <sup>-1</sup> )
$\sigma_S$	Specific extinction area per unit mass of soot (m <sup>2</sup> .g <sup>-1</sup> )
$\alpha$	Expansion factor (=1.105)
$\varepsilon$	Average relative variation
$\phi$	Oxygen depletion factor (see equation 7)
$\Phi$	Equivalence ratio

### Subscripts

$a$	Refers to incoming air
$e$	Refers to fumes in the exhaust duct
$f$	Refers to burning fuel
$i$	Refers to compounds

### Superscripts

$A$	Refers to molar fractions in the analyser
$A^0$	Refers to molar fractions in the analyser prior to the test
$^o$	Refers to incoming air

## INTRODUCTION

Heat release rate evaluation is a common practice in any fire risk assessment procedure. Usual methods to measure heat release rate are based on the application of the oxygen consumption (OC) [1-4] and carbon dioxide generation (CDG) calorimetry [1]. The OC calorimetry states that heat of complete combustion per unit mass of oxygen consumed is approximately constant for many carbon and hydrogen containing organic solid, liquid and gaseous compounds [4,5].

CDG calorimetry similarly states that heat of complete combustion per unit mass of carbon dioxide generated is approximately constant for most organic liquid, gaseous and solid compounds [1]. The heat of combustion per unit mass of carbon dioxide generated for a large number of gases, liquids and solids is 13.3 kJ/g with a  $\pm 11\%$  variation.

The heat release rates calculated from CDG calorimetry using average values of the heat of combustion per unit mass of carbon dioxide and carbon monoxide generated are only approximate. For accurate heat release rate calculations, actual elemental composition of the material and net heat of complete combustion are required.

In addition, high molecular weight organic compounds or halogen containing chemical substances may release large amounts of soot irrespective of the ventilation conditions. Ventilation controlled fires also provide favourable conditions for increasing yields of soot for various chemical substances. Classical CDG calorimetric relationships have thus been reviewed to derive adequate procedures capable of appraising the effect of soot production on effective heat release calculation. The assessment of the significance of the soot correction factor is examined by use of experimental data at lab-scale.

## THEORETICAL BACKGROUND OF MODERN FIRE CALORIMETRY

The OC and CDG calorimetry are extensively used both in bench-scale and large-scale fire tests [6,7,8,9,10,11]. Most of these tests are carried out in open or semi-open systems, where a hood is used above the burning item to exhaust all combustion products plus dilution air. In practice, the measurements of the gas flow rate, temperature and effluent composition (molar fractions of oxygen, carbon dioxide and carbon monoxide, essentially) allow easy calculation of the heat release rate of the experimental fire by derivation of mass balances on oxygen and/or carbon.

In the standard CDG calorimetry, the heat release rate is calculated from the measurement of the mass generation rate of CO<sub>2</sub>, corrected for the mass generation rate of CO [1] :

$$\dot{q} = \frac{E_{CO_2}}{M_{CO_2}} (\dot{m}_{CO_2} - \dot{m}_{CO_2}^0) + \frac{E'_{CO}}{M_{CO}} \dot{m}_{CO} \quad (1)$$

where

- $\dot{q}$  = Heat release rate (kW)
- $E_{CO_2}$  = Energy release per unit mole of CO<sub>2</sub> generated for complete combustion to CO<sub>2</sub> (kJ.mole<sup>-1</sup>)
- $E'_{CO}$  = Energy release per unit mole of CO generated for incomplete combustion to CO (kJ.mole<sup>-1</sup>)
- $M_{CO_2}$  = Molecular weight of carbon dioxide (44 g.mole<sup>-1</sup>)
- $M_{CO}$  = Molecular weight of carbon monoxide (28 g.mole<sup>-1</sup>)
- $\dot{m}_{CO_2}^0$  = Mass flow rate of CO<sub>2</sub> in the incoming air (g.s<sup>-1</sup>)
- $\dot{m}_{CO_2}$  = Mass flow rate of CO<sub>2</sub> in the exhaust duct (g.s<sup>-1</sup>)
- $\dot{m}_{CO}$  = Mass flow rate of CO in the exhaust duct (g.s<sup>-1</sup>)

Since the water vapour is removed from the sampling line before the measurement of molar fractions of O<sub>2</sub>, CO<sub>2</sub> and CO, the mass flow rate of CO<sub>2</sub> in the incoming air,  $\dot{m}_{CO_2}^0$ , is given by:

$$\frac{\dot{m}_{CO_2}^0}{M_{CO_2}} = \frac{\dot{m}_a}{M_a} (1 - Y_{H_2O}^0) Y_{CO_2}^0 \quad (2)$$

where

- $\dot{m}_a$  = Mass flow rate of incoming air (g.s<sup>-1</sup>)
- $M_a$  = Molar weight of incoming air (29 g.mole<sup>-1</sup>)
- $Y_{H_2O}^0$  = Molar fraction of water vapour in the incoming air
- $Y_{CO_2}^A$  = Measured<sup>1</sup> molar fraction of carbon dioxide in the incoming air

The mass flow rates of CO<sub>2</sub> and CO in the exhaust duct are given respectively by

$$\frac{\dot{m}_{CO_2}}{M_{CO_2}} = \frac{\dot{m}_e}{M_e} (1 - Y_{H_2O}) Y_{CO_2}^A \quad (3)$$

$$\frac{\dot{m}_{CO}}{M_{CO}} = \frac{\dot{m}_e}{M_e} (1 - Y_{H_2O}) Y_{CO}^A \quad (4)$$

where

- $\dot{m}_e$  = Mass flow rate in the exhaust duct (g.s<sup>-1</sup>)
- $M_e$  = Molar weight of fumes in the exhaust duct (g.mole<sup>-1</sup>)
- $Y_{H_2O}$  = Molar fraction of water vapour in the exhaust flow
- $Y_{CO_2}^A, Y_{CO}^A$  = Measured<sup>1</sup> molar fraction of CO<sub>2</sub> and CO respectively (during the combustion test)

By substituting equations (2), (3) and (4) into equation (1), the equation to calculate the heat release rate by CDG calorimetry becomes

$$\dot{q} = \frac{\dot{m}_e}{M_e} (1 - Y_{H_2O}) (E_{CO_2} Y_{CO_2}^A + E_{CO} Y_{CO}^A) - \frac{\dot{m}_a}{M_a} (1 - Y_{H_2O}^0) E_{CO_2} Y_{CO_2}^0 \quad (5)$$

Due to the large dilution factor of the combustion gases generally induced by the air entrained into the exhaust hood, it can generally be assumed that  $M_e$  is nearly equal to  $M_a$ . The same technical background hopefully justifies in most practical applications a further simplification in the effective calculation procedure by neglecting the influence of water vapour molar fractions. In many cases the error is negligible. A more detailed evaluation of the water molar fractions influence has been provided recently in another paper [13] considering the case of methane which represents a worst case because it is the hydrocarbon with the highest hydrogen to carbon ratio.

The mass flow rate of incoming air may be calculated from the following equation [12]:

$$\dot{m}_a = \frac{\dot{m}_e}{1 + \phi(\alpha - 1)} \quad (6)$$

$$\text{with, } \phi = \frac{Y_{O_2}^0 (1 - Y_{CO_2}^A - Y_{CO}^A) - Y_{O_2}^A (1 - Y_{CO_2}^0)}{(1 - Y_{O_2}^A - Y_{CO_2}^A - Y_{CO}^A) Y_{O_2}^A} \quad (7)$$

<sup>1</sup> The nomenclature is the same as that used by Janssens and Parker [12]. The superscript A refers to molar fraction of any species measured in the analyser (which is different from the corresponding molar fraction in the exhaust flow).

where,

- $\phi$  = Oxygen depletion factor
- $Y_{O_2}^{A^0}$  = Measured molar fraction of oxygen in the incoming air
- $Y_{O_2}^A$  = Measured molar fraction of oxygen during the combustion test
- $\alpha$  = Expansion factor (average value  $\approx 1,105$ )

## INTRODUCING A SOOT GENERATION CORRECTION FACTOR

The chemical nature of the burning material or specific fire conditions (e.g. underventilation) can lead to large productions of soot [1,14,15]. This statement has led us to study a modified equation allowing the calculation of heat release based on CDG to take into account the soot production:

$$\dot{q} = \frac{E_{CO_2}}{M_{CO_2}} (\dot{m}_{CO_2} - \dot{m}_{CO_2}^0) + \frac{E'_{CO}}{M_{CO}} \dot{m}_{CO} + \frac{E''_S}{M_S} \dot{m}_S \quad (8)$$

where

- $E''_S$  = Energy release per unit mole of soot generated for incomplete combustion to soot ( $\text{kJ.mole}^{-1}$ )
- $\dot{m}_S$  = Mass flow rate of soot in the exhaust duct ( $\text{g.s}^{-1}$ )
- $M_S$  = Molecular weight of soot ( $12 \text{ g.mole}^{-1}$ )

Chemical analysis shows that (mature) soot particles generated from hydrocarbons burning in diffusion flames contain only a few percents by weight of hydrogen and oxygen [16,17]. It can thus be assumed that soot particles are principally made of carbon.

Since condensable species and soot particles are removed from the sampling line before measurement of molar fractions of  $O_2$ ,  $CO_2$  and  $CO$ , the mass flow rates of carbon dioxide and carbon monoxide in the exhaust duct are given by:

$$\frac{\dot{m}_{CO_2}}{M_{CO_2}} = \frac{\dot{m}_e}{M_e} Y_{CO_2}^A (1 - \sum_n Y_{cond,n} - Y_S) \quad (9)$$

$$\frac{\dot{m}_{CO}}{M_{CO}} = \frac{\dot{m}_e}{M_e} Y_{CO}^A (1 - \sum_n Y_{cond,n} - Y_S) \quad (10)$$

where

- $Y_{cond,n}$  = Molar fractions of condensable species such as  $H_2O$ , acid gases ( $HCl, \dots$ ) in the exhaust duct
- $Y_S$  = Molar fraction of soot in the exhaust duct

The mass flow rate of soot can be measured by direct sampling or calculated from optical smoke measurements. According to Lambert-Beer law, the attenuation of monochromatic light over a given optical path through the smoke generated by the burning fuel can be expressed as

$$\frac{I}{I_0} = e^{-k.L} \quad (11)$$

where

- $I_0$  = intensity of incident light
- $I$  = intensity of the transmitted light through smoke
- $L$  = optical path length through smoke (m)
- $k$  = light extinction coefficient ( $m^{-1}$ )

It has been shown that light extinction coefficient  $k$  is proportional to mass concentration of soot particles [18,19]:

$$k = \sigma_S C_S \quad (12)$$

where,

- $C_S$  = Mass concentration of smoke particles ( $g.m^{-3}$ )
- $\sigma_S$  = Specific extinction area per unit mass of soot ( $m^2.g^{-1}$ )

The value of the specific extinction area  $\sigma_S$  is roughly constant for fuels burning in flaming mode and producing primarily carbon soot [20]. In open systems, since the attenuation of light through smoke is measured in the exhaust duct, the mass flow rate of soot follows as:

$$\dot{m}_S = C_S \dot{V}_e = \frac{k \dot{V}_e}{\sigma_S} \quad (13)$$

where

- $\dot{V}_e$  = Volume flow rate in the exhaust duct at the actual temperature where the photometer is located ( $m^3.s^{-1}$ )

The molar fraction of soot in the exhaust duct can be written as

$$Y_S = \frac{\dot{m}_S}{\dot{m}_e} \frac{M_e}{M_S} \quad (14)$$

Finally, the heat release rate taking account of the soot generation is given by:

$$\dot{q} = \frac{\dot{m}_e}{M_e} (1 - \sum_n Y_{cond,n} - Y_S) (E_{CO_2} Y_{CO_2}^A + E'_{CO} Y_{CO}^A) - \frac{\dot{m}_a}{M_a} (1 - Y_{H_2O}^0) E_{CO_2} Y_{CO_2}^0 + \frac{E'_S k \dot{V}_e}{M_S \sigma_S} \quad (15)$$

For a practical application of equation (15), the user still requires the values of the calorimetric coefficients  $E_{CO_2}$ ,  $E'_{CO}$  and  $E'_S$ . With some exceptions, the value of  $E_{CO_2}$  is approximately constant [1]. Tewarson calculated the calorimetric coefficient  $E_{CO_2}$  for a list of about 200 compounds. From these actual values, the average value of the calorimetric coefficient  $E_{CO_2}$  is 585,2 kJ per mole with an average variation  $\varepsilon_{CO_2}$  of 8,5%<sup>2</sup>.

<sup>2</sup> Average variation calculated from actual values of  $E_{CO_2}$

By application of the Hess law, the calorimetric coefficients  $E'_{CO}$  and  $E''_S$  may be calculated from

$$E'_{CO} = E_{CO_2} - \Delta H_{CO} = 302,2 \frac{kJ}{mole} \quad (16)$$

$$E''_S = E_{CO_2} - \Delta H_S = 191,7 \frac{kJ}{mole} \quad (17)$$

where

$\Delta H_{CO}$  = Energy release by complete combustion of CO per unit mole of CO consumed (283 kJ.mole<sup>-1</sup>)

$\Delta H_S$  = Energy release by complete combustion of soot (assumed to be C) per unit mole of carbon consumed (393.5 kJ.mole<sup>-1</sup>)

From equations (16) and (17), it comes out that the calorimetric coefficients  $E_{CO_2}$ ,  $E'_{CO}$  and  $E''_S$  have the same average absolute variation of 49,7 kJ/mole. The average relative variations of  $E'_{CO}$  and  $E''_S$  may be calculated from:

$$\varepsilon_{CO} = \varepsilon_{CO_2} \frac{E_{CO_2}}{E'_{CO}} = 16,5 \% \quad (18)$$

$$\varepsilon_S = \varepsilon_{CO_2} \frac{E_{CO_2}}{E''_S} = 25,9 \% \quad (19)$$

The average calorimetric coefficients may be useful especially for materials of unknown molecular compositions. Unfortunately, the values of the average relative variations are important. Therefore, if the actual values of the calorimetric coefficients are available for the burning material, these values should be used in the calculations instead of the approximate values.

## SIGNIFICANCE OF THE SOOT GENERATION CORRECTION FACTOR ON HRR

The heat release rate may be expressed as function of yields of CO<sub>2</sub>, CO and soot. In practice, by use of the definition of yield of product i,

$$f_i = \frac{\dot{m}_i - \dot{m}_i^0}{\dot{m}_f} \quad (20)$$

and according to equations (8) and (1), the heat release rate with or without soot correction is given respectively by

$$\dot{q}_{corrected} = \dot{m}_f \left( \frac{f_{CO_2}}{M_{CO_2}} E_{CO_2} + \frac{f_{CO}}{M_{CO}} E'_{CO} + \frac{f_S}{M_S} E''_S \right) \quad (8_{bis})$$

$$\dot{q}_{standard} = \dot{m}_f \left( \frac{f_{CO_2}}{M_{CO_2}} E_{CO_2} + \frac{f_{CO}}{M_{CO}} E'_{CO} \right) \quad (1_{bis})$$

where,

$f_i$  = Yield of  $i$  (mass of  $i$  produced to mass of fuel lost)  
 $\dot{m}_f$  = Mass loss rate of fuel ( $\text{g.s}^{-1}$ )

To assess the significance of the soot correction factor appearing in equation (15), the ratio  $r$  of the standard heat release rate (equation 1<sub>bis</sub>) to the corrected heat release rate (equation 8<sub>bis</sub>) was introduced and expressed in terms of measurable parameters according to the following procedure:

$$r = \frac{\dot{q}_{s\text{ standard}}}{\dot{q}_{\text{corrected}}} = \frac{f_{CO_2} \frac{E_{CO_2}}{M_{CO_2}} + f_{CO} \frac{E'_{CO}}{M_{CO}}}{f_{CO_2} \frac{E_{CO_2}}{M_{CO_2}} + f_{CO} \frac{E'_{CO}}{M_{CO}} + f_S \frac{E''_S}{M_S}} \quad (21)$$

Equation (21) may be normalised in the form of

$$r = \text{function} \left( x_S = \frac{f_S}{f_{CO_2}}, x_{CO} = \frac{f_{CO}}{f_{CO_2}} \right) = \frac{\frac{E_{CO_2}}{M_{CO_2}} + x_{CO} \frac{E'_{CO}}{M_{CO}}}{\frac{E_{CO_2}}{M_{CO_2}} + x_{CO} \frac{E'_{CO}}{M_{CO}} + x_S \frac{E''_S}{M_S}} \quad (22)$$

Several researchers [1,14,21,22] published experimental results about yields of soot and carbon dioxide. Some of the higher values of  $x_S$  are listed in table 1. According to the review of their experimental data, the value of 0.4 seems to be a reasonable upper limit of this variable (for common products).

**TABLE 1:** Some of the higher values of ratio of soot to carbon dioxide yields.

Substance	$x_S = \frac{f_S}{f_{CO_2}}$
Benzene	0.08
Polyvinylchloride ( $\Phi < 0.35$ ) <sup>3</sup>	0.37
Polystyrene ( $\Phi = 0.2$ )	0.07
Polystyrene ( $\Phi = 2$ )	0.19
Polystyrene ( $\Phi = 3$ )	0.32

To analyse the contribution factor of soot production, the ratio  $r$  has been plotted as a function of  $x_S$ , with two extreme values [6] of the parameter  $x_{CO}$  (see figure 1). The error by ignoring the soot correction in the heat release rate calculation may be clearly significant if the variable  $x_S$  takes a large value. As an example, for a 0.3 value of the parameter  $x_S$ , the heat release rate would be underestimated of about 25 percent if the soot correction is neglected.

<sup>3</sup>  $\Phi$  = equivalence ratio (parameter which characterises the degree of ventilation of the fire)

$$\Phi = \frac{\text{mass fuel to air ratio}}{\text{stoichiometric mass fuel to air ratio}}$$



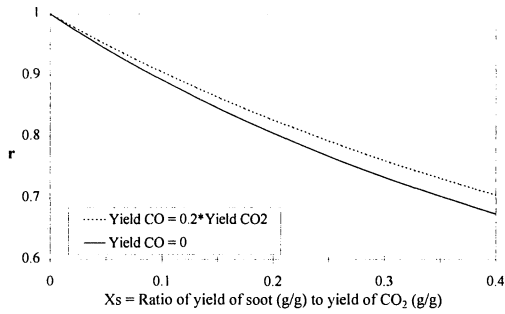

**FIGURE 1:** Influence of soot generation on the HRR calculation by CDG calorimetry

## EXPERIMENTAL RESULTS

### Compounds

To provide a further analysis on the influence of soot production on heat release calculation in fires, different chemicals were selected for small-scale experiments, according to their varying sooting tendency. The substances studied in the experiments are isooctane, cyclohexane, benzene, toluene, 1-2-4-trimethylbenzene, chlorobenzene and 1-2-dichlorobenzene. The mass of the substances burned in the experiments ranged from 25 to 70 g.

### Apparatus

The experiments were performed in the INERIS bench scale calorimeter (figure 2).

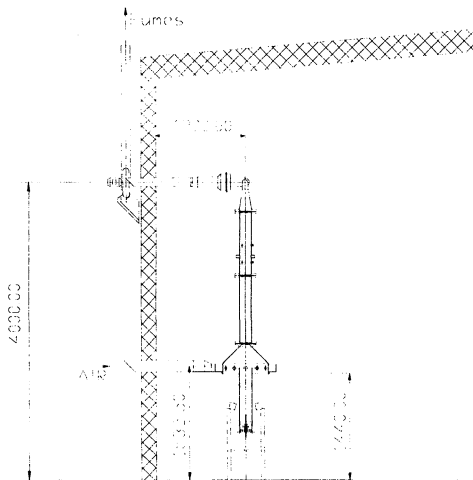

**FIGURE 2:** The INERIS bench-scale calorimeter.

As can be seen in figure 2, the INERIS calorimeter is fitted with a gas-tight air dilution system at the level of the collection hood of the fire gases to allow safe use of the apparatus on toxic chemical samples [23].

In all the experiments, a cylindrical sample holder made of glass with a diameter of 88 mm was used. The infra-red heaters were usually not used in the experiments. However, for chlorobenzene and trimethylbenzene an incident heat flux of 20 kW/m<sup>2</sup> was applied until ignition. For dichlorobenzene, an incident heat flux of 10 kW/m<sup>2</sup> had to be maintained during all test procedure to ensure flaming combustion.

For the measurement of total unburned hydrocarbons concentration (THC), a heated line (180°C) was used to draw fumes sample (through heated filter, 180°C) to the analyser (flame ionisation detector). This analyser was calibrated with the studied material by evaporating a substance sample. The mass flow rate of air at the bottom of the quartz tube was fixed at 0.2 nm<sup>3</sup>/min. For all experiments, this mass flow rate led to well-ventilated fire conditions. The mass flow rate of fumes in the exhaust duct was regulated to a constant value of 80 nm<sup>3</sup>/h.

## Results

From the measured data, the yields of carbon dioxide, carbon monoxide and unburned hydrocarbons were calculated. The results (which are averages of three tests for each substance) are given in table 2. Because measurements by direct sampling of soot or use of optical properties were not still implemented, the yield of soot was calculated from the mass balance of carbon:

$$\frac{f_{CO_2}}{M_{CO_2}} + \frac{f_{CO}}{M_{CO}} + \frac{f_{THC} a}{M_{fuel}} + \frac{f_S}{M_S} = \frac{a}{M_{fuel}} \quad (23)$$

where,

$a$  = Number of carbon atoms in the test molecule  $C_aH_bO_cCl_d$

$M_{fuel}$  = Molecular weight of the burning material (g.mole<sup>-1</sup>)

The parameters  $x_S$ ,  $x_{CO}$  and  $r$  were determined<sup>4</sup> from the yields values  $f_i$  (see table 2).

**TABLE 2:** Yields of combustion products and significance of the proposed soot correction

Substances	$f_{CO_2}$ (g/g)	$f_{CO}$ (g/g)	$f_{THC}$ (g/g)	$f_S$ (g/g)	$x_{CO}$	$x_S$	$r$ (%)
Isooctane	3.00	0.017	0.0017	0.025	0.006	0.0083	98.9
Cyclohexane	2.98	0.008	0.0003	0.04	0.003	0.013	98.3
Benzene	2.51	0.056	0.037	0.18	0.022	0.072	94.0
Toluene	2.56	0.071	0.057	0.13	0.028	0.051	95.8
1,2,4 Trimethylbenzene	2.25	0.062	0.055	0.21	0.027	0.093	92.3
Chlorobenzene	0.97	0.09	0.26	0.165	0.093	0.17	88.8
1,2 Dichlorobenzene	0.62	0.11	0.35	0.097	0.18	0.15	91.9

<sup>4</sup> Calculations made with the actual calorimetric coefficients

As can be seen in table 2, the soot correction in the heat release rate calculation is negligible for materials such as alkanes. However, this correction may become important for arenes and substituted arenes even in well-ventilated fire conditions. As an example, for chlorobenzene, the heat release rate would be underestimated by about 11% if the soot correction is neglected.

## CONCLUSION

Heat release rate in fires is one of the major parameter for fire safety engineering. Standard CDG calorimetry making use of CO<sub>2</sub> and CO measurements has been reviewed.

It has been studied whether sooting tendency of materials might be an important consideration for accurate calculations of heat release rate. A correction accounting for soot production on heat release rate calculation by CDG calorimetry has been proposed. The importance of this correction factor depends on both the chemical nature of the material being burned and the degree of ventilation of the fire.

A calorimetric coefficient  $E''_s$  corresponding to soot generation has been introduced and calculated. An average value of 191.7 kJ per mole of carbon generated is proposed with an average variation of 25.9 %. Due to the importance of this variation, the actual value of the calorimetric coefficient should be used in the calculations instead of the approximate value.

Similar considerations on soot related energy transfer on OC calorimetry is being studied and will be discussed in a forthcoming publication.

## ACKNOWLEDGEMENT

Part of this work was financially supported by:

- *La Communauté française de Belgique (Belgium)*

- *Le Ministère de l'Aménagement du Territoire et de l'Environnement (France)*

## REFERENCES

1. Tewarson A., "Generation of Heat and Chemical Compounds in Fires", in SFPE Handbook of Fire Protection Engineering, Section 3, Chapter 4, pp. 3-53 to 3-124. The National Fire Protection Association Press, Quincy, MA (1995)
2. Parker W.J., "An Investigation of the Fire Environment in the ASTM E84 Tunnel Test", National Bureau of Standards, Technical Note N° 945, Washington (1977)
3. Hinkley P.L., Wraight H.G.H. and Wadley A., "Rates of heat Output and Heat Transfer in the Fire Propagation Test", Fire Research Note N° 709, Fire Research Station, Borehamwood, England (1968)
4. Huggett C., "Estimation of the Rate of Heat Release by Means of Oxygen Consumption", Fire and Materials, 4, pp.61-65 (1980)
5. Thornton W., "The Relation of Oxygen to the Heat of Combustion of Organic Compounds",

Philosophical Magazine and J. of Science, 33, pp.196-203 (1917)

6. Janssens M.L., "Calorimetry", in SFPE Handbook of Fire Protection Engineering, Section 3, Chapter 2, pp.3-16 to 3-36, The National Fire Protection Association Press, Quincy (1995)
7. Peacock R.D., Babrauskas V., "Analysis of Large-scale Fire Test Data", Fire Safety Journal, 17, pp. 387-414 (1991)
8. Tewarson A., "Flammability Parameters of Materials: Ignition, Combustion and Fire Propagation", Journal of Fire Sciences, 12, pp. 329-356 (1994)
9. Marlair G., "Modélisation Incendie Simulant les Transferts et les Risques A L'environnement", Env. Project MISTRAL 2, Contract n°EV5V-CT94-0527 (European Commission Environment and Climate Program), Final Report, Appendix IV (1996)
10. Marlair G., Cwiklinski C., Marliere F., Costa C. and Breulet H., "A Review of Large-Scale Fire Testing Focusing on the Fire Behaviour of Chemicals", Proceedings of the Seventh International Fire Science and Engineering Conference (Interflam 96), pp. 371-382, Mars 1996
11. Marlair G., Marliere F., Costa C., Desmet S., Leck M. and Siegfried W., "Experimental Evaluation of the Fire Hazard of Organophosphorous Insecticides by Use of Various Test Methods", Proceedings of "Industrial Fires III Workshop", Roskilde (Denmark), EUR 17477 EN, pp. 93-110 (Sept. 1996)
12. Janssens M.L. and Parker W.J., "Oxygen Consumption Calorimetry", in Heat Release in Fires edited by V.Babrauskas and S.J. Grayson, Chapter 3, pp.31-59 (1992)
13. Brohez S., Delvosalle C., Marlair G. and Tewarson A., "Accurate Calculations of Heat Release in Fires", Proceedings of the 13<sup>th</sup> International Congress of Chemical and Process Engineering (2<sup>nd</sup> Symposium on Environmental and Safety Engineering, CHISA 98), paper n° 1363, 12 pages (August 1998)
14. Hietaniemi J., Kallonen R. and Mikkola E., "Fires at Chemical Warehouses, A Cone Calorimeter Study on the Burning Characteristics and Fire Effluent Composition of Selected Chemical Compounds", VTT Research Note n°1810, 56 p. + app. 35p., May 1997
15. Anderson B., Holmstedt G., Särdaqvist S., Winter G., "Simulated Fires in Substances of Pesticide Type", Proceedings of "Industrial Fires III Workshop", Roskilde (Denmark), EUR 17477 EN, pp. 17-27 (Sept. 1996)
16. Palmer H.B., Cullis C.F., "The formation of carbon from gases", in Chemistry and Physics of Carbon, edited by P.L. Walker, Vol. 1, Chapter 5, pp. 265-325 (1965)
17. Gaydon A.G., Wolfhard H.G., "Solid Carbon in Flames", in Flames, their Structures, Radiation and Temperature, 4<sup>th</sup> edition, Chapter XIII, pp. 195-237 (1979)
18. Foster W.W., "Attenuation of Light by Wood Smoke", British Journal of Applied Physics, 10, pp. 416-420 (Sept. 1959)
19. Seader J.D., Ou S.S., "Correlation of the Smoke Tendency of Materials", Fire Research, 1, pp.3-9 (1977)
20. Mulholland G.W., Henzel V. and Babrauskas V., "The effect of Scale on Smoke Emission ", Fire Safety Science - Proceedings of the Second International Symposium, pp. 347-357, 1988
21. Mulholland G.W., "Smoke Production and Properties", in SFPE Handbook of Fire Protection Engineering, Section 2, Chapter 15, pp. 2-215 to 2-227. The National Fire Protection Association Press, Quincy, MA (1995)
22. Tewarson A., "Combustion of Halogenated Polymers", Fire Safety Science - Proceedings of the Fourth International Symposium, pp. 563-574, 1994
23. Marlair G., Costa C., Gautier B., Ledoux H. and Brohez S., "On-going Experimental Fire Research and Testing in France Using Tests Rigs Derived from the "Tewarson" Apparatus", Fire Safety Sciences – Sixth International Symposium, Poitiers, France, (July 1999)